

ROTOMECH

Operator's Manual

CYCLONE SUPER-FLEX

Tri-wing Grooming Mower
Series 360, 450, 510 & 600

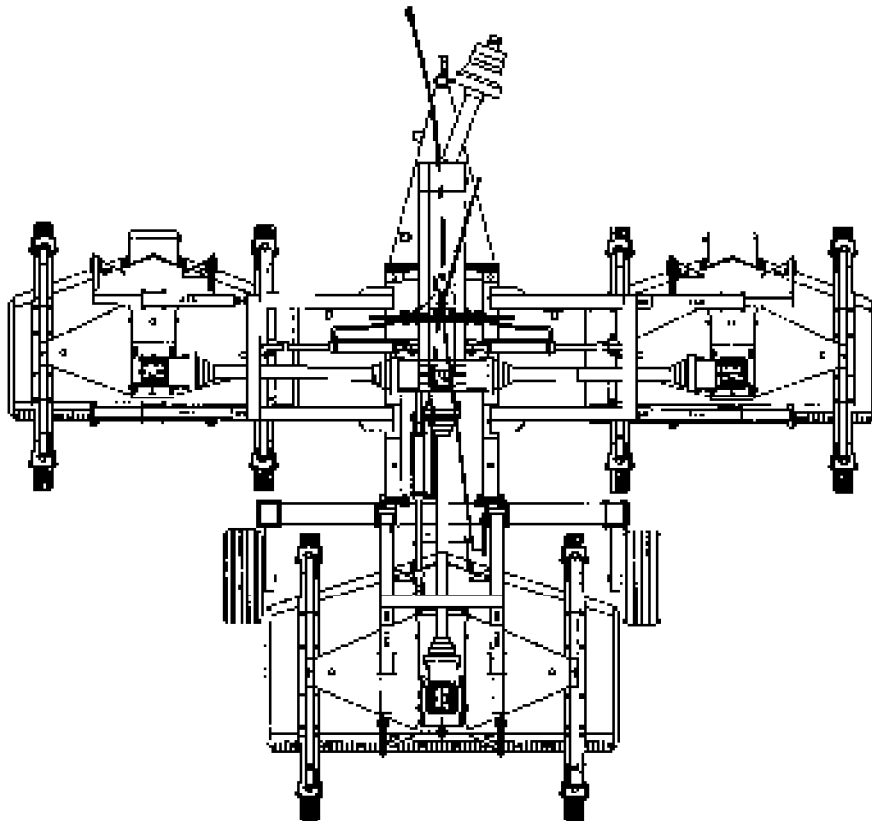

The operator's manual is a technical service guide and must always accompany the machine.

MESFLEA

SAFETY

Take note! This safety alert symbol found throughout this manual is used to call your attention to instructions involving your personal safety and the safety of others. Failure to follow these instructions can result in injury or death.



This symbol means:
ATTENTION!
BECOME ALERT!
YOUR SAFETY IS INVOLVED!

Signal Words

Note the use of the signal words DANGER, WARNING and CAUTION with the safety messages. The appropriate signal words for each has been selected using the following guidelines:



DANGER: indicates an imminently hazardous situation that, if not avoided, will result in death or serious injury.



WARNING: indicates a potentially hazardous situation that, if not avoided, could result in death or serious injury, and includes hazards that are exposed when guards are removed. It may also be used to alert against unsafe practices.

SAFETY



CAUTION: indicates a potentially hazardous situation that, if not avoided, may result in minor or moderate injury.

ROTOMECH

Operator's Manual

CYCLONE SUPER-FLEX

Tri-wing Grooming Mower
Series 360, 450, 510 & 600

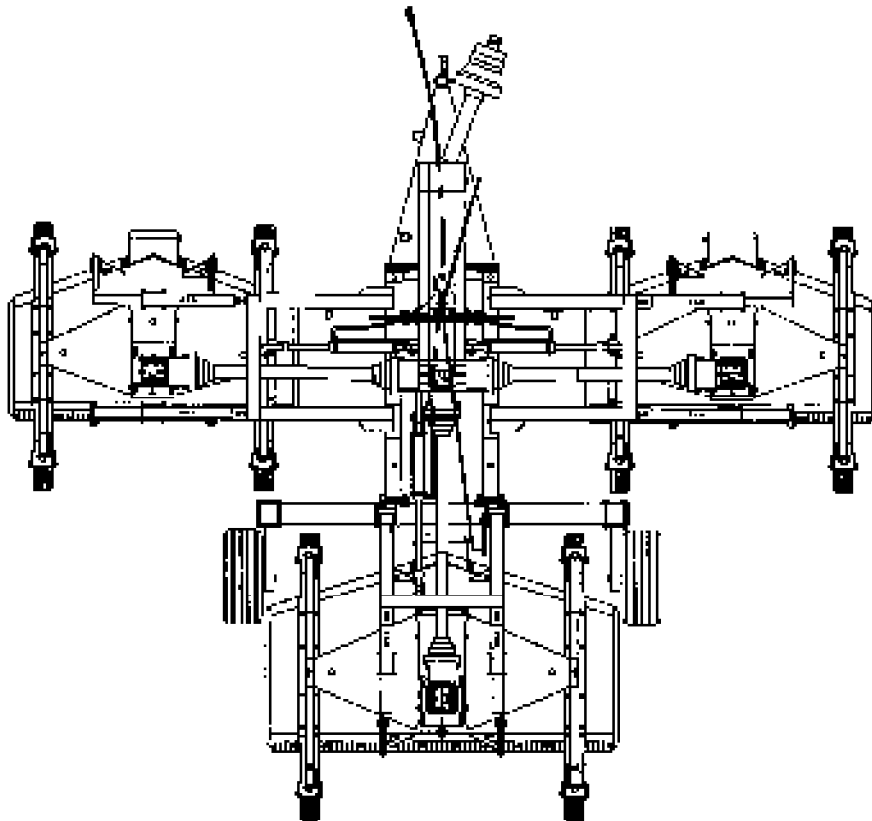

The operator's manual is a technical service guide and must always accompany the machine.

INDEX

1 - GENERAL INFORMATION	6
1.01 - General	6
1.02 - Model and Serial Number ID	6
2 - SAFETY PRECAUTIONS	8
2.01 - Preparation	8
2.02 - Starting and Stopping	9
2.03 - Messages and Signs	9
3 - OPERATION	11
3.01 - Operational Safety	11
3.02 - Set-up & Assembly Instructions	13
3.03 - Cutting Height Adjustment	15
3.04 - Pre-Operational Check	16
3.05 - Attaching to the Tractor	16
3.06 - Constant Velocity Driveline	18
3.07 - Hydraulic Lift System	19
3.08 - Frame Adjustments	19
3.09 - Start Up	24
3.10 - Working Speed	25
3.11 - Operating Techniques	26
3.12 - Uneven Terrain	28
4 - MAINTENANCE	30
4.01 - Maintenance Safety	30
4.02 - Service	31
4.03 - Blade Maintenance	34
4.04 - Belt Tension	36
4.05 - Belt Replacement	37
4.06 - Drivelines and Centre Gearbox Timing	38
4.07 - Transport	39
4.08 - Storage	40
5 - REPAIR PROCEDURES	41
5.01 - Gearbox	41
5.02 - Blade Spindle	41
5.03 - Suggested Spare Parts	42
6 - TROUBLESHOOTING	43
7 - PRE-DELIVERY CHECKLIST	44
8 - WARRANTY	46

1 - GENERAL INFORMATION

You have purchased the ideal machine for turf grass growers, golf courses, parks, school complexes, large recreational areas, airports and military installations. The Super-Flex features sizes of 3,60 m. (12'), 4,50 m. (15'), 5,10 m. (17') and 6,00 m. (20') cutting widths.

All units are constructed of high quality components and engineered for strength in professional use. Each model features 3 free floating decks with 4 wheels on each deck allowing for precise mowing over unlevel terrain. High ground speed capability and very low maintenance makes the Cyclone Super-Flex the right choice for your large acreage mowing needs.

Read this manual carefully. It will instruct you on how to operate and service your mower safely and correctly. Failure to do so could result in personal injury and/or equipment damage.

1.01 - General





CAUTION: all hardware is metric. Only metric tools should be used. Other tools that do not fit properly can slip and cause injury.

Right hand and left hand sides of the implement are determined by facing in the direction the implement will travel when going forward (see fig. 2).

1.02 - Model and Serial Number ID

Attached to the frame is a ID plate showing the model and the serial number. Record your implement model and serial number in the space provided below. Your dealer needs this information to give you prompt, efficient service when you order parts.

 ROTOMECC S.p.A. 37054 NOGARA (VERONA) ITALY PH.: 39.(0).442.510400 r.a.		
KW.	KG.	YEAR

Carefully read the warranty section¹ detailing coverage and limitations of this warranty. **Warranty** is provided for customers who operate and maintain their equipment as described in this manual. Warranty registration is accomplished by the dealer completing and forwarding the **Warranty Registration Form** to the Company, along with a copy of the dealer's invoice. It is in your best interest to insure that this has been done.

Warranty does not cover the following:

1. cleaning, transporting, mailing and service call charges.
2. Normal wear items such as belts, blades, bearings, drivelines, shear pins, slip clutches etc.
3. Depreciation or damage caused by normal wear, accidents, improper maintenance, improper protection or improper use.
4. The use of non original spare parts and accessories.

Your Authorised Dealer has genuine parts in stock. Only these approved replacement parts should be used. This limited warranty covers defective material and workmanship. The cost of normal maintenance or repairs for accidents or improper use and related labour will be borne by the owner.

¹ See chapter 8 - Warranty.

2 - SAFETY PRECAUTIONS

Safety is the primary concern in the design and manufacture of our products. Unfortunately our efforts to provide safe equipment can be wiped out by a single careless act of an operator.

In addition to the design and configuration of equipment, hazard control and accident prevention are dependent upon the awareness, concern, prudence and proper training of personnel involved in the operation, transport, maintenance and storage of equipment.

It is the operator's responsibility to read and understand all safety and operating instructions in the manual and to follow these.

Allow only properly trained personnel to operate the mower. Working with unfamiliar equipment can lead to careless injuries. Read this manual, and the manual for your tractor, before assembly or operating, to acquaint yourself with the machines. It is the mower owner's responsibility, if this machine is used by any person other than yourself, is loaned or rented, to make certain that the operator, prior to operating, reads and understands the operator's manuals and is instructed in safe and proper use.

2.01 - Preparation



1. Before operating equipment read and understand the operator's manual and the safety signs (see fig. 2).
2. Thoroughly inspect the implement before initial operation to assure that all packaging materials, i.e. wires, bands, and tape have been removed.
3. Personal protection equipment including hard hat, safety glasses, safety shoes, and gloves are recommended during assembly, installation, operation, adjustment, maintaining and/or repairing the implement.
4. Operate the mower only with a tractor equipped with an approved Roll-Over-Protective-System (ROPS). Always wear your seat belt. Serious injury or even death could result from falling off the tractor.
5. Clear area to be cut of stones, branches or other debris that might be thrown, causing injury or damage.
6. Operate only in daylight or good artificial light.
7. Ensure mower is properly mounted, adjusted and in good operating condition.
8. Ensure that all safety shielding and safety signs are properly installed and in good condition.

2.02 - Starting and Stopping



1. Be sure that no one is near the machine prior to engaging or while the machine is working.
2. Be sure the tractor is in %Neutral+before starting engine.
3. Mower operating power is supplied from tractor PTO. Refer to your tractor manual for PTO engagement and disengagement instructions. Always operate PTO at 540 rpm. Know how to stop the tractor and mower quickly in case of an emergency.
4. When engaging PTO, the engine rpm should always be low. Once engaged and ready to start cutting, raise PTO speed to 540 rpm and maintain throughout cutting operation.
5. Check the tractor master shield over the PTO stub shaft. Make sure it is in good condition and fastened securely to the tractor. Purchase a new shield if old shield is damaged or missing.
6. After striking an obstacle, disengage the PTO, shut the tractor down and thoroughly inspect for damage before restarting.
7. Never engage the PTO until all three mowers are in the down position and resting on the ground. Never raise the mowers until all blades have come to a complete stop.

2.03 - Messages and Signs



1. Read and adhere to all safety and operating decals on this machine (**see fig. 2**).
2. Before dismounting tractor: allow moving parts to stop, stop engine, set brake and remove the key of unattended equipment.
3. Keep away from rotating blades and drivelines.
4. Keep guards and shields in place and in good condition.
5. Do not mow with bystanders in area.
6. Allow no riders on tractor or mower.
7. Allow moving parts to stop before repair.
8. Securely support mower before working underneath.
9. Lock up raised wings before transport (**see fig. 11**).

Additional warning and operating decals are available at no extra charge. Please specify model and serial number when ordering.

Fig. 2 - Safety decals; replace immediately if damaged.

1. read this manual carefully
2. before maintenance operations, disengage PTO and shut tractor down
3. 540 rpm PTO only
4. keep away from rotating driveline
5. keep away, thrown objects
6. never allow passengers
7. keep away from rotating blades
8. keep away from rotating belts
9. keep away from raised mowers

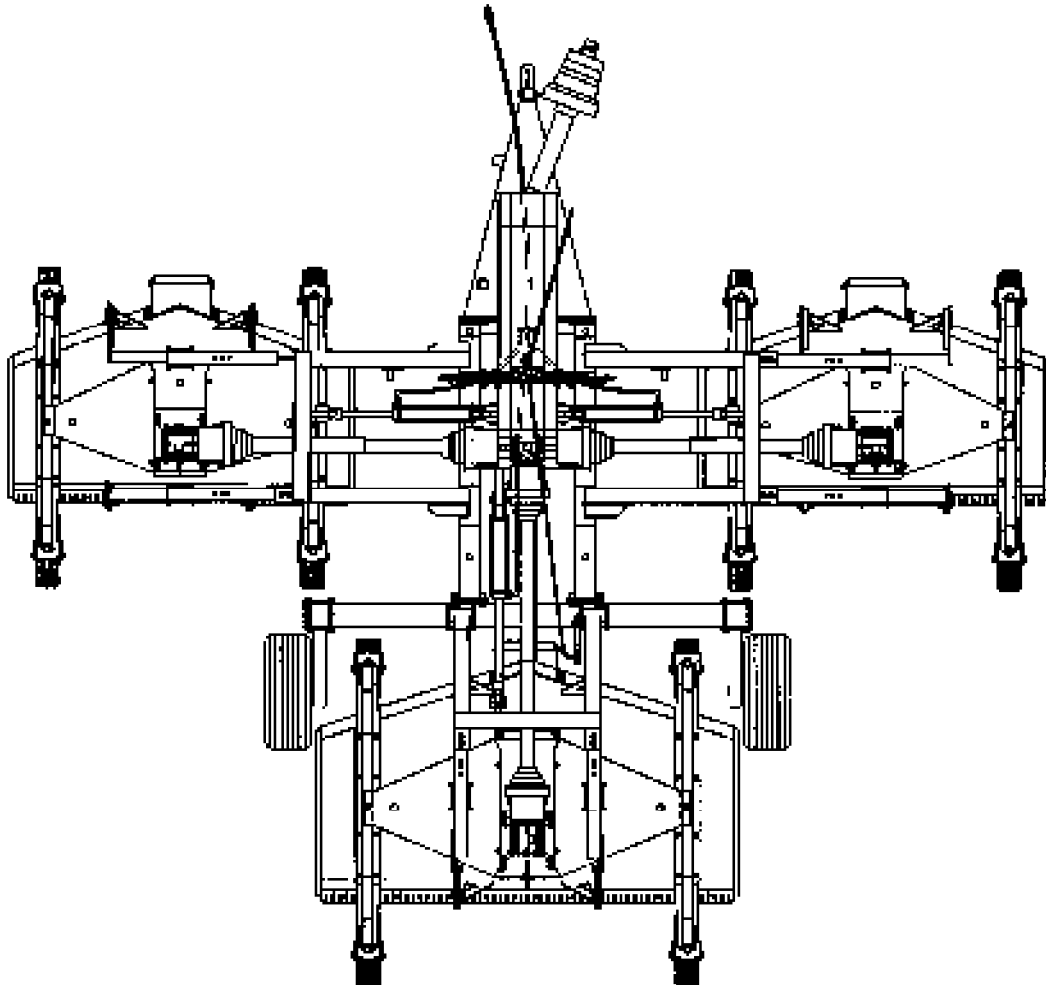
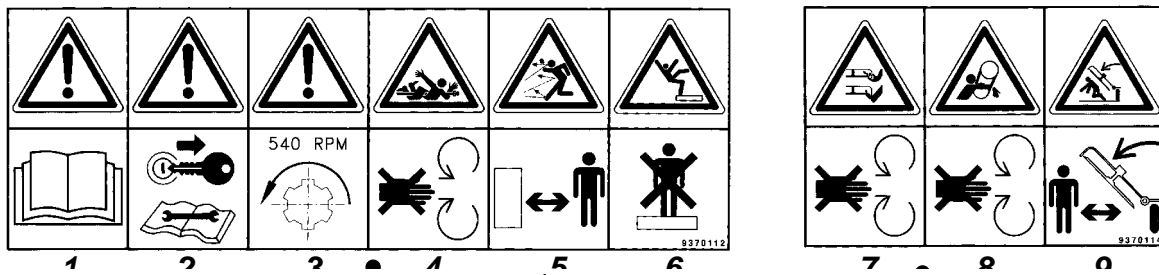

3 - OPERATION

The Cyclone Super-Flex represents the most advanced proposal for reducing labour cost without sacrificing quality of cut. The high cutting speed of 13-16 kph (8-10 mph) along with the wide working widths of up to 6 meters (20'), allows for a reduction in man-hours and lower fuel cost for the maintenance of large grass areas such as sport fields, parks, golf courses and sod farms.

The Cyclone Super-Flex consists of a frame-carrier, mechanically connecting a trio of C50 rear discharge grooming mowers. The Cyclone Super-Flex can be used on tractors with horsepower ranging from 25 to 80. The tractor PTO is connected, through a wide angle driveline with slip clutch to a transmission support transferring power through a Pto shaft to a 4 way splitter gearbox; the side and rear output shafts transfer power to the individual speed multiplier gearboxes on each mower.

The 3,60 m. (12') model consists of two 1,20 m. (4') C50 wing units and one 1,50 m. (5') C50 rear unit, the 4,50 m. (15') model consists of two 1,50 m. (5') C50 wing units and one 1,80 m. (6') C50 rear unit, the 5,10 m. (17') model uses three 1,80 m. (6') C50 decks and the 6,00 m. (20') model consists of two 2,10 m. (7') C50 wing units and one 2,10 m. (7') C50 rear unit.

Each individual mower works completely independent from the others. They are connected to the frame by floating arms. All mowers have four wheels allowing free floating over uneven terrain. Even over rolling ground, the cut is accurate and uniform. After mowing, during transport and for storage or maintenance, all three mowers can be raised up hydraulically to a vertical position. During transport or maintenance operations, it is imperative to be sure the wing mowers are locked in place with the automatic locking system. To transport over extended distances, the wings should be locked in their 90 degree vertical position with the transport locks and the metal transport braces added to the two wing units for added safety. The two transport wheels allow the Super-Flex mower, in its closed and locked position, to be transported safely on lawns or private roads. The tires are not suitable for extended road travel. The decks can be raised for easy cleaning and quick blade changes. Top grease fittings make the greasing of hubs and spindles simple and quick.

3.01 - Operational Safety



CAUTION: our mowers are designed considering safety as the most important aspect and are the safest available in today's market. Unfortunately, human carelessness can override the safety features built into our machines. Injury prevention and work safety, aside from the features on our mowers, is very much

due to the responsible use of the equipment. It must always be operated prudently following with great care, the safety instructions laid out in this manual.

1. The use of this equipment is subject to certain hazards which cannot be prevented by mechanical means or product design. All operators of this equipment must read and understand this entire manual, paying particular attention to safety and operating instructions, prior to using.
2. Do not operate the tractor and mower when you are tired, sick or when using medication.
3. Keep all helpers and bystanders at least several meters from a rotary mower. Only properly trained people should operate this machine.
4. When this machine is operated in populated areas where thrown objects could injure persons or property, standard equipment safety chain shielding (which is designed to reduce the possibility of thrown objects) must be installed.
5. The majority of accidents involve entanglements on the driveline, injury of bystanders by objects thrown by the rotating blades, and operators being knocked off the tractor by low hanging limbs and then being run over by the mower. Accidents are most likely to occur with machines that are loaned or rented to someone who has not read the operator's manual and is not familiar with a rotary mower.
6. Always stop the tractor, set brake, shut off the tractor engine, remove the ignition key, lower implement to the ground and allow mower blades to come to a complete stop before dismounting tractor. Never leave equipment unattended with the tractor running.
7. Never place hands or feet under mower with tractor engine running or before you are sure all motion has stopped. Stay clear of all moving parts.
8. Do not reach or place yourself under equipment until it is blocked securely.
9. Do not allow riders on the mower or tractor at any time. There is no safe place for riders.
10. Do not operate unless all personnel, livestock and pets are several meters away to prevent injury by thrown objects.
11. Before backing up, disengage the mower and look behind carefully.
12. Install and secure all guards and shields before starting or operating.
13. Keep hands, feet, hair and clothing away from moving parts.
14. This rotary mower is designed for use only on tractors with 540 rpm power take off.
15. Never operate tractor and mower under trees with low hanging limbs. Operators can be knocked off the tractor and then run over by the rotating blades.
16. The rotating parts of this machine have been designed and tested for rugged use. However, they could fail upon impact with heavy, solid objects such as steel guard rails and concrete abutments. Such impact could cause the broken objects to be thrown outward at very high velocities. To reduce the possibility of property damage, serious injury, or even death, never allow the cutting blades to contact such obstacles.
17. Frequently check mower blades. They should be sharp, free of nicks and cracks and securely fastened.

18. Stop mower immediately upon striking an obstruction. Turn engine off, remove key, inspect and repair any damage before resuming operation.
19. Stay alert for holes, rocks and roots in the terrain and other hidden hazards. Keep away from drop-offs.
20. Use extreme care and maintain minimum ground speed when transporting on hillside, over rough ground and when operating close to ditches or fences. Be careful when turning sharp corners.
21. Reduce speed on slopes and sharp turns to minimise tipping or loss of control. Be careful when changing directions on slopes. Do not start or stop suddenly on slopes. Avoid operation on steep slopes.
22. When using a unit, a minimum 20% of tractor and equipment weight must be on tractor front wheels. Without this weight, tractor could tip over, causing personal injury or death. The weight may be attained with a front end loader, front wheel weights, ballast in tires or front tractor weights. When attaining a minimum 20% of tractor and equipment weight on the front wheels, you must not exceed the ROPS weight certification. Weigh the tractor and equipment. Do not guess or estimate!
23. Inspect the entire machine periodically². Look for loose fasteners, worn or broken parts, pinched hydraulic hoses, and leaky or loose fittings.
24. Use only the driveline supplied with the mower. Do not use it if it is missing any shield or safety protection.
25. Pass diagonally through sharp dips and avoid sharp drops to prevent hanging up tractor and mower.
26. Avoid sudden starts and stops while travelling up or downhill.
27. Always cut down slopes; never across the face. Avoid operation on steep slopes. Slow down on sharp turns and slopes to prevent tipping and or loss of control.

3.02 - Set-up & Assembly Instructions

Notice to dealer: pre-delivery set-up and service including lubrication is the responsibility of the authorised dealer. It is up to you to assure that the machine is in perfect condition and ready to be used. It is your responsibility to ensure that the customer is aware of all safety aspects and operational procedures for the mower. You must also fill out the Pre-delivery Checklist³ prior to delivering the mower.

At times, due to loading restraints the mower is shipped with the three decks separate from the frame. It is the dealer's responsibility to ensure final assembly of the mower.

To hook the three mowers to the central frame, do the following:

1. position the decks complete with hitches (**see #8, fig. 3**) near the telescopic wing arms (**see #1, fig. 3**) which are bolted into the lift arms.
2. Insert the attaching pin (**see #7, fig. 3**) into the tube welded to the hitch (**see #9, fig. 3**). Place the shim washers (**see #5, fig. 3**) on either end of the attaching pin.

² See chapter 4 - Maintenance.

³ See chapter 7 - Pre-Delivery Checklist.

3. Place the two formed plates (see #3, fig. 3) on either end of the attaching pin (see #7, fig. 3) with the bend facing outward.
4. With the wing arms down level with the mower decks, position the telescopic wing arms (see #1, fig. 3) between the two formed plates (see #3, fig. 3). Attach them the bolts (see #10, fig. 3) provided.
5. Tighten the nuts (see #4, fig. 3) and bolts (see #10, fig. 3). Ensure after tightening, that the formed plates (see #3, fig. 3) move freely up and down over the attaching pin (see #7, fig. 3).
6. Using the grease fitting on the hitch (see #6, fig. 3), grease the attaching pin and formed plate.



CAUTION: stand clear of bands when cutting as they could be under sufficient tension to cause them to fly loose. Take care in removing bands and wire, they often have extremely sharp edges and cut very easily.

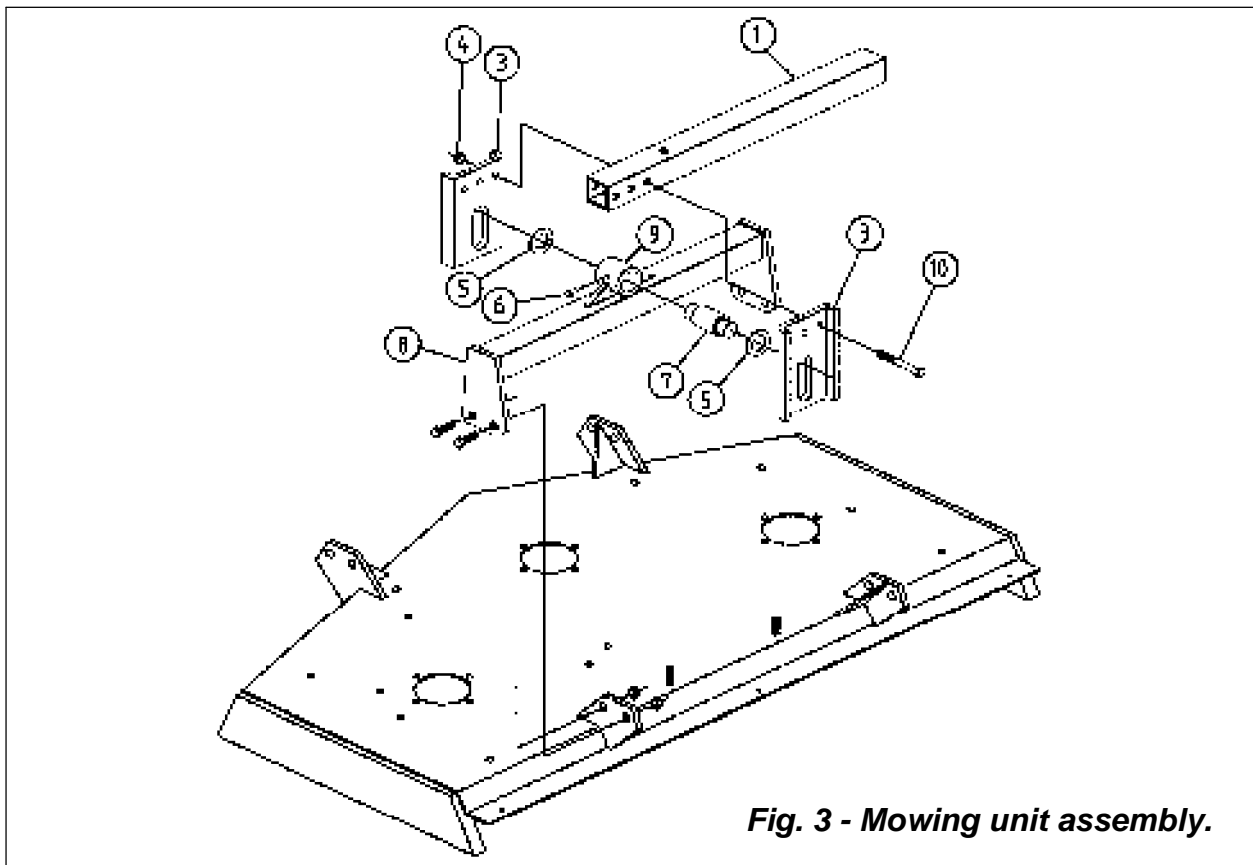

Fig. 3 - Mowing unit assembly.

3.03 - Cutting Height Adjustment



WARNING: keep hands and feet away from moving blades.

Be sure the tractor engine is off, parking brake is locked, and key is removed before making any adjustments.

Never rely on the hydraulic system to hold the weight of the raised mowers.

Never walk or work under the raised mowers without first making sure the automatic locking system is securely holding the wing units with the hydraulic cylinders closed, and the hook is engaged to support the rear deck.

Fig. 4

The cutting height is adjusted by moving the height adjustment spacers on the wheel yokes above or below the wheel arm.

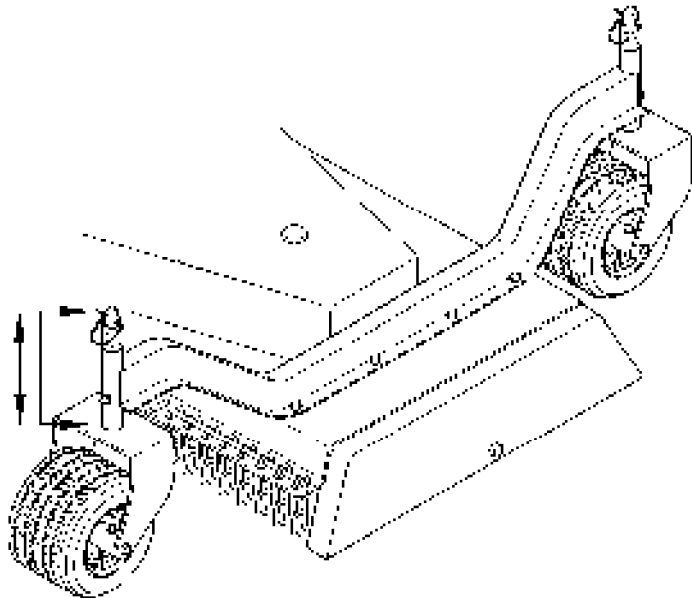

The cutting height is the distance from the blades to the ground. The cutting height is adjusted by **moving the height adjustment spacers on the wheel yokes above or below the wheel arm**. Placing spacers between the wheel arm and the wheel yoke raises the cutting height by the size of the spacer. Removing the spacers, lowers it by the same height (**see fig. 4**). All the wheel yokes are supplied with three different size height adjustment spacers, 6,25 mm. ($\frac{1}{4}$ "), 12,5 mm. ($\frac{1}{2}$ ") and 25 mm. (1").

Be sure all 12 wheels of the mowers are adjusted equally. This is the only way to ensure a completely uniform cut.

IMPORTANT: very low cutting heights should be avoided. Damaging shock loads occur when the blades strike the ground repeatedly. This can cause damage to the mower.

Cutting lower than 55 mm. (2") under most circumstances should be avoided. The cutting height is adjustable from 25 mm. to 125 mm. (1" to 5").

An anti-scalping roller is mounted on each deck for uneven ground contours. The roller rides the nose of the mower over a mound to help keep the nose from bulldozing or the blade from scalping the ground. This is extremely helpful when mowing particularly low.

3.04 - Pre-Operational Check

Check each of the following carefully prior to engaging the equipment:

1. the spindle bearings have been greased.
2. The belts for proper tension.
3. The oil in the gearboxes.
4. The drivelines cross & bearings have been greased.
5. All wheels are fully greased.
6. No wrappings or foreign objects are around the spindles, blades, or belts.
7. The blades are properly installed and the blade bolts properly torqued⁴.
8. All hardware is tight.
9. The tractor, to ensure correct direction of PTO and rpm speed.
10. All safety shields and guards are in place and tightly attached.
11. No people or animals are in the work area.
12. The Super-Flex frame is level to ensure its full floating capability.



WARNING: stay clear of rotating driveline. Entanglement in rotating driveline can cause serious injury. Disengage PTO, engage parking brake or place transmission in Park, shut off the tractor and remove the key before working around hitch, attaching or detaching driveline, making adjustments, servicing or cleaning the machine.

3.05 - Attaching to the Tractor

The Cyclone Super-Flex may be used on any 540 rpm tractor with a drawbar hitch and horsepower ranging from 25 to 80⁵.

⁴ See table 1, page 0.

⁵ See table 2, page 0.



CAUTION: check the tractor PTO rpm to ensure it is set at 540 rpm and turns clockwise.

Always ensure that the tractor tire pressure is correct according to the tractor operator's manual.

To attach the mower to the tractor do the following:

1. remove transport brace if it is installed.
2. Back the tractor up to the mower in order to slip the tractor drawbar hitch into the adjustable hitch bracket. The hitch bracket is adjustable in 3 different positions to conform to the tractor drawbar height. It may also be turned over for an additional 3 positions (see fig. 5). This is an important feature that permits the levelling of the Super-Flex frame. Be sure the pin you use can securely attach the mower to the tractor drawbar⁶. **Turn off the tractor engine.** Secure the frame hitch to the tractor drawbar with the pin. **Failure to ensure a secure coupling of the implement to the tractor can cause injury and damage to the implement or tractor.**
3. Lower jack stand until the weight of the mower is on the tractor drawbar. Turn the jack stand 90 degrees and pin into a horizontal position. For further safety, the jack stand may also be removed and mounted on the storage area on the tongue.

4. Hook the hydraulic hose to the tractor remote port. Engage the tractor hydraulics to raise all three mowers. **Do not stand or allow anyone to be under the mower while continuing the following steps.**

5. Lower the three mowers.

6. Install the Constant Velocity Drive. The CV end of the drive should be inserted into the CV end of the drive housing.

7. Check the frame to ensure it is level.

8. Engage the tractor PTO.

Fig. 5

Tongue height may be adjusted in 6 different positions to ensure a level frame on any tractor drawbar.

⁶ Optional equipment includes two different types of tractor hitch attachments; a swivel drawbar eye, for uneven terrain and a floating hitch for undulating terrain (see fig. 6).

⁷ See Raising the Mower Decks and the Automatic Lock Up System in section 3.08.

⁸ See section 3.06 - Constant Velocity Driveline.

⁹ See section 3.08 - Frame Adjustment.



DANGER: never engage the PTO until all three mowers are in the down position and resting on the ground. Never raise the mowers until all three deck blades have come to a complete stop. Doing so will cause damage to the driveline yokes and/or cross and bearings and can create a situation which endangers the operator or bystanders.

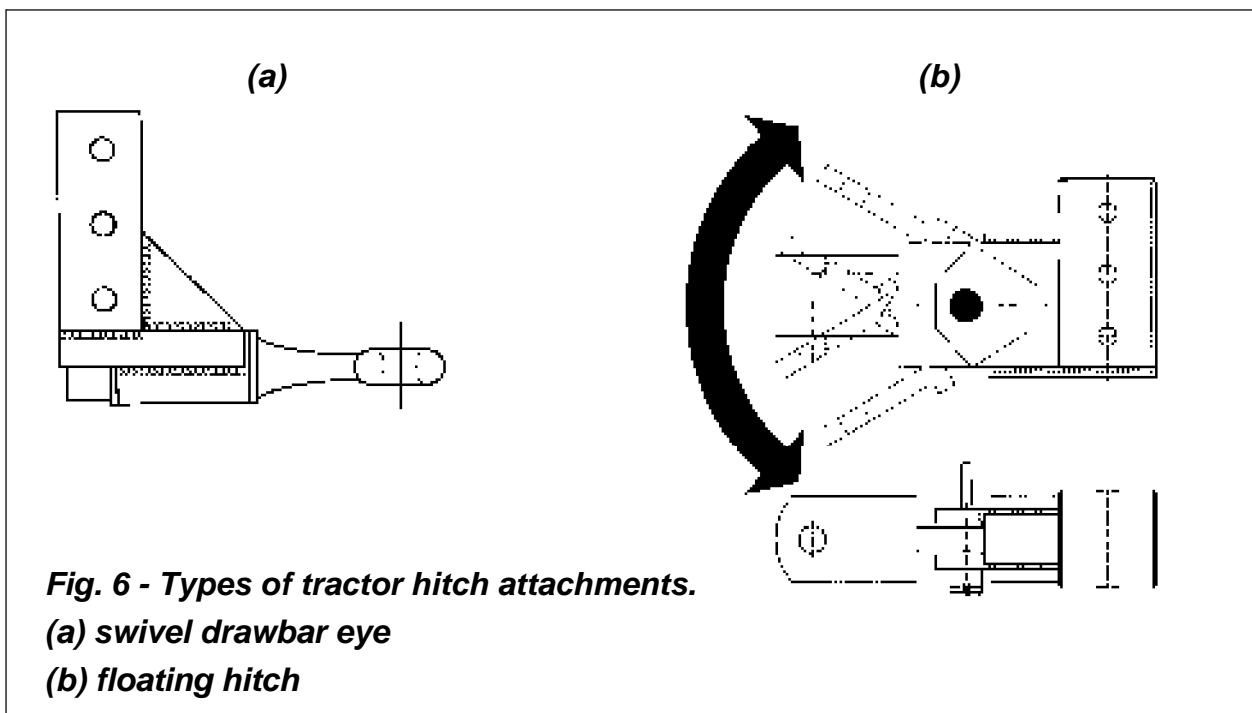

3.06 - Constant Velocity Driveline

It is extremely important that the Constant Velocity driveline be at the correct length in relation to the tractor on which it is to be used. The driveline length might be too long

for certain tractors whose tires allow for a very sharp turning radius. The proper length is one which allows for a maximum of overlap without the possibility of bottoming out on tight turns. **The bottoming out of the driveline can seriously damage the tractor PTO and/or the mower drive transmission.** We recommend the following method for determining the proper length. On the tightest turn possible (the tractor tires rubbing the frame tongue) the driveline should be at least 1,5-2,5 cm. (1/2"-1") from bottoming out. Keep in mind that the Constant Velocity driveline is rated at a maximum of 80 degrees turning radius. Towing a mower this size, most tractors cannot turn this sharply.

The following are instructions to prevent the possibility of bottoming out the driveline and causing damage to the tractor or the mower:

1. separate the two driveline halves. Connect the half with the CV joint to the tractor PTO and the other half to the mower input shaft.
2. Hook the tractor to the mower and turn the tractor in the tightest possible turn. Hold the half shafts side by side and mark the desired length on the outer female guard tube leaving a **1,5-2,5 cm. (1/2"-1") gap between the end of the guard tube and bell guard.**
3. Cut off both guard tubes the same amount as marked. Shorten both drive tubes the same amount as guard tubes.
4. De-burr and clean filings from the drive tubes and apply grease to the inside of the outer telescoping tube.
5. Re-measure as described in step 2. Straighten out the tractor and measure the two driveline halves to be sure that there is a minimum of 10-15 cm. (4"-6") shaft overlap to prevent the driveline from separating during normal operation.

3.07 - Hydraulic Lift System

Standard single action lift cylinders are used on the Super-Flex frame. They come standard with inline restrictors to prevent a sudden drop if the hydraulics fail.



DANGER: never use hydraulics without the restrictors installed.

For correct operation, the lift cylinders for all three mowers must be completely extended and relieved of pressure. This is done by assuring the tractor hydraulic remote system is in the float position. See your tractor operator's manual for correct procedure on how to operate single action hydraulic cylinders and most importantly on how to hold the tractor remote supply in float. Both wing mowers and rear mower must have free up and down movement for correct operation on uneven terrain.

3.08 - Frame Adjustments

The complex frame carrier consists of three main parts: the drawbar, the centre frame which supports the two side wing mowers and the rear axle where the rear mower is

attached and is carried by the transport tires. These three components are held together by numerous large 18x45 mm. bolts. The main objective of the frame carrier of the Cyclone Super-Flex is to allow the three mowing units to follow the ground contour and float freely and independent from each other. In order to achieve a perfectly uniform cut, it is important that all three mowers rest completely on the ground at all times with all of their four wheels touching. This ensures that each individual mower cuts level and maintains a uniform cut along the entire cutting width of the machine. The free floating concept is indispensable when cutting with gang mowers, a concept patented by our Company and not available to the competition.

The three units are connected to the frame by a double pivot set-up. The first at the overlapping pipes of the frame itself, the second in the telescopic arm attaching the mowers to the frame.

This articulating free floating system would not be possible without the complete release of all hydraulic pressure as you will see with the other important frame adjustments.

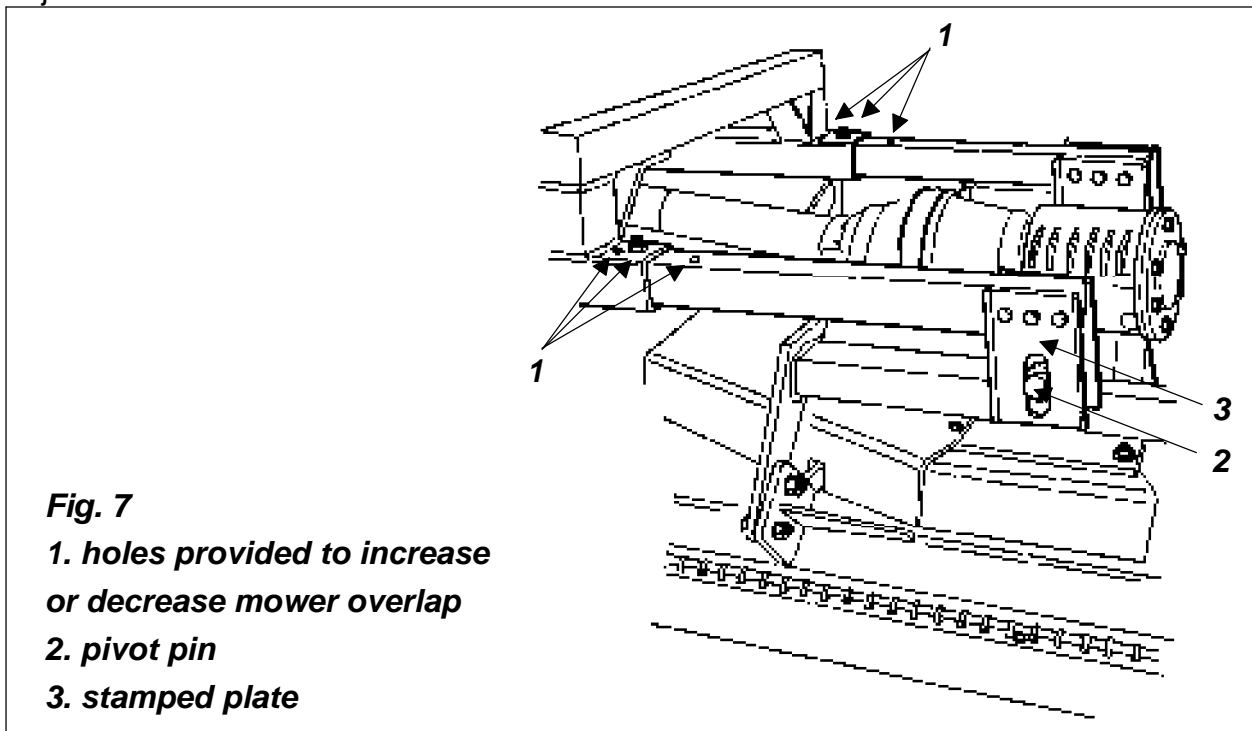

Telescopic Arms

The two wing mowers are connected to the frame with two adjustable telescopic arms¹⁰ each. This unique feature, available only on our mower, allows the wing decks to telescope in and out for additional overlap. Holes are provided for this purpose (see #1, fig. 7). With the holes provided you are able to adjust the cut overlap by up to 6+ per side. This is done by removing the retaining bolt and sliding the wing frame in or out to the desired position (see fig. 7). You may choose to drill holes for additional adjustment positions.

¹⁰ Read section 4.06 - Mower Driveline, prior to adjusting overlap width.

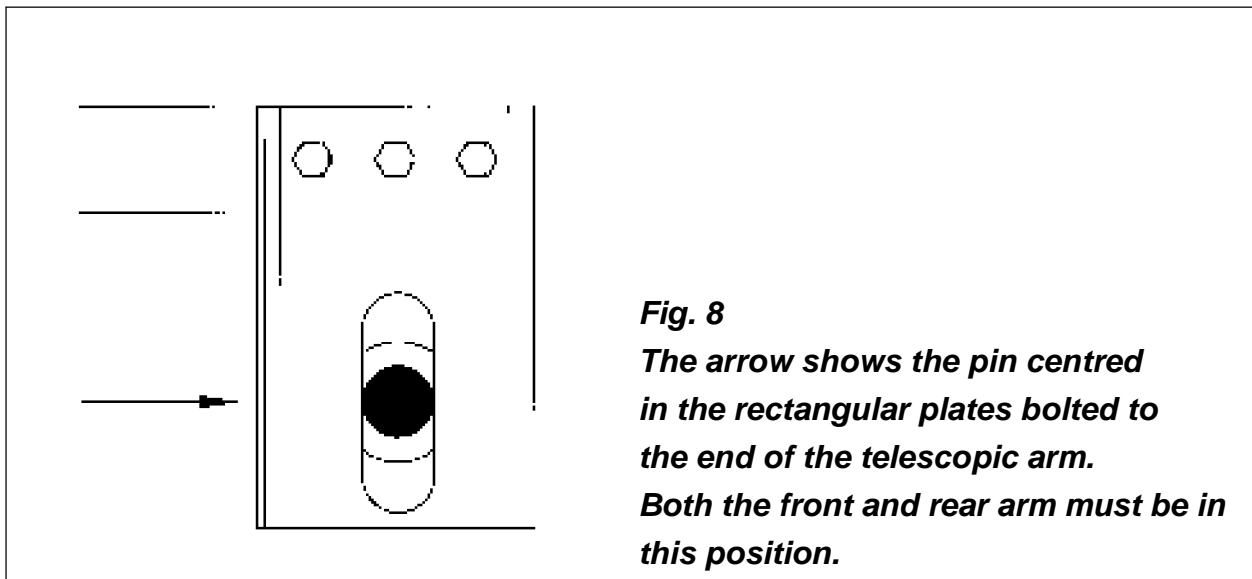

As the wing units, also the central unit is assembled to the frame with telescopic arms that are adjustable in several positions (see fig. 9 & 10).

IMPORTANT: always check PTO length when adjusting the deck overlap.

Levelling Super-Flex Frame

The second pivot point is where the telescopic arms connect to the mowers. Each deck has two pins, one in the front and one in the rear, nested between two stamped plates with large slots. The plates are attached to each of the frame arms with three bolts. As the mower floats over the ground, the slots allow it to follow the ground contour without interference (see fig. 8).

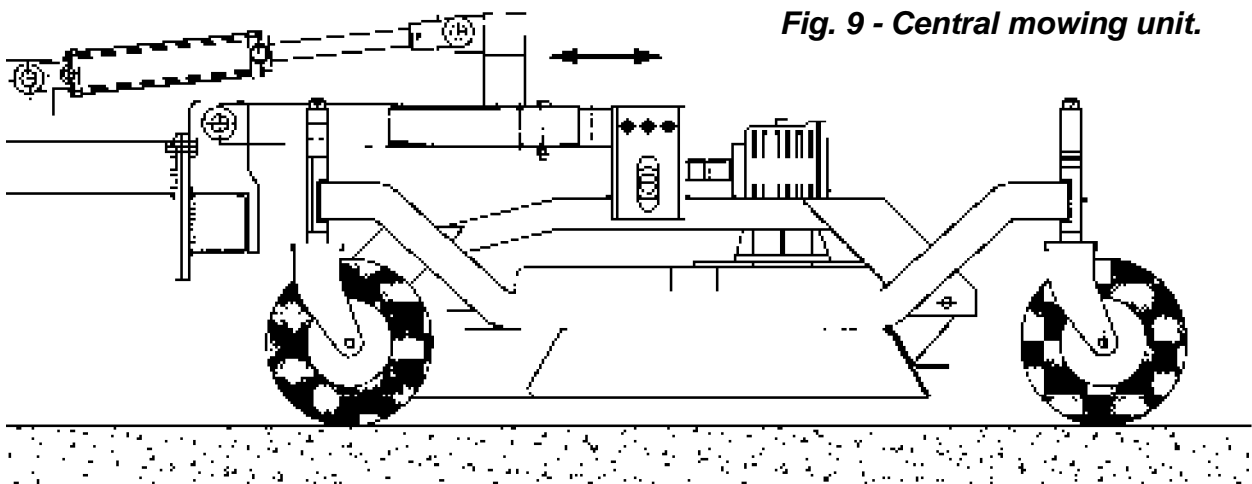

It is best to make levelling adjustments with the tractor and mower on flat ground. Lower all three mowing decks ensuring the hydraulic pressure from the tractor is completely released.

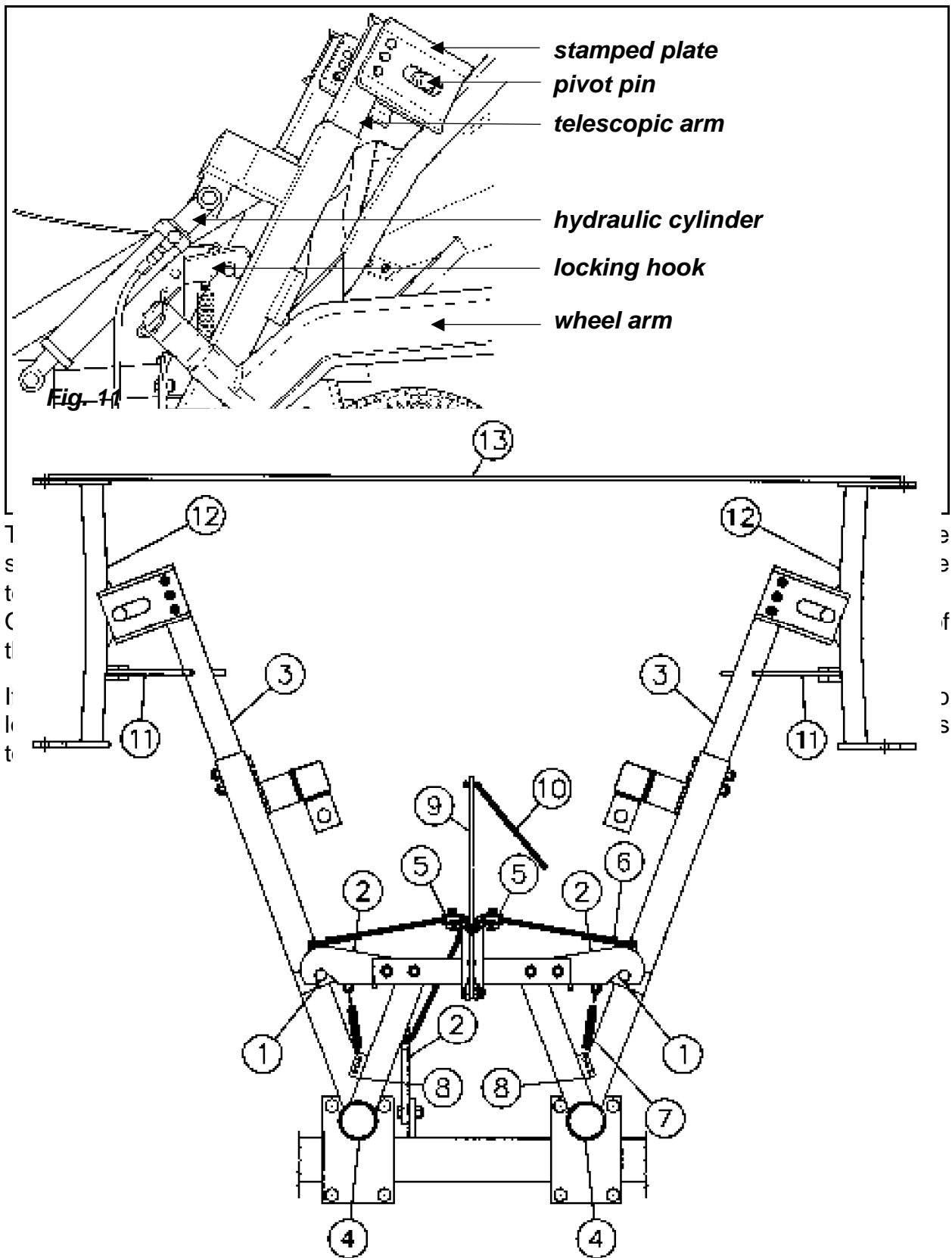

Before beginning work, ensure that all decks are level. Adjust the level of the mower by using one of the six positions available (**see fig. 5**) on the front hitch of the Super-Flex tongue¹¹. An additional adjustment on the carrier can be obtained with the transport tire system. The wheel axle mounting bracket comes with 8 holes, 4 for the upper position and 4 for the lower position. These two positions, along with the 6 different tongue positions give 12 different adjustment possibilities.

When the mounting brackets are in the upper position the tongue rises, with the bolts in the lower position, the tongue is lowered.

Raising the Mower Decks and the Automatic Lock up System

To lock the mower decks into a secure position, do the following (**see fig. 11**):

raise the three decks by means of the tractor hydraulics until the three locking hooks (2) ride up over the locking pins (1). Allow the mowers to float back down so the crook of the locking hooks sit securely over the pins and bracket.

Once the mower decks are raised, it is possible to lock the wings in a 90 degree vertical position for transport safety. Manually rotate the wing decks, they will pivot on the front and rear draw bars (12) up enough for the transport lock (11) to be positioned under the wing arm (3).

Bolt the metal transport brace (13) into the holes in the front draw bars (12) for added safety when the wing units are in the 90 degree vertical position (**see fig. 11**).

To lower the mowers, proceed as follows:

raise the three decks with the tractor hydraulics. When they are fully raised, pull the cord (10) tied to the unlocking lever (9) (this will pull the hooks away from the pins and mounting bracket), and lower the decks with the tractor hydraulics. Release the cord once the pins and mounting bracket are past the hooks¹².

¹¹ See section 3.05 - Attaching to the Tractor, for further details.

¹² In the place of the pull rope (10), a hydraulic cylinder is available for automatically unhooking the three mowing decks.

Before the three springs (7) have stretched to the point that they are unable to maintain good downward pressure and keep the hooks (2) in place it is important to move the hook of the springs to a lower hole (8).

3.09 - Start Up



WARNING: never engage the PTO until all three mowers are in the down position and resting on the ground. Never raise the mowers until all three deck blades have come to a complete stop. Doing so will cause damage to the driveline yokes and/or cross and bearings and can create a situation which endangers the operator or bystanders.

Before engaging the Super-Flex mower, ensure that all twelve mower tires are firmly on the ground. The two front wheels of the rear mower are locked into a non-swivelling position to prevent sliding of the mower while operating over a steep lateral hillside (see fig. 12).

With the engine idling, slowly engage the PTO drive. Move the throttle lever until the PTO speed indicated on the mower is obtained.

The mower is normally set for a PTO speed of 540 rpm. Shift the transmission to a slow speed gear and start forward, increase the ground speed by shifting upward until the desired speed is obtained. Do not mow in reverse unless absolutely necessary and only after careful observation of the area behind the mower.

Fig. 12

The two front wheels of the rear mower are locked into a non-swivelling position to prevent sliding of the mower while operating over a steep lateral hillside.

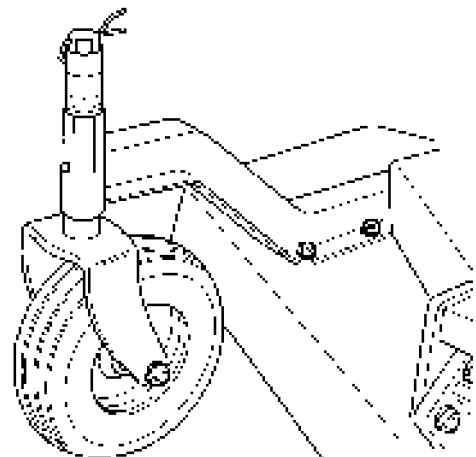

CAUTION: do not operate this mower at a PTO speed or direction of rotation other than that shown on the mower. Serious damage can occur to the machine and/or the operator.

Before starting to mow, never forget that the **operator is responsible** for the following:

1. safe and correct driving of the tractor and mower.
2. To learn precise, safe operating procedures for both the tractor and the mower.
3. To ensure all maintenance and lubrication has been performed on the mower.
4. To have read and understood all safety aspects for the mower in the operator's manual.
5. To have read and understood all safety decals on the mower.
6. Checking the condition of the blades. Worn or damaged blades should be changed before starting¹³.
7. Checking to ensure that the cutting edge is the leading edge of the blade.
8. Checking that there is no wire, weed, grass or other material wrapped around blades.
9. Checking to see if front weights to be added to the tractor in order to maintain balance.
10. Checking the tractor tires for the proper pressure in accordance with the tractor operator's manual.
11. **Checking that the PTO shield, belt shields and all other shielding are on the machine and securely in place.**
12. Making sure the proper attire is worn. Avoiding loose fitting clothing which can become entangled. Wearing sturdy, tough-soled work shoes and protective equipment for eyes, hands, ears and head. Never operate tractor or implements in bare feet, sandals or sneakers.
13. Checking area for stones, branches and other debris that might be thrown.
14. Ensuring proper

Fig. 13

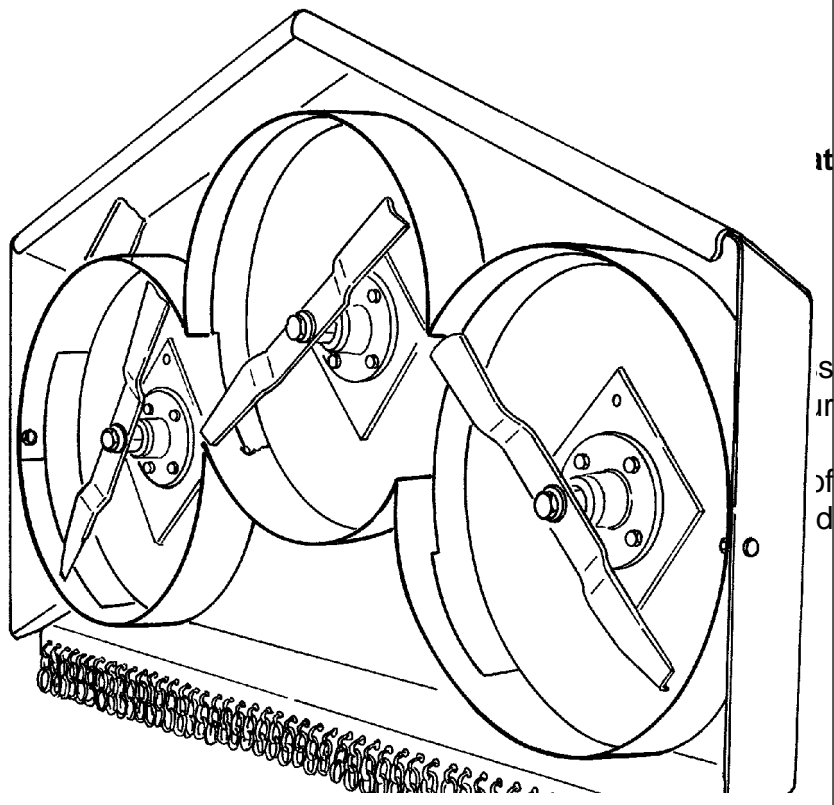
The mulching kit is
CAUTION: If available
might be thrown
for the rear discharge
mowers.
This kit, containing
3 multilevel cutting
edges blades and
add-ons containment
baffling which bolts
to the underside of
the mower deck,
mulches and
pulverizes grass
and leaves.



¹³ See section 4.03 - Blade Maintenance, for details.

If you are using a **mulching kit**, you need to reduce your ground speed to under 4 kph (2 mph) (**see fig. 13**).

The mulching kit is an optional kit available for the Super-Flex mowers. This kit, containing 3 multilevel cutting edge blades and add-on containment baffling which bolts to the underside of the mower deck, mulches and pulverises grass and leaves.

Another benefit of the mulching kit, is safety. In fact, the kit greatly reduces the possibility of thrown objects. This is particularly important when mowing around schools, public parks and golf courses.

In order to obtain the best cut possible, always keep the tractor rpm up to the speed indicated on the mower. When increasing or decreasing mowing ground speed, always use gear selection, not engine speed. This will maintain the constant maximum blade speed necessary for a clean cut.

3.11 - Operating Techniques

All of the following factors are important in selecting the proper forward speed:

1. height of grass.
2. Type of grass.
3. Density of grass.
4. Type of terrain.
5. Grass condition, wet or dry.
6. Blade type.

This mower has been designed to cut grass with heights from 10 to 20 cm. (4" to 8"). It is recommended to avoid cutting grass taller than 25 cm. (10").

For the best results, try cutting the grass at least once per week during growing season avoid taking more than 4-5 cm. (1½"-2") off the top. Tall dense grass should be cut at

low speeds, while thin medium grass can be cut at a faster ground speed. For cleaner cuts and more efficient mowing the blades must be kept sharp¹⁴. Always operate PTO at 540 rpm. This is necessary to maintain proper blade speed and obtain a clean cut.

Under certain conditions, tractor tires may roll some grass down and prevent it from being cut at the same height as the surrounding area. If this occurs reduce the tractor ground speed but maintain a 540 rpm. engine speed. The lower ground speed will permit the grass to at least partially rebound. Under some conditions grass will not rebound enough to be cut even, resulting in an uneven appearance. In general, lower cutting height gives a more even cut with less tendency to leave tire tracks. If cut is still not satisfactory, cut the area twice or use high lift blades.

Mow extremely tall grass twice. On the first pass use a high cutting height. On the second pass position the mower at the desired height and when practical mow at a right angle in travel to the first pass.

Plan your pattern to travel straight forward when ever possible.

It is better to cut grass more often than too short. Short grass deteriorates rapidly in hot weather and invites weed growth during growing season.

If at any time the mower should jam resulting in belt slippage of 2 or more seconds, raise the mower and continue for 2-3 minutes. This will allow the pulleys to cool and prolong belt life. Because of the size and high cutting speed of the Super-Flex mower, it is extremely important that the operator becomes familiar with its width while mowing around trees, buildings, etc. Since the Super-Flex mower cuts better at higher speeds it is indispensable that the operator knows the mower before entering into areas where trees, fences, curbs and other obstacles can be hit.



DANGER: pick up all rocks and other debris before mowing.

Enter new areas carefully. Cut grass higher at first, allowing mower to clear hidden objects.



CAUTION: for emergency reasons learn how to stop the tractor and mower quickly.

On the Cyclone Super-Flex mowers always disengage the PTO, lock parking brake, stop the engine and allow the mower blades to come to a complete stop before dismounting the tractor.

¹⁴ See Sharpening Blades in section 4.03 - Blade maintenance, for details.

3.12 - Uneven Terrain



WARNING: be careful of roll-over when operating tractor and mower over uneven ground.

In extremely uneven terrain rear wheel weights, front tractor weights, and/or tire ballast should be used to improve stability.

When mowing over uneven terrain, observe the type of terrain and develop a safe mowing pattern. Whenever traction or stability is doubtful, first test drive over the terrain with the PTO disengaged.

Operate the mower up and down steep slopes, not across slopes, to prevent the tractor from tipping. Avoid sudden stops and starts and slow down before changing directions on a slope.

Pass diagonally through sharp dips and avoid sharp drops to prevent hanging up the tractor and mower.

Slow down on sharp turns and slopes to prevent tipping or loss of control.

Avoid tipping the mower while cutting. Watch for holes, roots or other hidden objects. Do not cut near the edge of a gully, ditch or stream bank.

An anti-scalping roller is mounted on the mower for uneven ground contours. The roller rides the nose of the mower over a mound to help keep the nose from bulldozing or the blade from scalping the ground. One roller attached to each of the three decks is recommended when mowing over particularly uneven ground.

TABLE 1 - TORQUE SPECIFICATIONS

Diameter	Class 8.8		Class 10.9	
	N.m	lb.ft	N.m	lb.ft
M 8	25	18	35	26
M 10	50	37	70	52
M 12	90	66	125	92
M 14	140	103	200	148
M 16	215	155	305	225
M 18	295	217	420	309
M 20	420	302	590	438

When using locking nuts, increase torque values by 5%.

TABLE 2 - CYCLONE SUPER-FLEX - TECHNICAL FEATURES

Cyclone Super-Flex for tractors up to 80 HP, PTO 540 rpm, air tires, CV-PTO.									
Model	HP	Working width cm.	Overall width cm.	Weight Kg.	# Blades	Cutting height mm.	# Belts & type	# and Tire size	Driveline 1 3/8 +
S-FLEX-360	25-60	360	370	1280	9	25 - 125	6 SPBX	12-330x160	ASAE 6 th cat.
S-FLEX-450	30-60	450	460	1420	9	25 - 125	6 SPBX	12-330x160	ASAE 6 th cat.
S-FLEX-510	35-60	510	520	1560	9	25 - 125	6 SPBX	12-330x160	ASAE 6 th cat.
S-FLEX-600	35-80	600	610	1700	9	25 - 125	6 SPBX	12-330x160	ASAE 6 th cat.

4 - MAINTENANCE



DANGER: raise the three mower decks with the tractor hydraulics. Be sure all three automatic locking hooks are securely in place. Place the wing units in their 90 degree vertical position with the transport locks (see #11, fig. 11).

Stop the engine, lock parking brake and remove key and bolt on the transport brace (see #13, fig. 11). Never rely on the hydraulics alone to support the raised decks. Always use gloves and safety glasses when performing any maintenance. Keep fingers out of slots to prevent injury.

4.01 - Maintenance Safety

1. Good maintenance is your responsibility.
2. Keep service area clean and dry. Be sure electrical outlets and tools are properly grounded. Use adequate light for the job at hand.
3. Make sure there is plenty of ventilation. Never operate the engine of the towing vehicle in a closed building. The exhaust fumes may cause asphyxiation.
4. Make no repair or adjustments with the tractor engine running. Before working on the machine, disengage the PTO, shut off the engine, set the brakes, and remove the ignition key.
5. Be certain all moving parts on attachment have come to a complete stop before attempting to perform maintenance.
6. Never work under equipment unless it is blocked securely.
7. Never trust the hydraulic pressure alone to maintain the mowers in the raised position. When servicing the Super-Flex with the mowers in the raised positions always lock the wings with the three automatic locking hooks and bolt the transport brace (**see fig. 11**).
8. Always use personal protection devices such as eye, hand and hearing protectors, when performing any service or maintenance.
9. Frequently check mower blades. They should be sharp, free of nicks and cracks and securely fastened.
10. Periodically tighten all bolts, nuts and screws and check that all cotter pins are properly installed to ensure unit is in a safe condition.
11. Remove hydraulic pressure prior to doing any maintenance.
12. Never use your hands to locate a hydraulic leak on attachments. Use a small piece of cardboard or wood. Hydraulic fluid escaping under pressure can penetrate the skin.
13. When disconnecting hydraulic lines, shut off hydraulic supply and relieve all hydraulic pressure.

14. Do not attempt to mount a tire unless you have the proper equipment and experience to do the job.
15. Inflating or servicing tires can be dangerous. Whenever possible, trained personnel should be called to service and/or mount tires.
16. When completing a maintenance or service function, make sure all safety shields and devices are installed before placing unit in service.
17. After servicing, be sure all tools, parts and service equipment are removed.
18. Be sure to lock the tractor brake and either lock the wings with the transport brace or lower the mowers to the ground when completing work.
19. Never replace hex bolts with less than grade five bolts unless otherwise specified, i.e. shear bolts¹⁵.
20. Where replacement parts are necessary for periodic maintenance and servicing, genuine replacement parts must be used to restore your equipment to original specifications. The company will not claim responsibility for use of unapproved parts and/or accessories and other damages as a result of their use.
21. Unauthorised modifications to the machine may impair the function and/or safety of the machine and reduce its life. If equipment has been altered in any way from original design, the manufacturer does not accept any liability for injury or warranty.

4.02 - Service

The accompanying illustrations show lubrication points. The chart gives the frequency of lubrication in hours, based on normal operating conditions. Severe or unusual conditions may require more frequent lubrication.

Use a good quality SAE multipurpose type grease for all locations shown. Be sure to clean fittings thoroughly before using grease gun.

Use 90 wt. or 140 wt. gear oil in gearboxes.

Hourly:

1. check the condition of mower blades for nicks or dull edges. Sharpen if necessary.
2. Replace bent or damaged blades¹⁶.
3. Also check blades for damage after hitting an obstruction.
4. Clean foreign material from mower deck and belt area.

Every 8 hours:

1. **lubricate drivelines, lubricate caster wheels, wheel yokes and frame pivot points:** apply two or three shots of grease to the driveline cross and bearings and the telescoping shafts; apply the same amount to the wheel arm grease fittings (**see fig. 15**), the wheel grease fittings and the frame grease fittings (**see fig. 14, #1-12 for lubrication points**). See the driveline manufacturer operator's manual for further information on the drivelines.
2. **Gearbox oil level:** check gearboxes oil level, it should be between $\frac{1}{2}$ and $\frac{2}{3}$ full. If needed add either SAE 90 wt. or SAE 140 wt. gear oil.

¹⁵ Refer to table 1 - Torque Specifications, for head identification marking.

¹⁶ See Removing Blades in section 4.03 - Blade Maintenance, for details.

Fig. 14
Grease points on
Super-Flex frame.

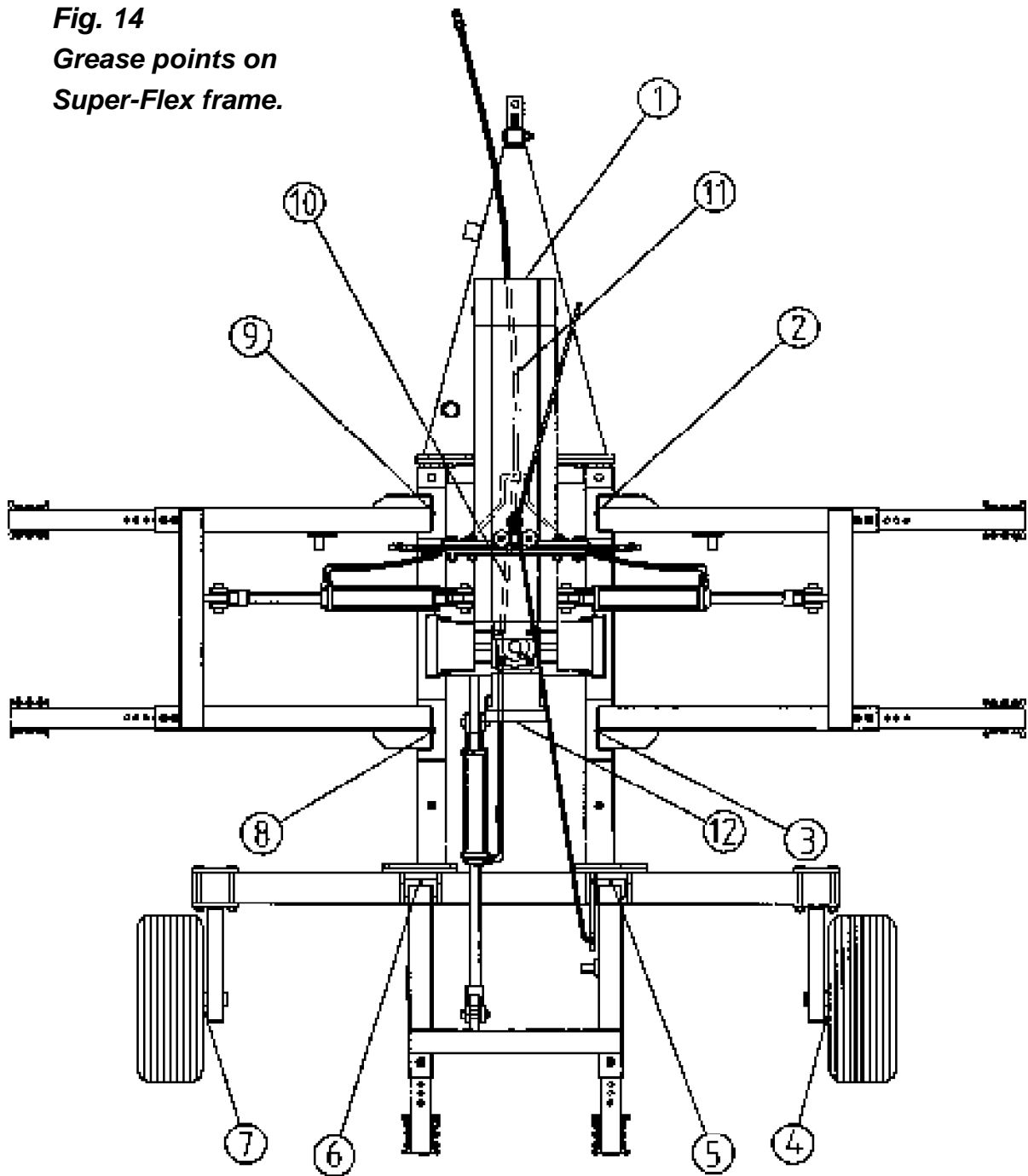

Every 25 hours:

check hardware tightness: mower vibration can loosen bolts¹⁷. Check tightness of the hardware periodically, using **table 1** as a guide.

Fig. 15 - Lubrication of wheel bearings and wheel yoke.

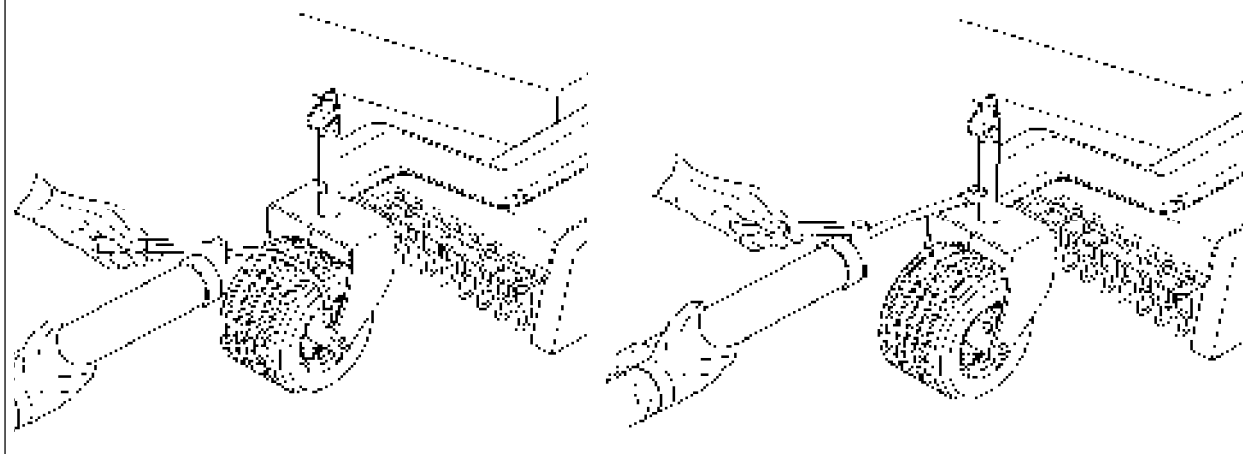
**Every 50 hours:**

1. lubricate the nine spindles with two or three shots of multipurpose grease (**see fig. 16**). The top grease fittings are easily accessible from the top of the deck by simply removing the plastic dust guards.
2. Check belt tension¹⁸.
3. Grease the main drive shaft carrier bearing (**see #1, fig. 14**).

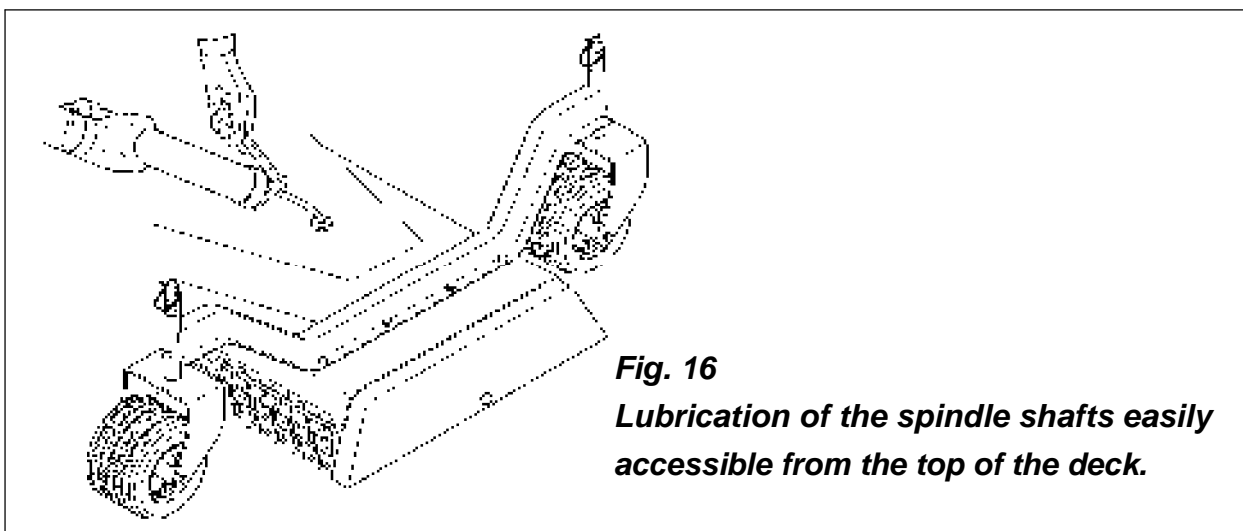

Fig. 16
Lubrication of the spindle shafts easily accessible from the top of the deck.

¹⁷ Table 1 gives the correct torque values for various bolts and nuts.

¹⁸ See section 4.04 - Belt Tension, for details.

Every 250 hours or at least once a year:
hand pack with fresh grease the main carrier wheel bearings on the Super-Flex frame
(see #4 and #7, fig. 14).

4.03 - Blade Maintenance



WARNING: to avoid possible injury, always wear proper eye and hand protection when servicing mower blades.

Mower's spindle assembly.

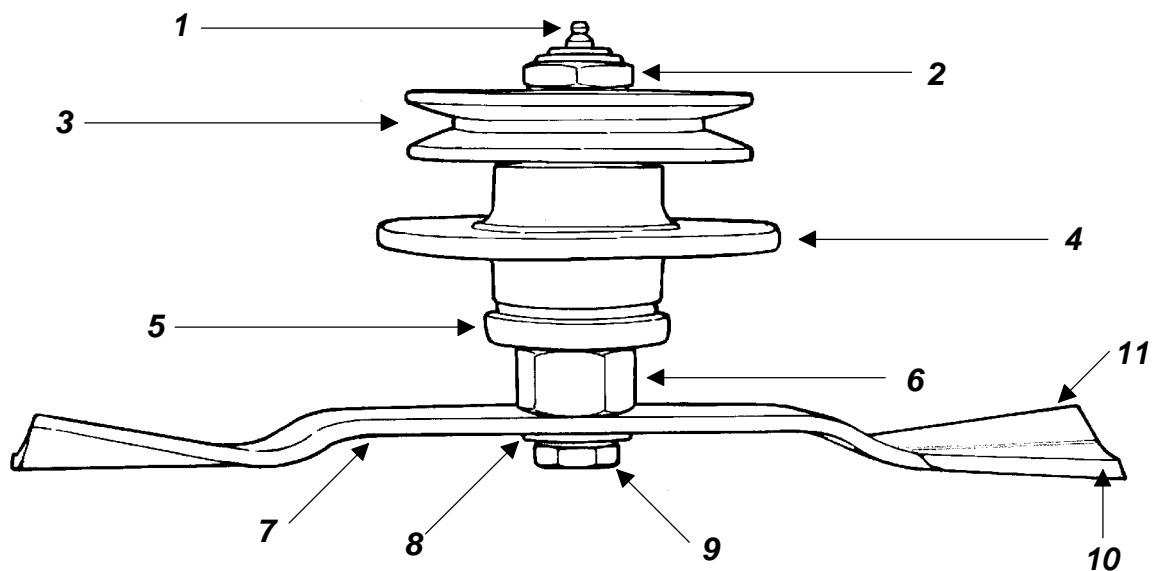

Fig. 17

Ground

- | | |
|-------------------|----------------------------------|
| 1. grease fitting | 7. blade |
| 2. hexagonal nut | 8. cup washer |
| 3. pulley | 9. blade bolt |
| 4. rotor support | 10. cutting edge close to ground |
| 5. cover | 11. lift wing |
| 6. shaft | |

In order for the mowers to work properly, always obtain a precision cut and lower HP requirements thus keeping cost down, proper blade maintenance is important.

Blades must be kept sharp, at their original length and with corners intact. A blade must be replaced if, due to wear or damage, its original shape has been distorted.

Removing or installing blades

To remove or install blades do the following:

1. the blade turns in a **counter clockwise** direction when viewed from the bottom of the deck. The cutting edge must be towards the direction of rotation. The lift wing of the blades is closest to the deck and the cutting edge away from it (**see fig. 17**).
2. Install the cup washer (**see fig. 17**) over the blade bolt and secure the blade in place as described above.
3. With a wrench, block the spindle and tighten the bolt to 140 N.m (103 lb.ft) (**see fig. 18**).
4. To remove the blades reverse the procedure.

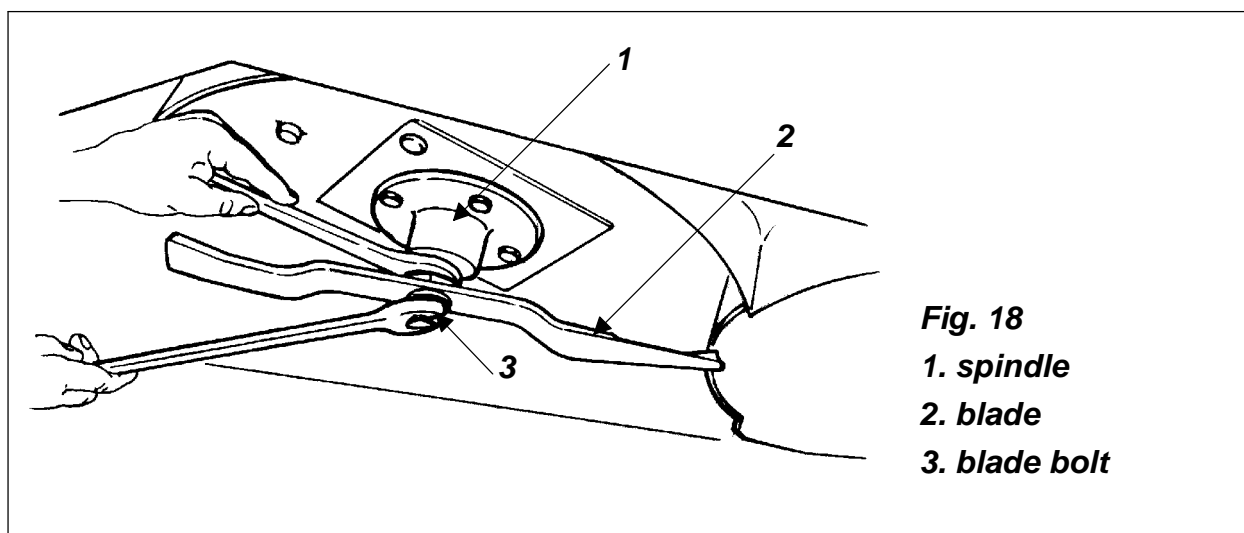

WARNING: do not substitute blades or any bolt for the blade retaining bolt. Company blades and blade retaining bolts are specially made for this application. Using non original parts can affect the quality of cut and may also cause damage to the mower.



DANGER: proper torque must be used when tightening the blade retaining bolt. If these safety precautions are not followed, the blade could come off during operation and be thrown tens of meters from the mower.

Sharpening blades

Blade sharpening is extremely important in order to get the best cutting results. Sharp blades permit a high quality cut and also reduces HP thus lowering costs.

To sharpen blades, first remove them following the above instructions.

Place the blade in a vise and sharpen them by using a hand file or grinder. **Do not** sharpen the blades to a sharp cutting edge. The cutting edge should be between 0,5-0,6 mm. ($1/64$ " to $1/32$ "") to prevent excessive pitting and dulling of the blades. Sharpen both ends of the blade equally for balance and always maintain corners. Always keep all three blades sharpened equally in order to maintain balance.



CAUTION: unbalanced or warped blades can cause damage to the mower and/or personal injury. Replace damaged blades before operating the mower. Sharpen both ends of the blades equally or until the blade is balanced.

4.04 - Belt Tension

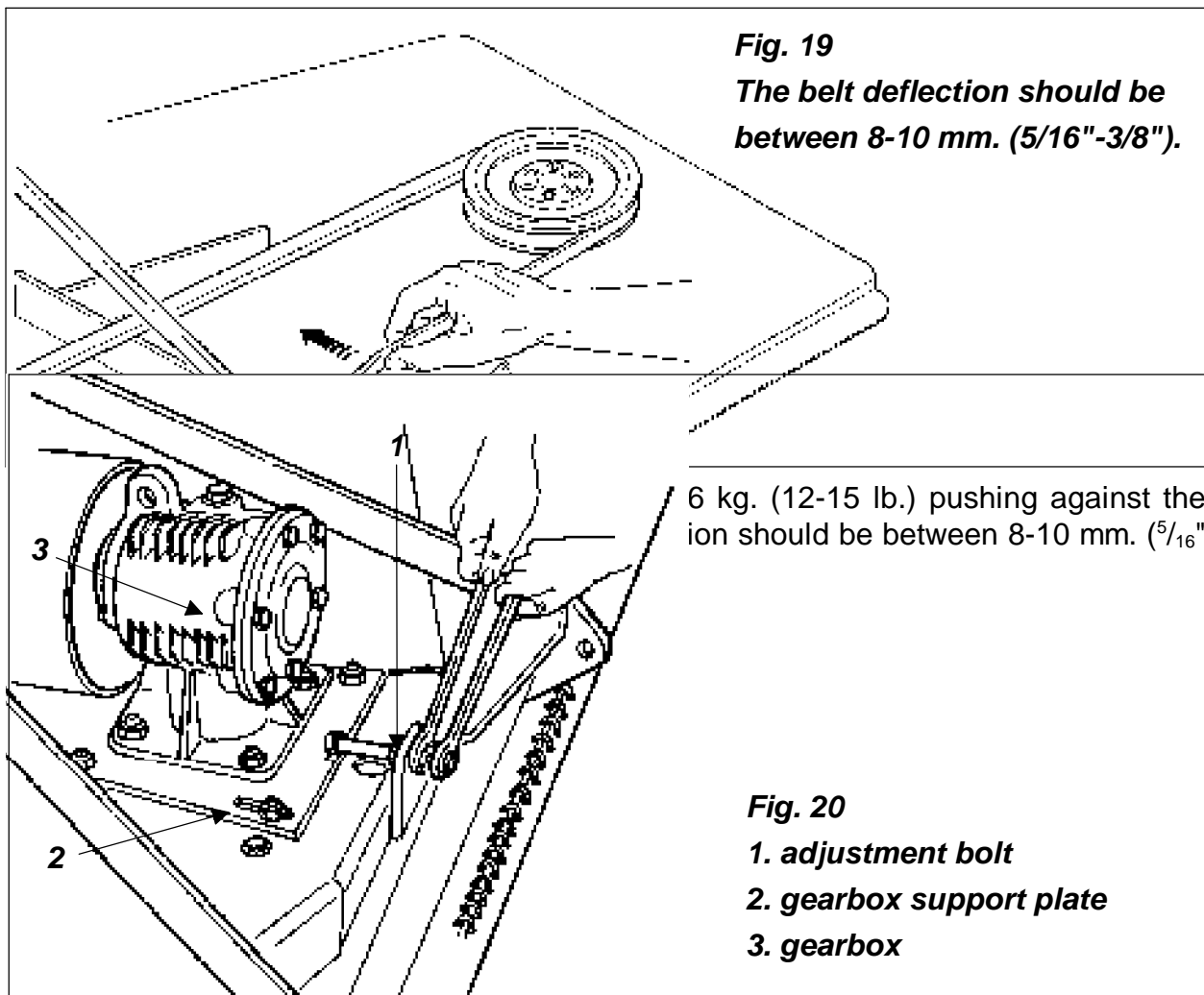

To adjust the tension do the following (**see fig. 20**):

1. remove belt shields. Clean foreign material from the mower deck and belt area.
2. Loosen the four nuts holding the gearbox support plate to the central plate.
3. Loosen the two blocking nuts on the adjustment bolt.
4. Turn the adjustment bolt counter clockwise until the proper belt tension is reached. This will draw the gearbox support plate to the rear, thus tightening the belts.
5. Tighten the two blocking nuts on the adjustment bolt.
6. Re-tighten the four nuts holding the gearbox support to the central plate.
7. Reinstall the belt shields.

4.05 - Belt Replacement

If the belts have been stretched or damaged to the point where the proper tension cannot be obtained they must be changed.

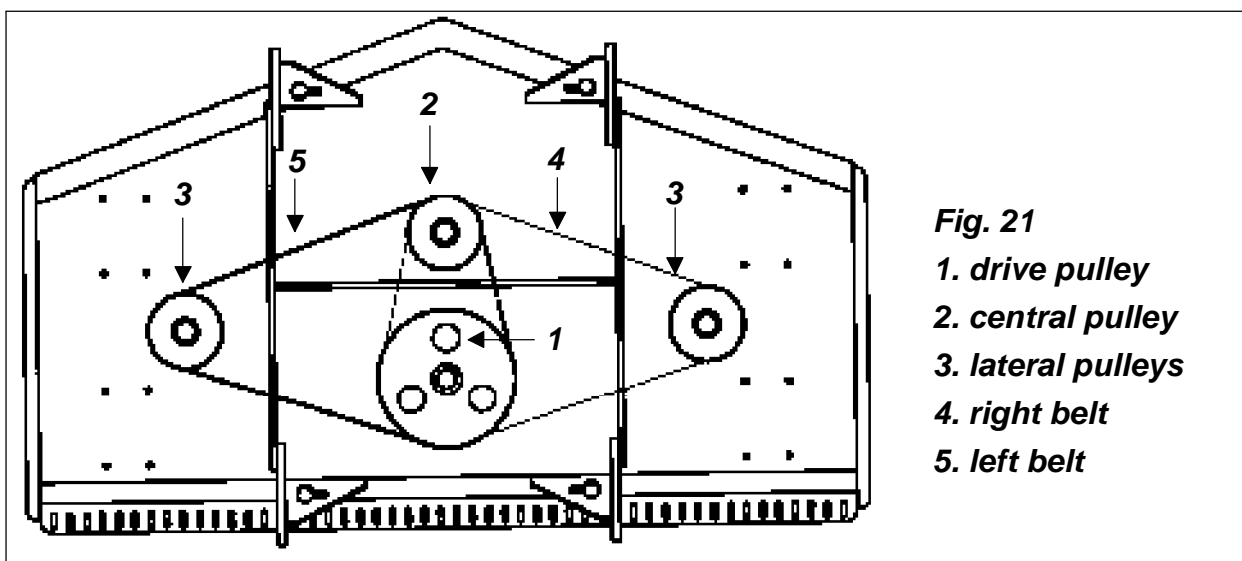

Fig. 21

1. drive pulley
2. central pulley
3. lateral pulleys
4. right belt
5. left belt

To replace belts do the following:

1. remove belt shields. Clean foreign material from the mower deck and belt area.
2. Loosen the four nuts holding the gearbox support plate to the central plate.
3. Loosen the two blocking nuts on the adjustment bolt (**see fig. 20**).
4. Turn the adjustment bolt clockwise, pushing the gearbox support plate forward until all tension is released.
5. Loosen rear nuts holding central plate (do not remove them).
6. Remove front nuts holding central plate.

7. Lift the front of the central plate and remove old belts.
8. Replace new belts (**see fig. 21**). Loop the first belt over the left spindle and around the lower groove of the centre spindle pulley and the lower groove of the gearbox drive pulley. The second belt connects the upper grooves of the centre spindle pulley and the gearbox drive pulley with the right spindle pulley.
9. Lower central plate.
10. Replace front nuts. Tighten front and rear nuts holding down central plate.
11. Turn the adjustment bolt counter clockwise until the proper belt tension is reached. This will draw the gearbox support plate to the rear, thus tightening the belts.
12. Tighten the two blocking nuts on the adjustment bolt.
13. Re-tighten the four nuts holding the gearbox support to the central plate.
14. Replace the belt shields.

4.06 - Drivelines and Centre Gearbox Timing

Fig. 22

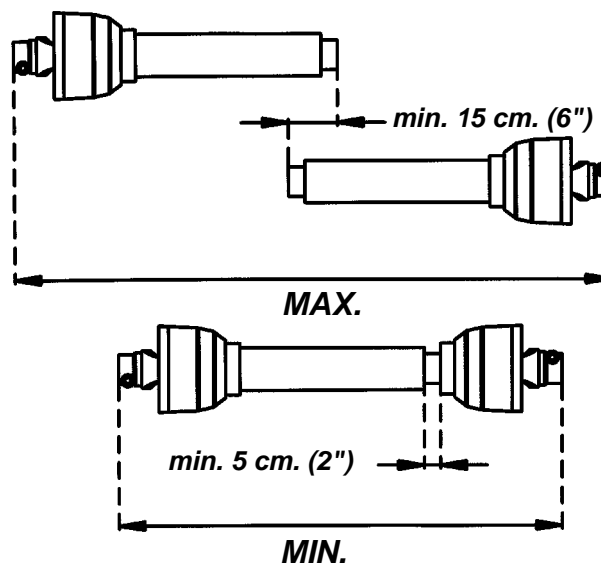

DANGER: only use the original driveline supplied with this mower, and always with the safety shielding in place.

Carefully read and file away the driveline operator's manual supplied by the manufacturer. The following does not substitute the information found in the driveline manual.

Your Super-Flex mower drivelines for the decks are cut to fit in order to deliver a maximum overlap when extended and without them bottoming out and damaging the mowers when the Super-Flex is folded into its transport position. It is important to try

and maintain approximately 5 cm. (2 $\frac{1}{2}$) from the two halves from bottoming out and a minimum of 15 cm. (6 $\frac{1}{2}$) overlap in the working position (**see fig. 22**).

If the wing mowers are moved in or out to change the overlap, or the drivelines are replaced with new ones, it is important to cut them to the proper length. To determine the correct length do the following:

1. separate the two driveline halves. Connect one half to the centre splitter gearbox and the other half to the mower gearbox.
2. Raise the mowers **slowly** with the hydraulics to the transport position. Hold the half shafts side by side and mark the desired length on the outer female tube guard leaving a 5 cm. (2 $\frac{1}{2}$) gap between the end of the guard tube and bell guard.
3. Cut off both guard tubes the same amount as marked in step 2.
4. Shorten both drive tubes to the same amount as guard tubes.
5. De-burr and clean filings from drive tubes and apply grease to outside of inner telescoping tube.

Reassemble the driveline halves. Raise and lower mowers again **slowly** to be sure drivelines do not bottom out in shortest position.

If for any reason, such as when lubricating driveline sections, the wing unit drivelines are detached from the main centre gearbox, extreme care must be used when reattaching to maintain the two side gearbox output shafts in a 'timed' position. A 'timed' position is a position where both the left and right wing universals are almost in line and allows the wings to fold up together in unison. If they are aligned at 90 degrees from one another, only one can fold up and the other yoke will be damaged by the hydraulics.

Tip: to accomplish this, make a mark on the centre gearbox and on the driveline yoke before removing the left and right drivelines. When reattaching the drivelines be sure that these marks line up.

4.07 - Transport



CAUTION: comply with state and local laws governing safety and movement of farm machinery on public roads. When driving the tractor and equipment on the road under 32 kph (20 mph), at night or during the day, use flashing amber warning lights and a Slow Moving Vehicle (SMV) identification emblem. Do not exceed 32 kph (20 mph). Reduce speed on rough roads and surfaces. Always install transport locks before transporting the mower. Drive tractor and mower safely. Do not drink and drive.

Stop the tractor, leave the engine running and disengage the tractor PTO. **Be sure the blades have come to a complete stop before continuing.** Set the parking brake.

Raise the three decks by means of the tractor's hydraulics until the three locking hooks ride up over the locking pins and rear mounting bracket. Allow the mowers to float back down so the crook of the locking hooks sit securely over the pins and bracket. **Only transport very short distances this way.** Do not trust the hydraulics alone except for extremely short distances, such as between trees, over bridges, etc. and only when you are sure no bystanders are near.

To transport over extended distances, the wing units should be secured in place with the transport brace provided (**see #13, fig. 11**). This will keep the wing units in a vertical position and cut down dramatically on the transport width.

The transport tires are not for highway use. Transportation for other than a very short distance should be done with a trailer.

When transporting the Super-Flex mower, maintain a safe speed and slow down when approaching turns.

4.08 - Storage



CAUTION: following operation, or when unhooking, stop the tractor, set the brakes, disengage the PTO, shut off the engine and remove the ignition key. Store the unit in an area away from human activity. Do not permit children to play on or around the stored unit. Make sure all parked machines are on a hard, level surface and engage all safety devices.

After seasonal use it is important to perform the following for prolonged storage:

1. raise the mowers and lock them in place with the hooks and if possible the transport braces.
2. Wash the mower carefully.
3. Inspect the mower and replace worn or damaged parts.
4. Tighten all hardware. Grease all areas indicated under maintenance.
5. Loosen the belts if the mower is to be stored for an extended length of time.
6. Cover the mower from the elements in order to have it in perfect condition for the start of the next season.

5 - REPAIR PROCEDURES



CAUTION: all repair procedures must be done by authorised dealerships. It is not recommended that untrained individuals perform any repair work. The following operations are detailed for qualified personnel only.

5.01 - Gearbox

To remove the gearbox from decks do the following:

1. remove the belt guards.
2. Loosen the nuts holding the gearbox support plate (**see fig. 20**).
3. Loosen the nut and turn the bolt in order to push the gearbox forward and release tension on the belts (**see fig. 20**).
4. Remove the belts¹⁹.
5. Remove the nuts holding the central plate to the frame.
6. Remove the nut holding the pulley to the gearbox pinion shaft. Remove the pulley.
7. Unbolt the nuts holding the gearbox support plate to the central plate (**see fig. 20**). Remove gearbox and gearbox support plate.
8. Unbolt the nuts holding the gearbox to the gearbox support plate. Remove the gearbox.

If it is necessary to replace any part on the inside of the gearbox, it is important to replace oil seals or gaskets to ensure a tight fit when reassembling.

To replace the gearbox, follow the above instructions in reverse order.

5.02 - Blade Spindle

To remove a blade spindle do the following:

1. remove the belts²⁰.
2. Remove the nut holding the pulley to the spindle shaft (**see fig. 17**).
3. Remove the blades²¹.
4. Unbolt the bolts holding the rotor support to the mower deck.
5. If necessary remove and replace the bearings from the rotor using presses or extractors.
6. Reassemble in reverse order **ensuring that the nut securing the top pulley (see fig. 17) is tightened to 160 N.m (108 lb.ft).**

¹⁹ See section 4.05 - Belt Replacement.

²⁰ See section 4.05 - Belt Replacement.

²¹ See section 4.03 - Blade Maintenance.

5.03 - Suggested Spare Parts

It is suggested that the following spare parts be kept on hand at all times to prevent a minor problem from delaying work.

Description	Quantity
Blades	9
Blade bolts and washers	9
Belts	3 set
Wheels	2
1+ Spacers	4
1/2+ Spacers	2
1/4+ Spacers	2
Cotter pins	8

6 - TROUBLESHOOTING



WARNING: be sure the tractor's engine is off, parking brake is locked, and key is removed before making any adjustments.

PROBLEM	POSSIBLE CAUSE	SOLUTION
Uneven cutting.	Cup washer not between blade and bolt. Ground speed too fast. Blades need sharpening. Caster wheels uneven.	Check washer location at all three spindles. Shift to lower gear. Sharpen blades. Adjust wheel position.
Blades turning but not cutting.	Direction of blades is wrong. Splitter gearbox R&R to wrong position.	Blade should turn CCW when you face deck bottom. See installing blade section. Rotate splitter gearbox to proper position.
Belt slippage.	Lack of tension. Object clogging mower. Debris in sheaves.	Tighten belt. Remove object. Clean sheaves.
Mower vibrates.	Object wrapped around blade. Belt damaged.	Remove object. Replace belt.
Belt squeal.	Belt slipping.	Tighten belt.
Grass build up at exit.	Wet grass. Grass too high. Tractor rpm too slow. Ground speed too slow.	Allow grass to dry. Raise mower, shift to lower gear, make two passes over grass. Mow grass high 1 st pass, 2 nd pass cut to desired height. Increase tractor rpm, check engine and PTO speeds. Increase ground speed.
Belts are tight when installing.	Wrong belt size. Belts installed incorrectly.	Check belt size. See Replacing Belts section.
Streaking conditions in swath.	Too wet to mow. Blades cannot cut grass pressed down by wheels. Dull blades. Blades worn down, preventing overlap. Mowers not overlapping. Not enough lift.	Allow grass to dry. Maintain engine speed and shift to lower gear. Sharpen blade. See sharpening blades section. Change blades. Move side mowers in. Use high lift blades.
Cut grass windrows.	Ground speed too slow. Tractor rpm too low.	Increase ground speed. Increase tractor rpm, check engine and PTO speeds.

7 - PRE-DELIVERY CHECKLIST

To the dealer: inspect the machine thoroughly after assembly to assure it is functioning properly before delivering it to the customer. The following checklist is a reminder of points to cover. Check off each item as it is found satisfactory or after proper adjustment is made.

- Gearbox oil level.
- Guards and shield properly fastened.
- Lubrication of grease fittings.
- All hardware properly tightened.
- All decals properly located and readable (**see fig. 2**).
- Blades properly installed, blade bolts & nuts tightened.
- Overall condition (touch up scratches, clean and polish).
- Test run, check for excessive vibration or overheating of bearings.
- Operator's Manual.

Review the operator's manual with the customer. Explain the following:

- Warranty.
- Safe operation and service.
- Correct machine installation and operation.
- Daily and periodic lubrication, maintenance and inspections.
- Troubleshooting.
- Operational procedures and storage.
- Parts and service.
- Remove and fill out the Delivery and Warranty Registration form.
- Give customer the operator's manual and encourage the customer to read the manual carefully.

IMPORTANT: warranty is not valid unless Delivery and Warranty Registration Form in operator's manual is completed in detail and mailed to the Company.

Model Number: _____

Serial Number: _____

Delivery Date: _____

Dealer's Signature: _____

8 - WARRANTY

The Company warrants its machine from defects in material and workmanship. The machines are warranted from the invoice date for the following periods.

1. **24 months** for private use.
2. **12 months** for commercial, contractual and public use.
3. **30 days** for loan or rental.

This warranty is valid only if the Warranty Registration Form is properly completed and sent to the Company within 14 days of delivery along with copy of the invoice.

This warranty is valid only if the machine is paid for in full.

The warranty coverage shall not be transferable from the first owner to any subsequent owner.

This document is the only warranty for this machine, any other promises, express or implied other than those set forth herein are not applicable.

The customer can not request any special provisions or changes to this warranty covering additional responsibilities or liability from the Company.

The Company determines whether the warranty covers the substitution or the repairing of the machine or parts.

The customer is responsible, in all cases, for expenses of lubricants, transportation, any custom duties and applicable taxes.

The substitution or the repair of parts under warranty do not extend the length of said warranty.

This limited warranty does not apply to and excludes drivelines and driveline related safety devices (shear pin yokes, shear pins, slip clutches, clutch discs), tires, belts, blades and other wear items.

At no time will the responsibility of the Company surpass the original purchase price of the machine. The purchaser agrees, not to have any rights to any compensation from the Company, including but not limited to, any eventual damages or accidents, loss of profit, loss of sales, injuries or damages of any kind or nature, or other accidents or losses which could result.

If during the period covered by this warranty, the machine fails to perform due to material or workmanship defects, the purchaser is to immediately make the Company aware of this defect. It is the Company's right to determine if the machine is to have parts replaced, repaired or the machine returned.

The Company will not accept any returned items without prior express written authorisation.

This warranty does not cover cost of labour for the replacement of parts.

Misuse or use of this machine other than ways outlined in the operator's manual or literature invalidates this warranty.