

ROTOMECH

'GREEN-RITE 125-145-165'

Macchina per l'aerazione e la semina

Seeder-cultivator and overseeder-aerator

Machine pour l'aération et l'ensemencement du gazon

Maschine zur Wiederherstellung von Grünanlagen

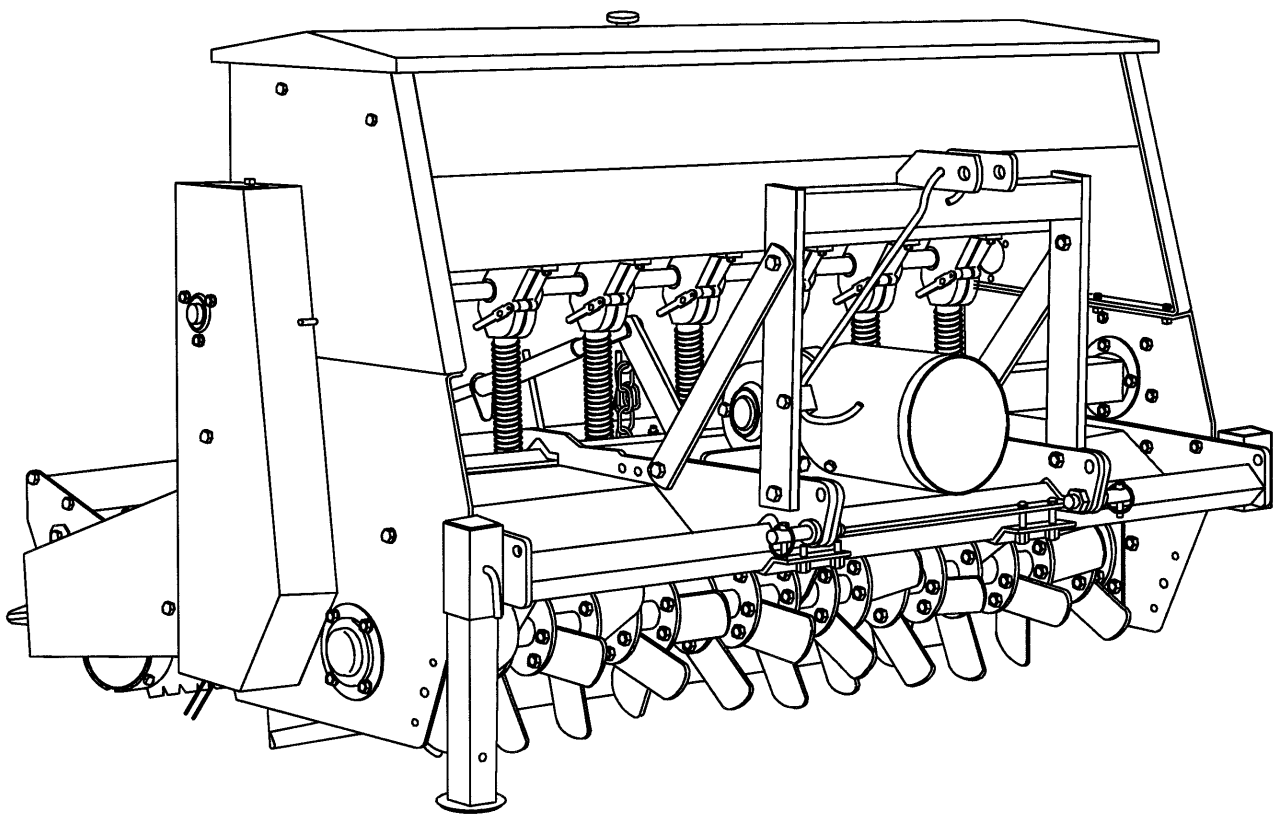

Rotomec: 'Green-Rite 125-145-165'

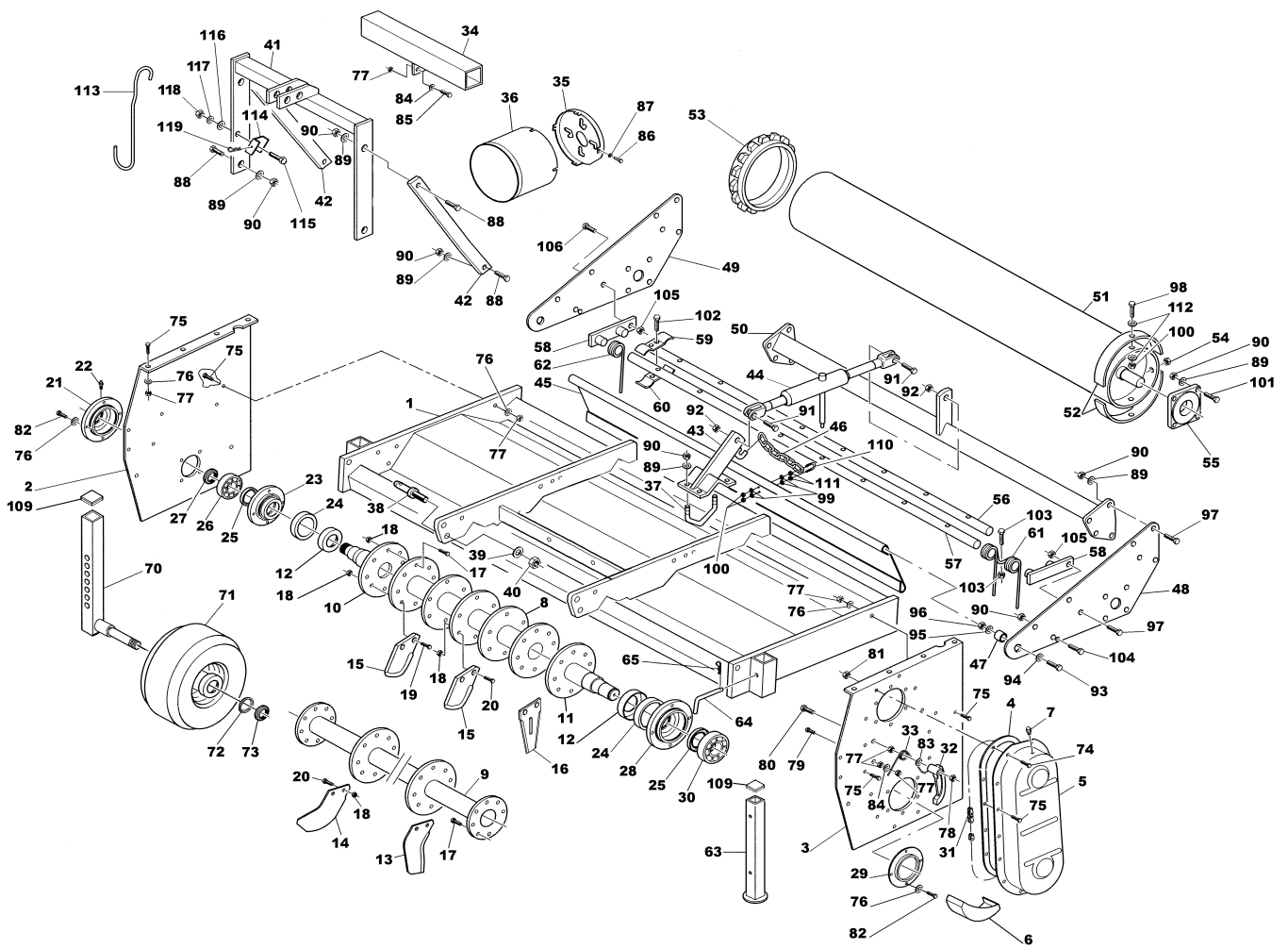

Rotomec: 'Green-Rite 125-145-165'

N.	COD.	DESCRIZIONE	DESCRIPTION	DESCRIPTION	BESCHREIBUNG	N.
1	0084701	Telaio v.145	Frame v.145	Châssis v.145	Rahmen v.145	1
	0084702	Telaio v.165	Frame v.165	Châssis v.165	Rahmen v.165	1
	0184751	Telaio v.125	Frame v.125	Châssis v.125	Rahmen v.125	1
	0284751	Telaio v.145 dal 09/2002	Frame v.145 since 09/2002	Châssis v.145 depuis 09/2002	Rahmen v.145 ab 09/2002	1
	0384751	Telaio v.165 dal 09/2002	Frame v.165 since 09/2002	Châssis v.165 depuis 09/2002	Rahmen v.165 ab 09/2002	1
2	0084028	Fianco destro	Right side panel	Tôle droite du châssis	Rechte Flanke	1
3	0084041	Fondo carter	Drive panel	Tôle gauche du châssis	Gehäuseboden	1
4	0022032	Guarnizione	Gasket	Joint d'étanchéité	Dichtung	1
5	0011030	Coperchio carter	Chain case cover	Carter d'engrenages	Carterdeckel	1
6	0024027	Salvacarter	Chain case cover protection	Protection carter	Gehäuseschutz	1
7	0010035	Sfiatatoio	Breather cap	Bouchon d'huile	Gehäuseentlüfter	1
	0001107A	Sfiatatoio dal 06/2005	Breather cap since 06/2005	Bouchon d'huile depuis 06/2005	Gehäuseentlüfter ab 06/2005	1
8	0284067	Rotore a lame v.125	Aerator rotor v.125	Rotor à lames v.125	Hackenrotor v.125	1
	0084032	Rotore a lame v.125 dal 01/2007	Aerator rotor v.125 since 01/2007	Rotor à lames v.125 depuis 01/2007	Hackenrotor v.125 ab 01/2007	1
	0084067	Rotore a lame v.145	Aerator rotor v.145	Rotor à lames v.145	Hackenrotor v.145	1
	0184032	Rotore a lame v.145 dal 01/2007	Aerator rotor v.145 since 01/2007	Rotor à lames v.145 depuis 01/2007	Hackenrotor v.145 ab 01/2007	1
	0184067	Rotore a lame v.165	Aerator rotor v.165	Rotor à lames v.165	Hackenrotor v.165	1
	0284032	Rotore a lame v.165 dal 01/2007	Aerator rotor v.165 since 01/2007	Rotor à lames v.165 depuis 01/2007	Hackenrotor v.165 ab 01/2007	1
9	0284046	Rotore v.125 (optional)	Tiller rotor v.125 (optional)	Rotor v.125 (option)	Rotor v.125 (Zubehör)	1
	0084046	Rotore v.145 (optional)	Tiller rotor v.145 (optional)	Rotor v.145 (option)	Rotor v.145 (Zubehör)	1
	0184046	Rotore v.165 (optional)	Tiller rotor v.165 (optional)	Rotor v.165 (option)	Rotor v.165 (Zubehör)	1
10	0084051	Perno destro rotore	Right flanged pivot	Pivot droit	Rechter Rotorstift	1
11	0084055	Perno sinistro rotore	Left flanged pivot	Pivot gauche	Linker Rotorstift	1
12	0022074	Coperchiella paraterra (da saldare)	Dirt shield (requires welding)	Couvercle pare-boue (demande soudure)	Schmutzschutz (man braucht Schweißung)	2
13	0030104S	Zappetta ad elica sinistra (optional)	Left C blade (optional)	Houe à hélice gauche (option)	Linke Schraubenhacke (Zubehör)	-
14	0030104D	Zappetta ad elica destra (optional)	Right C blade (optional)	Houe à hélice droite (option)	Rechte Schraubenhacke (Zubehör)	-
15	0002645	Coltello	Blade	Couteau	Messer	-
16	0084061	Coltello reversibile (optional)	Reverse blade (optional)	Couteau réversible (option)	Umkehrbares Messer (Zubehör)	-
17	0001073	Vite TE M12x35	Bolt TE M12x35	Vis TE M12x35	Schraube TE M12x35	8
18	0021105	Dado M12	Nut M12	Ecrou M12	Mutter M12	-
19	0084073	Vite TE M12x40	Bolt TE M12x40	Vis TE M12x40	Schraube TE M12x40	8
20	0021104	Vite TE M12x30	Bolt TE M12x30	Vis TE M12x30	Schraube TE M12x30	-
21	0030091	Coperchiella esterna destra	Right outer cover	Couvercle externe droit	Rechter Außendeckel	1
22	0001065	Ingrassatore M10-1.00	Grease fitting M10-1.00	Graisseur M10-1.00	Schmiernippel M10-1.00	1
23	0084081	Supporto destro completo	Complete right support	Palier droit complet	Rechte komplette Auflage	1
24	0084083	Tube parapolvere (da saldare)	Dirt shield (requires welding)	Couvercle pare-boue (demande soudure)	Schmutzschutz (man braucht Schweißung)	2
25	0057567	Paraolio 40.56.8	Oil seal 40.56.8	Pare-huile 40.56.8	Simmering 40.56.8	2
26	0030094	Cuscinetto 6306	Bearing 6306	Roulement 6306	Lager 6306	1
27	0030095	Ghiera M30x1,5	Safety nut M30x1,5	Frette M30x1,5	Nutmutter M30x1,5	1

Rotomec: 'Green-Rite 125-145-165'

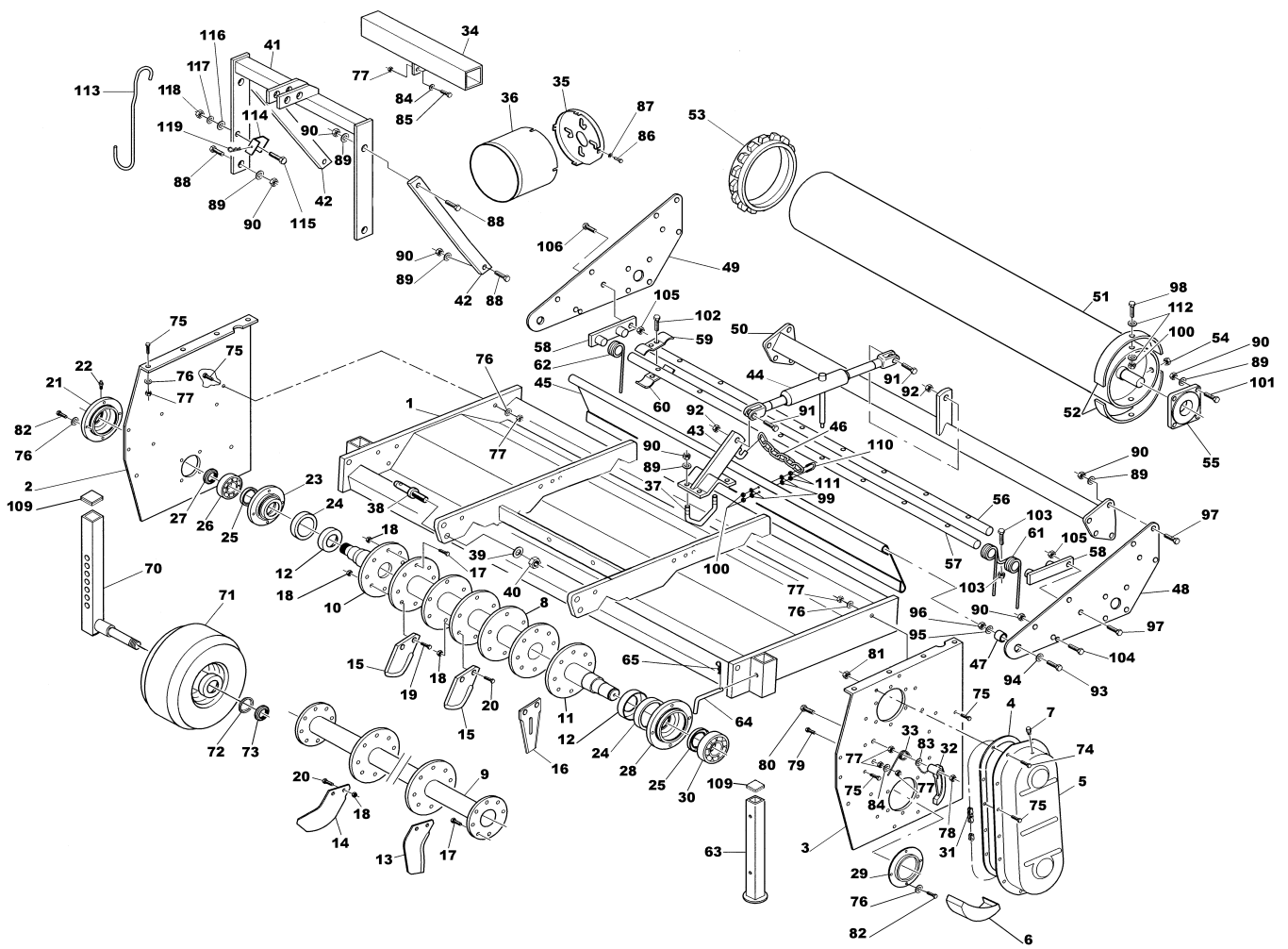

Rotomec: 'Green-Rite 125-145-165'

N.	COD.	DESCRIZIONE	DESCRIPTION	DESCRIPTION	BESCHREIBUNG	N.
28	0084105	Supporto sinistro completo	Complete left support	Palier gauche complet	Linke komplette Auflage	1
29	0034122	Coperchiella esterna sinistra	Left outer cover	Couvercle externe gauche	Linker Außendeckel	1
30	0001061	Cuscinetto 6307	Bearing 6307	Roulement 6307	Lager 6307	1
31	0034141	Catena ASA 80Sx36 v.125,145	Chain ASA 80Sx36 v.125,145	Chaîne ASA 80Sx36 v.125,145	Kette ASA 80Sx36 v.125,145	1
	0134141	Catena ASA 80HEx36 v.165	Chain ASA 80HEx36 v.165	Chaîne ASA 80HEx36 v.165	Kette ASA 80HEx36 v.165	1
32	0030148	Tendicatena	Chain tensioner	Cliquet	Kettenspanner	1
33	0030158	Molla	Spring	Ressort	Feder	1
34	0084154	Protezione v.145	Protection v.145	Protection v.145	Schutz v.145	1
	0184154	Protezione v.165	Protection v.165	Protection v.165	Schutz v.165	1
	0084158	Protezione v.125	Protection v.125	Protection v.125	Schutz v.125	1
	0184158	Protezione v.145 dal 09/2002	Protection v.145 since 09/2002	Protection v.145 depuis 09/2002	Schutz v.145 ab 09/2002	1
	0284158	Protezione v.165 dal 09/2002	Protection v.165 since 09/2002	Protection v.165 depuis 09/2002	Schutz v.165 ab 09/2002	1
35	0011201	Supporto protezione	Protection support	Palier protection	Schutzabdeckungsauflage	1
36	0011207	Protezione cardano	Shaft protection	Protection arbre	Kardangelenschutz	1
37	0011253	Cavalotto	U bolt	Barre d'ancrage	Bügelbolzen	2
38	0005550	Spina attacco trattore	Hitch pin	Axe attelage tracteur	Schlepperanschlußstift	2
39	0005351	Rosetta elastica Ø20	Spring washer Ø20	Rondelle élastique Ø20	Sprengring Ø20	2
40	0005542	Dado M20	Nut M20	Ecrou M20	Mutter M20	2
41	0084262	Attacco terzo punto	Three point hitch	Attache 3 ^{ème} point	Ankupplung für oberen Lenker	1
	0084772	Attacco terzo punto dal 09/2002	Three point hitch since 09/2002	Attache 3 ^{ème} point depuis 09/2002	Ankupplung für oberen Lenker ab 09/2002	1
42	0084268	Lama verticale	Top hitch support	Lame verticale	Vertikale Strebe	2
	0084778	Lama verticale dal 09/2002	Top hitch support since 09/2002	Lame verticale depuis 09/2002	Vertikale Strebe ab 09/2002	2
43	0084432	Attacco tenditore	Turnbuckle hitch	Attelage pour tirant	Spannerankupplung	1
	0084436	Attacco tenditore dal 04/2023	Turnbuckle hitch since 04/2023	Attelage pour tirant depuis 04/2023	Spannerankupplung ab 04/2023	1
44	0038773	Tenditore	Turnbuckle	Tirant	Spanner	1
	0084440	Tenditore dal 04/2023 (include perni di attacco)	Turnbuckle since 04/2023 (includes connecting pins)	Tirant depuis 04/2023 (comprends les pivots de fixation)	Spanner ab 04/2023 (Enthält die Ankerstifte)	1
45	0284453	Cofano posteriore v.125	Rear deflector v.125	Capot arrière v.125	Heckhaube v.125	1
	0084452	Cofano posteriore v.125 dal 06/2018	Rear deflector v.125 since 06/2018	Capot arrière v.125 depuis 06/2018	Heckhaube v.125 ab 06/2018	1
	0084453	Cofano posteriore v.145	Rear deflector v.145	Capot arrière v.145	Heckhaube v.145	1
	0184452	Cofano posteriore v.145 dal 06/2018	Rear deflector v.145 since 06/2018	Capot arrière v.145 depuis 06/2018	Heckhaube v.145 ab 06/2018	1
	0184453	Cofano posteriore v.165	Rear deflector v.165	Capot arrière v.165	Heckhaube v.165	1
	0284452	Cofano posteriore v.165 dal 06/2018	Rear deflector v.165 since 06/2018	Capot arrière v.165 depuis 06/2018	Heckhaube v.165 ab 06/2018	1
46	0007257	Catena Ø6	Chain Ø6	Chaîne Ø6	Kette Ø6	1
47	0048470	Distanziale braccio rullo	Roller arm spacer	Entretoise bras rouleau	Distanzstück am Walzenarm	2
48	0048472	Braccio rullo sinistro	Left roller arm	Bras du rouleau gauche	Linker Walzenarm	1
	0084457	Braccio rullo sinistro dal 12/1998	Left roller arm since 12/1998	Bras du rouleau gauche depuis 12/1998	Linker Walzenarm ab 12/1998	1
49	0084458	Braccio rullo destro	Right roller arm	Bras du rouleau droit	Rechter Walzenarm	1
50	0284462	Telaio porta rullo v.125	Rear crossbar v.125	Châssis rouleau v.125	Walzenrahmen v.125	1
	0448481	Telaio porta rullo v.145	Rear crossbar v.145	Châssis rouleau v.145	Walzenrahmen v.145	1
	0084462	Telaio porta rullo v.165	Rear crossbar v.165	Châssis rouleau v.165	Walzenrahmen v.165	1

Rotomec: 'Green-Rite 125-145-165'

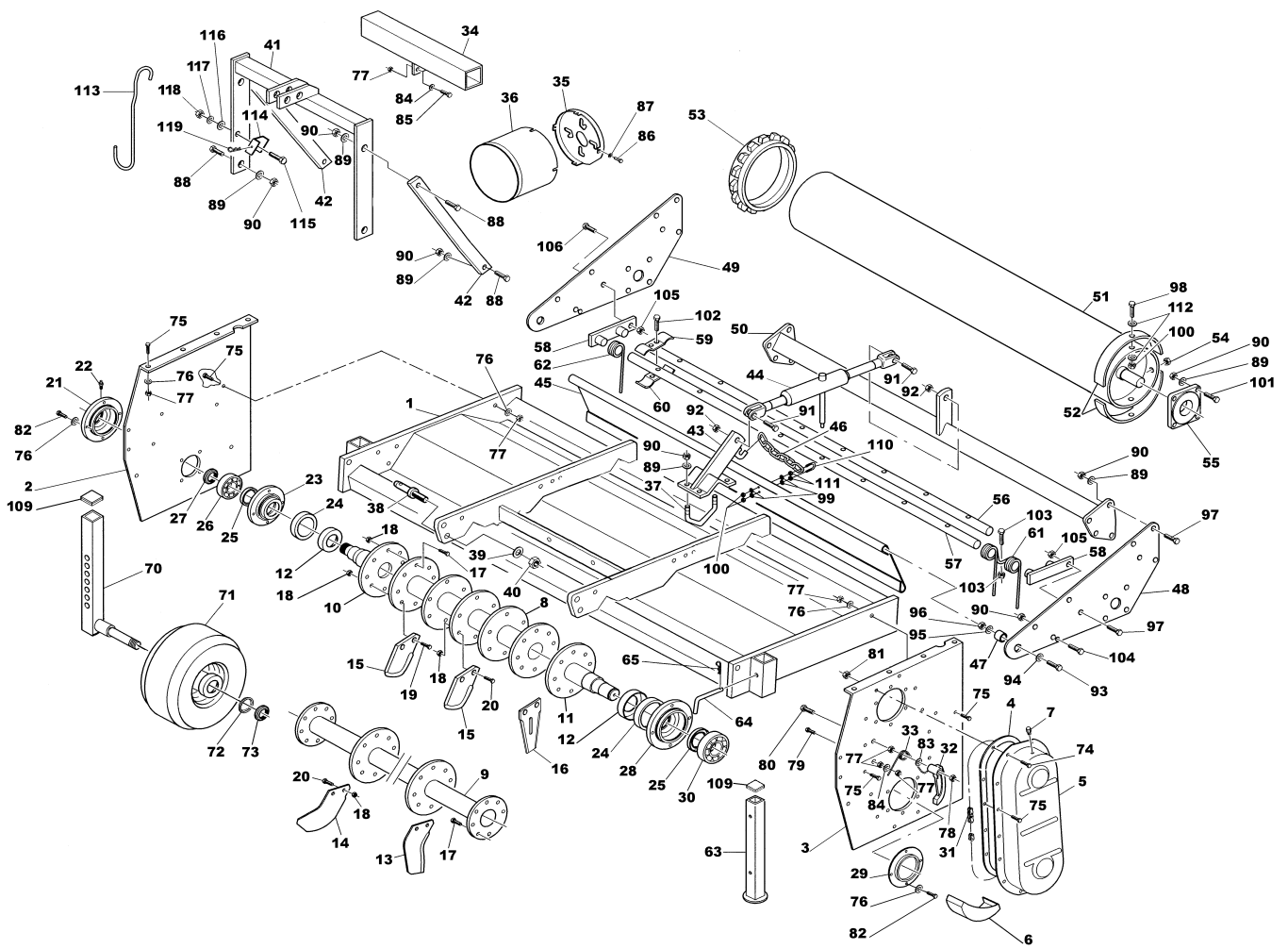

Rotomec: 'Green-Rite 125-145-165'

N.	COD.	DESCRIZIONE	DESCRIPTION	DESCRIPTION	BESCHREIBUNG	N.
51	0284476	Rullo livellatore v.125	Levelling roller v.125	Rouleau niveleur v.125	Nivellierwalze v.125	1
	0448495	Rullo livellatore v.145	Levelling roller v.145	Rouleau niveleur v.145	Nivellierwalze v.145	1
	0084476	Rullo livellatore v.165	Levelling roller v.165	Rouleau niveleur v.165	Nivellierwalze v.165	1
52	0084481	Ritegno anelli dentati v.125	End ring v.125	Arrêt pour anneau v.125	Zahnringzurückhaltung v.125	4
	0046323	Ritegno anelli dentati v.145/165	End ring v.145/165	Arrêt pour anneau v.145/165	Zahnringzurückhaltung v.145/165	4
53	0046322	Anello dentato nylon-fibra di vetro	Corrugated roller ring nylon-fiberglass	Anneau denté	Zahnring	-
	0088589	Anello dentato in ghisa (optional)	Corrugated roller ring in cast iron (optional)	Anneau denté en fonte (option)	Zahnring aus Gusseisen (Zubehör)	-
54	0046325	Tappo	Plastic cap	Bouchon d'huile	Deckel	2
55	0046331	Supporto UCF 207 TF	Support UCF 207 TF	Support UCF 207 TF	Support UCF 207 TF	2
56	0284501	Tubo porta molle v.125	Tickler bar v.125	Tube ressort v.125	Federsträgersrohr v.125	1
	0448521	Tubo porta molle v.145	Tickler bar v.145	Tube ressort v.145	Federsträgersrohr v.145	1
	0084501	Tubo porta molle v.165	Tickler bar v.165	Tube ressort v.165	Federsträgersrohr v.165	1
57	0284505	Tubo porta molle v.125	Tickler bar v.125	Tube ressort v.125	Federsträgersrohr v.125	1
	0448523	Tubo porta molle v.145	Tickler bar v.145	Tube ressort v.145	Federsträgersrohr v.145	1
	0084505	Tubo porta molle v.165	Tickler bar v.165	Tube ressort v.165	Federsträgersrohr v.165	1
58	0046347	Sostegno di testata	Pivot assembly	Soutien de tête	Zylinderkopfauflage	2
59	0046351	Piastra blocca tubi	Locking plate	Plaque de blocage tube	Rohrfeststellplatte	2
60	0146351	Piastra blocca tubi	Locking plate	Plaque de blocage tube	Rohrfeststellplatte	2
61	0046358	Molla	Spring	Ressort	Feder	-
62	0046360	Molla	Spring	Ressort	Feder	1
63	0084613	Piedino di appoggio	Stand	Pied de soutien	Auflagefuß	1
64	0084619	Spina	Hitch pin	Cheville	Zapfen	1
65	0015240	Copiglia a molla Ø3	Cotter pin Ø3	Goupille ressort Ø3	Federsplint Ø3	1
70	0084675	Supporto ruota (optional)	Wheel support (optional)	Support roue (option)	Radaufgabe (Zubehör)	2
	0084670	Supporto ruota dal 11/2006 (optional)	Wheel support since 11/2006 (optional)	Support roue depuis 11/2006 (option)	Radaufgabe ab 11/2006 (Zubehör)	2
71	0084673	Ruota pneumatica (optional)	Air tyre (optional)	Roue pneumatique (option)	Luftreifen (Zubehör)	2
	0067402	Ruota pneumatica dal 11/2006 (optional)	Air tyre since 11/2006 (optional)	Roue pneumatique depuis 11/2006 (option)	Luftreifen ab 11/2006 (Zubehör)	2
72	0006606	Anello di spessoramento Ø25x35x2	Spacer washer Ø25x35x2	Anneau d'épaisseur Ø25x35x2	Distanzring Ø25x35x2	2
73	0006610	Copiglia Ø6x46	Cotter pin Ø6x46	Goupille Ø6x46	Splint Ø6x46	2
	0006698	Dado M25 dal 11/2006	Nut M25 since 11/2006	Ecrou M25 depuis 11/2006	Mutter M25 ab 11/2006	2
74	0006349	Vite TE M10x20	Bolt TE M10x20	Vis TE M10x20	Schraube TE M10x20	10
75	0033176	Vite TE M10x25	Bolt TE M10x25	Vis TE M10x25	Schraube TE M10x25	20
76	0001280	Rosetta elastica Ø10	Spring washer Ø10	Rondelle élastique Ø10	Sprengring Ø10	26
77	0001279	Dado M10	Nut M10	Ecrou M10	Mutter M10	23
78	0030156	Dado M10	Nut M10	Ecrou M10	Mutter M10	1
79	0026329	Vite TE M10x45	Bolt TE M10x45	Vis TE M10x45	Schraube TE M10x45	1
80	0030640	Vite TE M10x65	Bolt TE M10x65	Vis TE M10x65	Schraube TE M10x65	1
81	0090150	Dado M10	Nut M10	Ecrou M10	Mutter M10	14

Rotomec: 'Green-Rite 125-145-165'

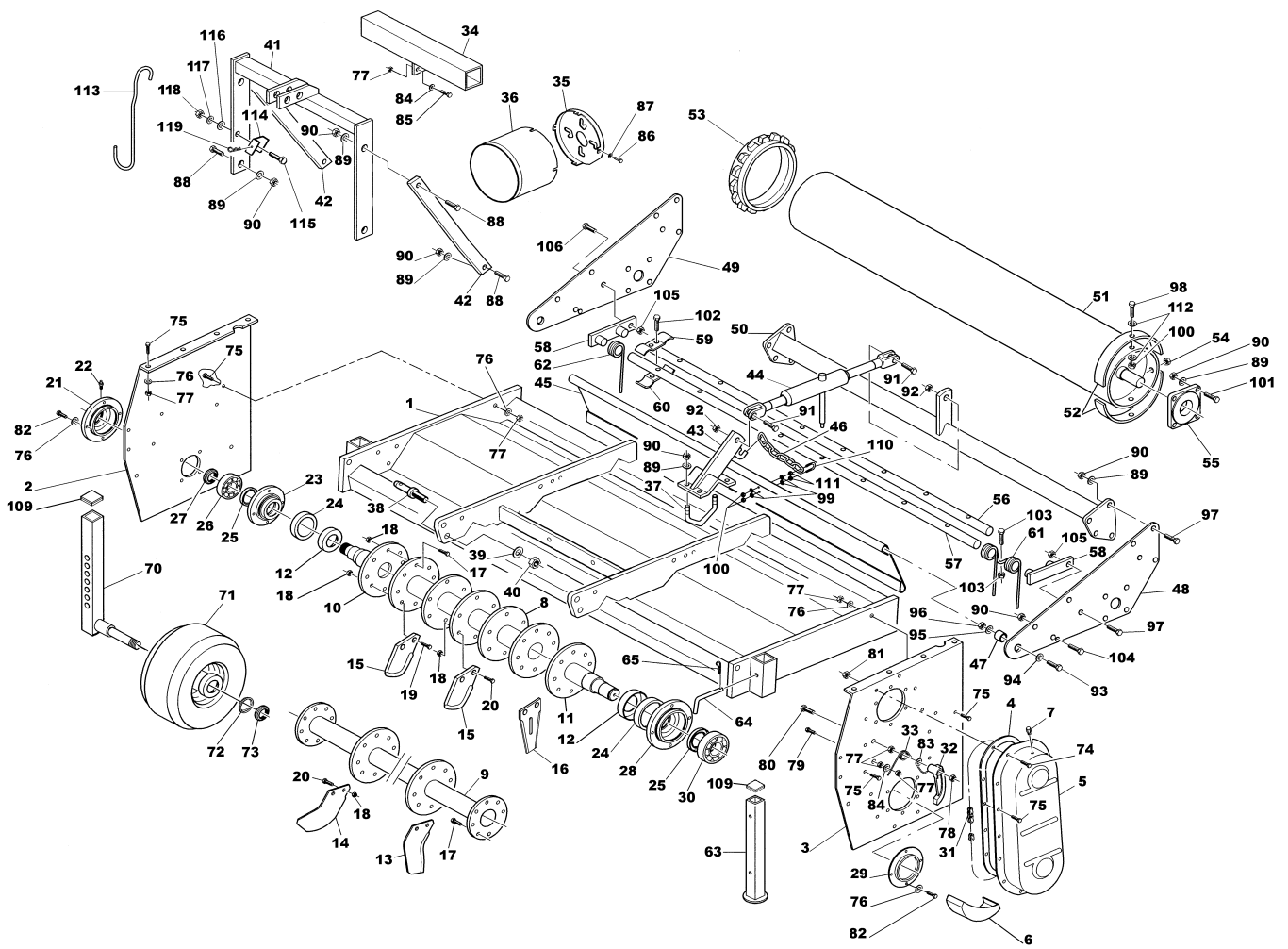

Rotomec: 'Green-Rite 125-145-165'

N.	COD.	DESCRIZIONE	DESCRIPTION	DESCRIPTION	BESCHREIBUNG	N.
82	0001278	Vite TE M10x30	Bolt TE M10x30	Vis TE M10x30	Schraube TE M10x30	8
83	0030157	Rondella piana Ø10	Flat washer Ø10	Rondelle plate Ø10	Flache Scheibe Ø10	1
84	0002034	Rondella piana Ø10	Flat washer Ø10	Rondelle plate Ø10	Flache Scheibe Ø10	3
85	0091281	Vite TE M10x35	Bolt TE M10x35	Vis TE M10x35	Schraube TE M10x35	2
86	0011210	Vite TC M6x12	Bolt TC M6x12	Vis TC M6x12	Schraube TC M6x12	4
87	0011209	Rondella piana Ø6	Flat washer Ø6	Rondelle plate Ø6	Flache Scheibe Ø6	4
88	0007716	Vite TE M12x45	Bolt TE M12x45	Vis TE M12x45	Schraube TE M12x45	6
89	0001077	Rosetta elastica Ø12	Spring washer Ø12	Rondelle élastique Ø12	Sprengring Ø12	26
90	0003038	Dado M12	Nut M12	Ecrou M12	Mutter M12	28
91	0029317	Vite TE M14x50 fino 03/2023	Bolt TE M14x50 until 03/2023	Vis TE M14x50 jusqu'à 03/2023	Schraube TE M14x50 bis 03/2023	2
92	0030358	Dado M14 fino 03/2023	Nut M14 until 03/2023	Ecrou M14 jusqu'à 03/2023	Mutter M14 bis 03/2023	2
93	0037386	Vite TE M18x80	Bolt TE M18x80	Vis TE M18x80	Schraube TE M18x80	2
94	0050049	Rondella piana Ø18	Flat washer Ø18	Rondelle plate Ø18	Flache Scheibe Ø18	2
95	0003366	Rosetta elastica Ø18	Spring washer Ø18	Rondelle élastique Ø18	Sprengring Ø18	2
96	0038370	Dado M18	Nut M18	Ecrou M18	Mutter M18	2
97	0023265	Vite TE M12x40	Bolt TE M12x40	Vis TE M12x40	Schraube TE M12x40	9
98	0046543	Vite TE M8x30	Bolt TE M8x30	Vis TE M8x30	Schraube TE M8x30	8
99	0015230	Rondella piana Ø8	Flat washer Ø8	Rondelle plate Ø8	Flache Scheibe Ø8	4
100	0011328	Dado M8	Nut M8	Ecrou M8	Mutter M8	10
101	0030054	Vite TE M12x50	Bolt TE M12x50	Vis TE M12x50	Schraube TE M12x50	8
102	0008037	Vite TE M8x50	Bolt TE M8x50	Vis TE M8x50	Schraube TE M8x50	4
103	0046362	Vite TTQST M10x50	Bolt TTQST M10x50	Vis TTQST M10x50	Schraube TTQST M10x50	-
104	0003037	Vite TE M12x25	Bolt TE M12x25	Vis TE M12x25	Schraube TE M12x25	2
105	0030064	Dado M12	Nut M12	Ecrou M12	Mutter M12	2
106	0084577	Vite fermo molla	Stop bolt	Vis d'arrêt	Schraube	1
109	0082760	Tappo in plastica	Plastic cap	Bouchon d'huile	Deckel	1
110	0011327	Cavallotto	U bolt	Barre d'ancrage	Bügelbolzen	1
111	0046545	Dado M8	Nut M8	Ecrou M8	Mutter M8	2
112	0014514	Rondella piana Ø8 Fascia larga	Flat washer Ø8 Large band	Rondelle plate Ø8 Bande large	Flache Scheibe Ø8 Breites Band	16
113	0084221	Gancio sostegno cardano solo "CE"	Driveline hook only "CE"	Crochet seulement "CE"	Kardangelenstützhaken nur "CE"	1
114	0022435	Fissaggio per gancio solo "CE"	Hook support only "CE"	Arrêt pour levier seulement "CE"	Fixierung für Haken nur "CE"	1
115	0046543	Vite TE M8x30 solo "CE"	Bolt TE M8x30 only "CE"	Vis TE M8x30 seulement "CE"	Schraube TE M8x30 nur "CE"	1
116	0014514	Rondella piana Ø8 solo "CE"	Flat washer Ø8 only "CE"	Rondelle plate Ø8 seulement "CE"	Flache Scheibe Ø8 nur "CE"	1
117	0003144	Rosetta elastica Ø8 solo "CE"	Washer Ø8 only "CE"	Rondelle élastique Ø8 seulement "CE"	Sprengring Ø8 nur "CE"	1
118	0001806	Dado M8 solo "CE"	Nut M8 only "CE"	Ecrou M8 seulement "CE"	Mutter M8 nur "CE"	1
119	0054422	Copiglia a molla Ø2 solo "CE"	Cotter pin Ø2 only "CE"	Goupille ressort Ø2 seulement "CE"	Federsplint Ø2 nur "CE"	1

Rotomec: 'Green-Rite 125-145-165'

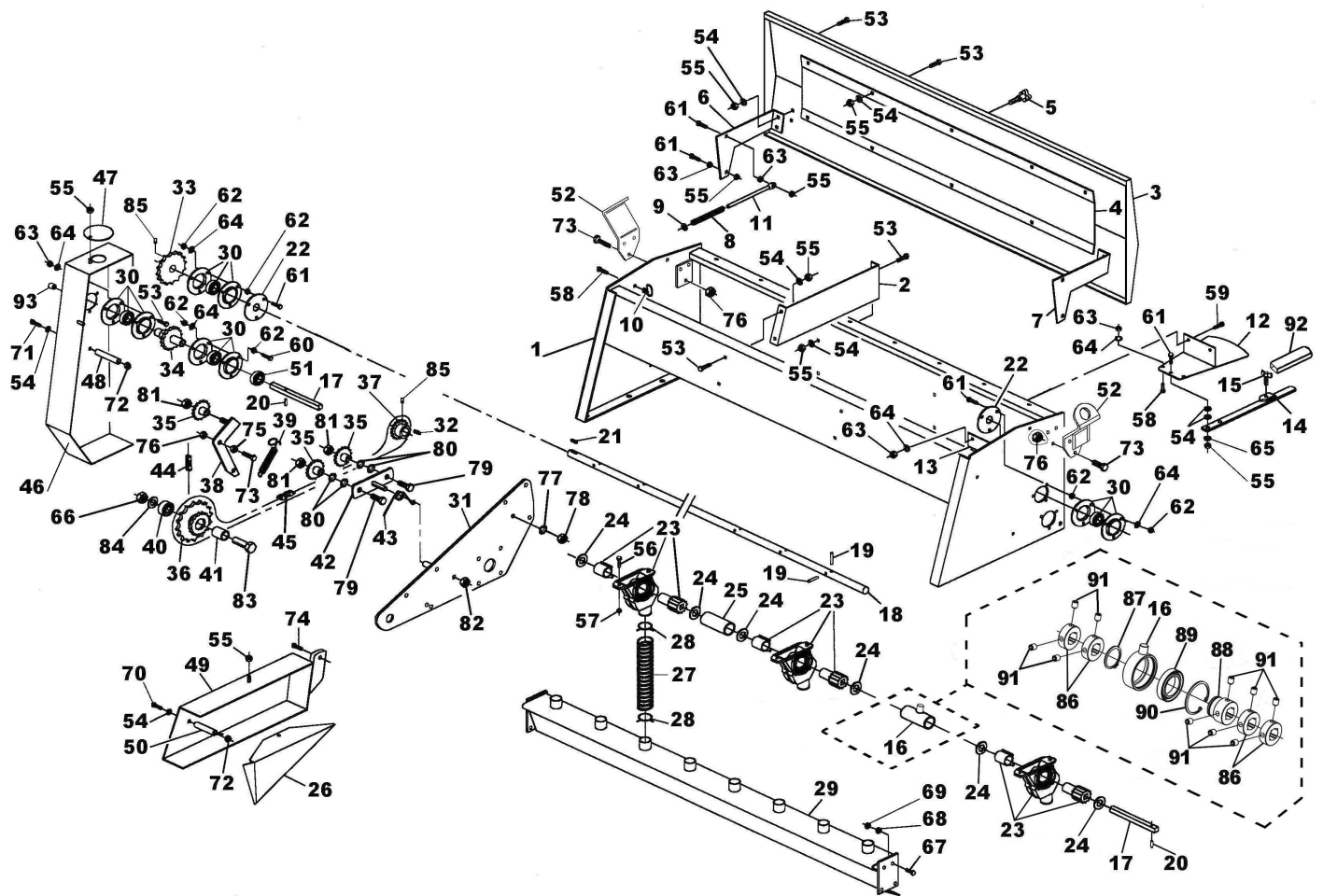

Rotomec: 'Green-Rite 125-145-165'

N.	COD.	DESCRIZIONE	DESCRIPTION	DESCRIPTION	BESCHREIBUNG	N.
1	0284281	Tramoggia v.125	Hopper v.125	Bac v.125	Trichter v.125	1
	0084281	Tramoggia v.145	Hopper v.145	Bac v.145	Trichter v.145	1
	0184281	Tramoggia v.165	Hopper v.165	Bac v.165	Trichter v.165	1
2	0084287	Rinforzo tramoggia	Hopper support	Renfort bac	Trichterverstärkung	2
3	0284292	Coperchio tramoggia v.125	Hopper lid v.125	Couvercle bac v.125	Trichterabdeckung v.125	1
	0084292	Coperchio tramoggia v.145	Hopper lid v.145	Couvercle bac v.145	Trichterabdeckung v.145	1
	0184292	Coperchio tramoggia v.165	Hopper lid v.165	Couvercle bac v.165	Trichterabdeckung v.165	1
4	0284295	Rinforzo coperchio v.125	Cover support v.125	Support couvercle v.125	Deckelverstärkung v.125	1
	0084295	Rinforzo coperchio v.145	Cover support v.145	Support couvercle v.145	Deckelverstärkung v.145	1
	0184295	Rinforzo coperchio v.165	Cover support v.165	Support couvercle v.165	Deckelverstärkung v.165	1
5	0038575	Volantino 10x20	Plastic knob 10x20	Vis fixation couvercle 10x20	Stellrad 10x20	1
	0084310	Volantino dal 05/1999	Plastic knob since 05/1999	Vis fixation couvercle depuis 05/1999	Stellrad ab 05/1999	1
6	0184302	Supporto coperchio destro	Right hopper hinge	Tôle support droite	Rechte Deckelauflage	1
7	0284302	Supporto coperchio sinistro	Left hopper hinge	Tôle support gauche	Linke Deckelauflage	1
8	0046491	Molla fino al 05/1999	Spring until 05/1999	Ressort jusqu'au 05/1999	Feder bis 05/1999	2
9	0084315	Rondella bombata fino al 05/1999	Washer until 05/1999	Rondelle jusqu'au 05/1999	Belligscheibe bis 05/1999	2
10	0046501	Gancio per asta fino al 05/1999	Hook until 05/1999	Crochet pour tige jusqu'au 05/1999	Stangenhaken bis 05/1999	2
11	0046498	Asta ritegno molle fino al 05/1999	Spring rod until 05/1999	Tige block. Ressort jusqu'au 05/1999	Federrückhaltstange bis 05/1999	2
12	0084332	Piastra di regolazione	Calibration plate	Plaque de réglage	Einstellplatte	1
13	0046472	Lamierino fissa piastra	Plate	Tôle de fixation plaque	Plattenbefestigungsblech	1
14	0046561	Leva di regolazione	Calibration handle	Levier de réglage	Einstellhebel	1
15	0046465	Vite M10x20	Bolt M10x20	Vis M10x20	Schraube M10x20	1
16	0048331	Distanziatore fino al 09/2012	Spacer until 09/2012	Entretoise jusqu'au 09/2012	Distanzstück bis 09/2012	1
	0084342	Supporto porta cuscinetto dal 10/2012	Rot. ring support since 10/2012	Soutien pour roulement depuis 10/2012	Lagersupport ab 10/2012	1
17	0084363	Albero scarichi v.125	Drive rod v.125	Arbre de déchargement v. 125	Auslasswelle v.125	1
	0448353	Albero scarichi v.145	Drive rod v.145	Arbre de déchargement v. 145	Auslasswelle v.145	1
	0084365	Albero scarichi v.165	Drive rod v.165	Arbre de déchargement v.165	Auslasswelle v.165	1
18	0284374	Albero scuotitore v. 125	Auger shaft v.125	Arbre mélangeur v.125	Rüttelwelle v.125	1
	0084374	Albero scuotitore v. 145	Auger shaft v.145	Arbre mélangeur v.145	Rüttelwelle v.145	1
	0184374	Albero scuotitore v. 165	Auger shaft v.165	Arbre mélangeur v.165	Rüttelwelle v.165	1
19	0046521	Spina elastica Ø6x60	Roll pin Ø6x60	Goupille élastique Ø6x60	Spannstift Ø6x60	-
20	0006605	Spina elastica Ø6x32	Roll pin Ø6x32	Goupille élastique Ø6x32	Spannstift Ø6x32	2
21	0006639	Linguetta 8x7x25	Key 8x7x25	Clavette 8x7x25	Schlüssel 8x7x25	1
22	0046525	Flangia di chiusura	Closing flange	Plateau du fermeture	Verschlußflansch	2

Rotomec: 'Green-Rite 125-145-165'

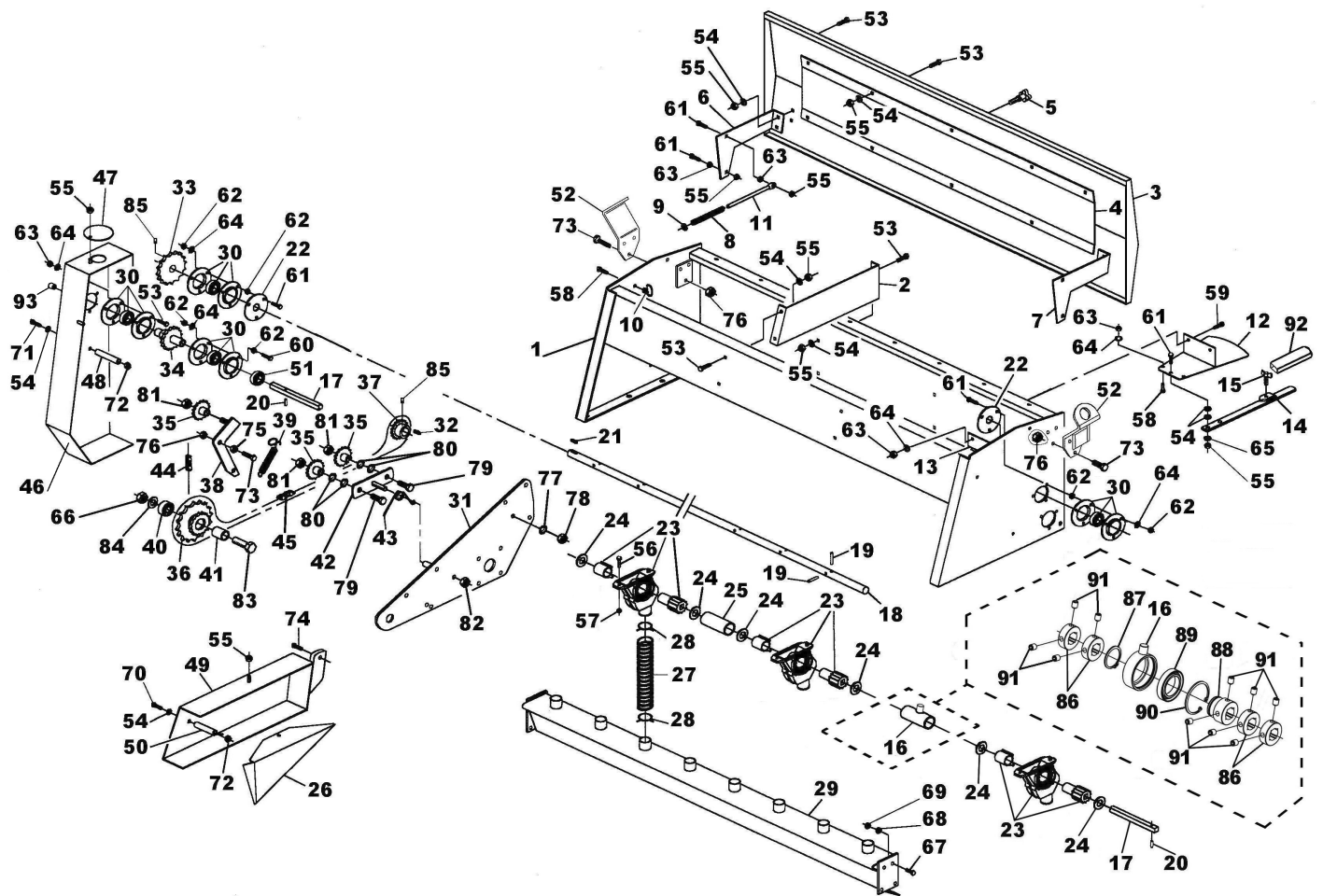

Rotomec: 'Green-Rite 125-145-165'

N.	COD.	DESCRIZIONE	DESCRIPTION	DESCRIPTION	BESCHREIBUNG	N.
23	0046531	Scarico	Seed cup assembly	Déchargement	Auslaß	-
24	0084415	Rondella piana	Flat washer	Rondelle plate	Flache Scheibe	-
25	0048391	Distanziale	Spacer	Entretoise	Distanzstück	-
26	0084610	Lamiera di protezione	Cover plate	Tôle de couverture	Abdeckungsblech	1
27	0084394	Tubo per scarichi cm.21	Fertilizer tube cm.21	Tuyau chargement cm.21	Auslaßrohr cm.21	-
28	0046533	Molla	Spring	Ressort	Feder	-
29	0284422	Supporto scarichi v.125	Discharge support v.125	Support déchargement v.125	Auslaßauflage v.125	1
	0084422	Supporto scarichi v.145	Discharge support v.145	Support déchargement v.145	Auslaßauflage v.145	1
	0184422	Supporto scarichi v.165	Discharge support v.165	Support déchargement v.165	Auslaßauflage v.165	1
30	0046541	Supporto completo	Flange bearing	Palier complet	Komplette Auflage	4
31	0084458	Braccio rullo destro	Right roller arm	Bras du rouleau droit	Rechter Walzenarm	1
32	0006688	Linguetta 8x7x35	Key 8x7x35	Clavette 8x7x35	Schlüssel 8x7x35	1
33	0084527	Pignone dentato Z22	Sprocket pinion Z22	Pignon denté Z22	Zahnritzel Z22	1
34	0084528	Pignone albero scarichi Z15	Sprocket drive rod Z15	Pignon arbre de déchargement Z15	Auslaßwellekegelrad Z15	1
35	0046644	Tendicatena Z14	Idler sprocket Z14	Cliquet Z14	Kettenspanner Z14	3
36	0084552	Ingranaggio di rinvio	Sprocket assembly	Engrenage à renvoi	Zahnrad	1
37	0084582	Pignone dentato Z13	Sprocket pinion Z13	Pignon denté Z13	Zahnritzel Z13	1
38	0084534	Supporto tendicatena	Chain tensioner support	Palier tendeur chaîne	Kettensupport	1
39	0051740	Molla	Spring	Ressort	Feder	1
40	0084556	Cuscinetto 4204	Bearing 4204	Roulement 4204	Lager 4204	1
41	0084559	Distanziale	Spacer	Entretoise	Distanzstück	1
	0087499	Distanziale dal 11/1998	Spacer since 11/1998	Entretoise dès 11/1998	Distanzstück ab 11/1998	1
42	0084572	Supporto tendicatena	Chain adjuster support	Palier tendeur chaîne	Kettenspannersupport	1
43	0084576	Molla	Spring	Ressort	Feder	1
44	0084586	Catena ASA 50x82	Chain ASA 50x82	Chaîne ASA 50x82	Kette ASA 50x82	1
45	0084588	Catena ASA 50x92	Chain ASA 50x92	Chaîne ASA 50x92	Kette ASA 50x92	1
46	0084591	Carter superiore	Upper cover	Carter supérieur	Oberes Carter	1
47	0084596	Coperchiella di chiusura	Closing cover	Cover de fermeture	Abschlußdeckel	1
48	0084599	Distanziale	Spacer	Entretoise	Distanzstück	1
49	0084601	Carter inferiore	Lower cover	Carter inférieur	Untercarter	1
50	0084607	Distanziale	Spacer	Entretoise	Distanzstück	1
51	0084375	Anello di bloccaggio dal 04/2008	Stop ring since 04/2008	Anneau de fissage depuis 04/2008	Haltering ab 04/2008	1
52	0084284	Piastra di sollevamento dal 04/2008	Lift plate since 04/2008	Plaque de soulèvement depuis 04/2008	Abhebungsplatte ab 04/2008	2

Rotomec: 'Green-Rite 125-145-165'

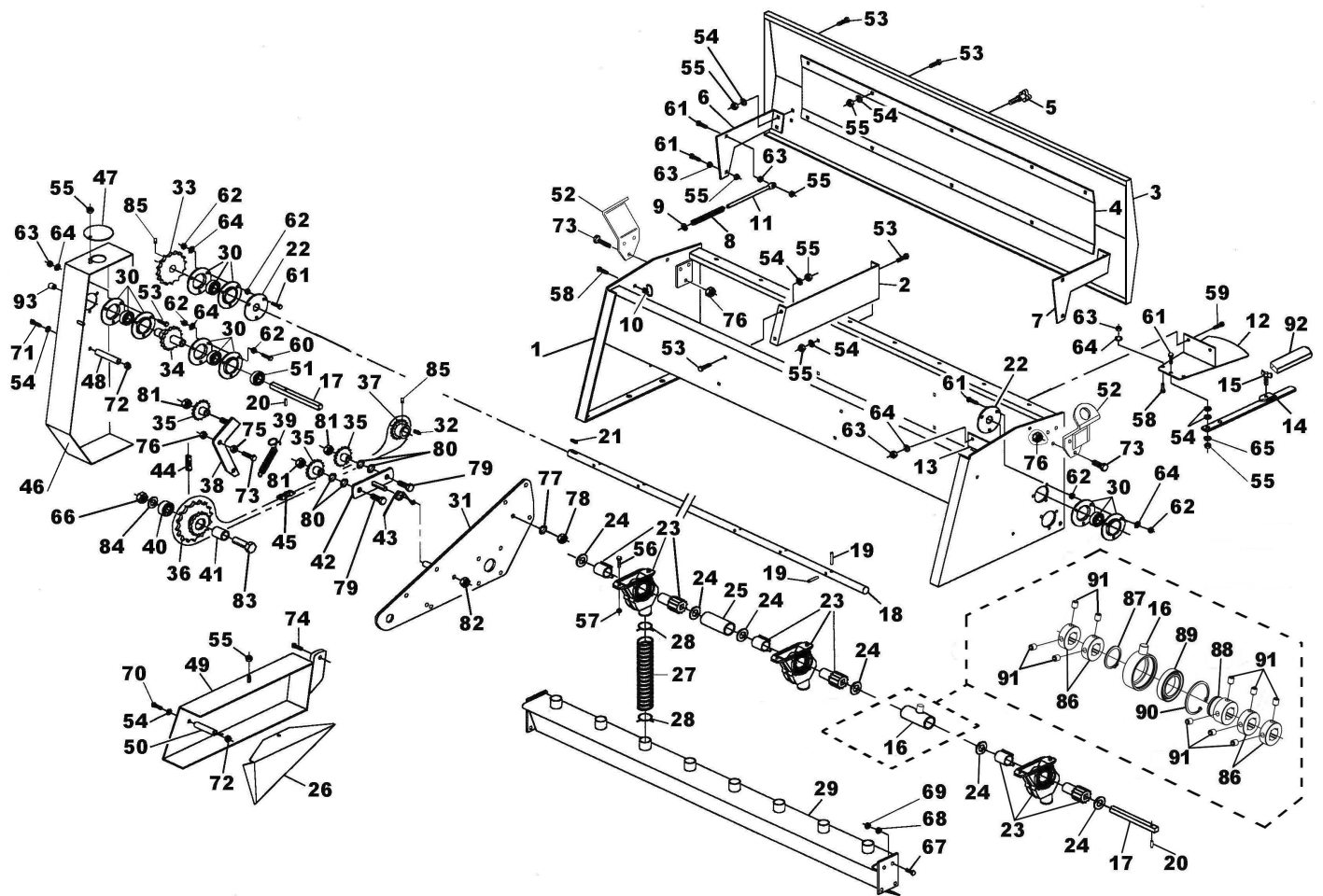

Rotomec: 'Green-Rite 125-145-165'

N.	COD.	DESCRIZIONE	DESCRIPTION	DESCRIPTION	BESCHREIBUNG	N.
53	0084289	Vite TTQST M8x20	Bolt TTQST M8x20	Vis TTQST M8x20	Schraube TTQST M8x20	25
54	0002034	Rondella piana Ø10	Flat washer Ø10	Rondella plate Ø10	Flache Scheibe Ø10	26
55	0091384	Dado autobloccante M8	Locking nut M8	Ecrou autobloquant M8	Mutter M8	27
56	0088748	Vite TTQST M6x20	Bolt TTQST M6x20	Vis TTQST M6x20	Schraube TTQST M6x20	-
57	2003001	Dado M6-1,00	Nut M6-1,00	Ecrou M6-1,00	Mutter M6-1,00	-
58	0046454	Vite TE M8x16	Bolt TE M8x16	Vis TE M8x16	Schraube TE M8x16	2
59	0015012	Vite TE M8x20	Bolt TE M8x20	Vis TE M8x20	Schraube TE M8x20	2
60	0091446	Vite TE M8x25	Bolt TE M8x25	Vis TE M8x25	Schraube TE M8x25	3
61	0046543	Vite TE M8x30	Bolt TE M8x30	Vis TE M8x30	Schraube TE M8x30	9
62	0046545	Dado M8	Nut M8	Ecrou M8	Mutter M8	18
63	0001806	Dado M8	Nut M8	Ecrou M8	Mutter M8	9
64	0003144	Rosetta elastica Ø8	Spring washer Ø8	Rondelle élastique Ø8	Sprengring Ø8	16
65	0015230	Rondella piana Ø8	Flat washer Ø8	Rondelle plate Ø8	Flache Scheibe Ø8	1
66	0005507	Dado M20	Nut M20	Ecrou M20	Mutter M20	1
67	0033176	Vite TE M10x25	Bolt TE M10x25	Vis TE M10x25	Schraube TE M10x25	8
68	0001280	Rosetta elastica Ø10	Spring washer Ø10	Rondelle élastique Ø10	Sprengring Ø10	8
69	0001279	Dado M10	Nut M10	Ecrou M10	Mutter M10	8
70	0015273	Vite TE M10x110	Bolt TE M10x110	Vis TE M10x110	Schraube TE M10x110	1
71	0015263	Vite TE M10x120	Bolt TE M10x120	Vis TE M10x120	Schraube TE M10x120	1
72	0014106	Dado autobloccante M10	Locking nut M10	Ecrou autobloquant M10	Mutter M10	2
73	0007255	Vite TE M12x35	Bolt TE M12x35	Vis TE M12x35	Schraube TE M12x35	7
74	0023265	Vite TE M12x40	Bolt TE M12x40	Vis TE M12x40	Schraube TE M12x40	1
75	0017223	Dado M12	Nut M12	Ecrou M12	Mutter M12	1
76	0030064	Dado M12	Nut M12	Ecrou M12	Mutter M12	7
77	0001077	Rosetta elastica Ø12	Spring washer Ø12	Rondelle élastique Ø12	Sprengring Ø12	1
78	0003038	Dado M12	Nut M12	Ecrou M12	Mutter M12	1
79	0091038	Vite TE M16x50	Bolt TE M16x50	Vis TE M16x50	Schraube TE M16x50	2
80	0008568	Rondella piana Ø16	Flat washer Ø16	Rondelle plate Ø16	Flache Scheibe Ø16	4
81	0005581	Dado M16	Nut M16	Ecrou M16	Mutter M16	3
82	0030358	Dado M14	Nut M14	Ecrou M14	Mutter M14	1
83	0084558	Vite TE M20x90	Bolt TE M20x90	Vis TE M20x90	Schraube TE M20x90	1
84	0046555	Rondella piana Ø20	Flat washer Ø20	Rondelle plate Ø20	Flache Scheibe Ø20	1
85	0084376	Grano M10x10	Set screw M10x10	Goujon M10x10	Stift M10x10	2
86	0084357	Distanziale con foro quadro	Spacer with square hole	Entretoise avec trou carré	Distanzstück mit viereckigem Loch	4
87	0010122	Seeger esterno Ø30	Outer snap ring Ø30	Circlip externe Ø30	Außenseegerring Ø30	1
88	0084352	Perno con foro quadro	Pin with square hole	Axe avec trou carré	Stift mit viereckigem Loch	1
89	0084346	Cuscinetto 61906 2RS	Rot. ring 61906 2RS	Roulement 61906 2RS	Lager 61906 2RS	1
90	0050144	Seeger interno Ø47	Inner snap ring Ø47	Circlip interne Ø47	Innenseegerring Ø47	1
91	0084354	Grano M08x8	Set screw M08x8	Goujon M08x8	Stift M08x8	10
92	0084345	Manopola	Handle	Plate	Handgriff	1
93	0084525	Tappo in gomma Ø22	Rubber cap Ø22	Bouchon Ø22	Deckel Ø22	1

Rotomec: 'Green-Rite 125-145-165', 540 rpm

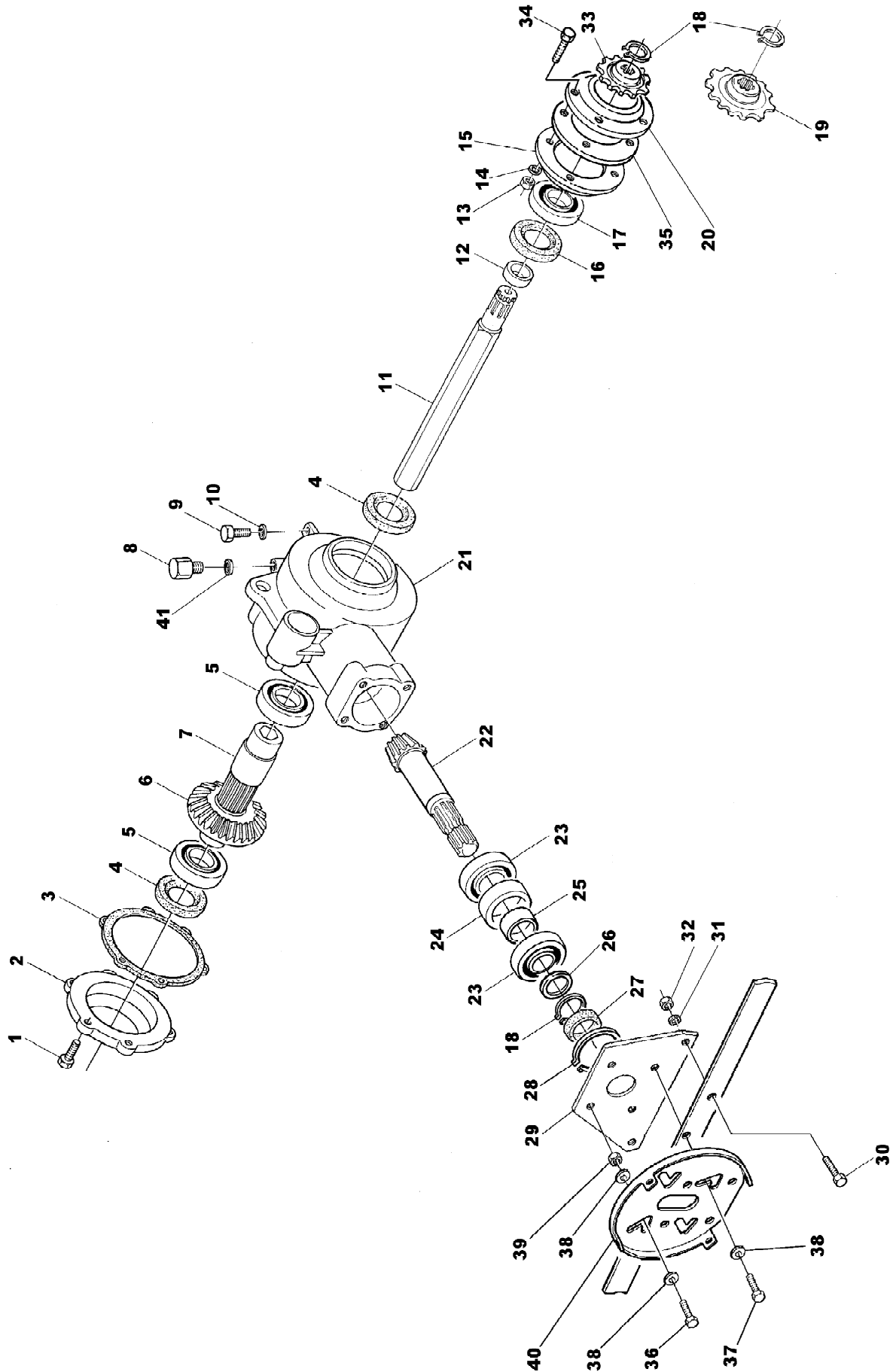

Rotomec: 'Green-Rite 125-145-165', 540 rpm

N.	COD.	DESCRIZIONE	DESCRIPTION	DESCRIPTION	BESCHREIBUNG	N.
1	0006349	Vite TE M10x20	Bolt TE M10x20	Vis TE M10x20	Schraube TE M10x20	6
2	0022178	Coperchiella corona	Gear cover	Couvercle couronne	Kranzhaube	1
3	0022180	Guarnizione 2/10	Gasket 2/10	Joint d'étanchéité 2/10	Dichtung 2/10	-
	0122180	Guarnizione 5/10	Gasket 5/10	Joint d'étanchéité 5/10	Dichtung 5/10	-
4	0002133	Paraolio 50.68.10	Oil seal 50.68.10	Pare-huile 50.68.10	Simmering 50.68.10	2
5	0034178	Cuscinetto 6010	Bearing 6010	Roulement 6010	Lager 6010	2
6	0021176	Corona conica	Ring gear	Couronne conique	Tellerrad	1
7	0034175	Mozzo corona	Shaft coupling	Moyeu couronne	Kranznabe	1
8	0001107A	Sfiatatoio	Breather cap	Bouchon d'huile	Gehäuseentlüfter	1
9	0007716	Vite TE M12x45	Bolt TE M12x45	Vis TE M12x45	Schraube TE M12x45	1
10	0002265	Rondella piana Ø12	Flat washer Ø12	Rondelle plate Ø12	Flache Scheibe Ø12	1
11	0334166	Albero esagonale v.125	Hexagonal shaft v.125	Arbre hexagonal v.125	Sechskantwelle v.125	1
	0434166	Albero esagonale v.145	Hexagonal shaft v.145	Arbre hexagonal v.145	Sechskantwelle v.145	1
	0534166	Albero esagonale v.165	Hexagonal shaft v.165	Arbre hexagonal v.165	Sechskantwelle v.165	1
12	0002049	Distanziale	Spacer	Entretoise	Distanzstück	1
13	0001279	Dado M10	Nut M10	Ecrou M10	Mutter M10	4
14	0001280	Rosetta elastica Ø10	Spring washer Ø10	Rondelle élastique Ø10	Sprengring Ø10	4
15	0030092	Coperchiella	Cover	Couvercle	Deckel	1
16	0034159	Paraolio 45.60.10	Oil seal 45.60.10	Pare-huile 45.60.10	Simmering 45.60.10	1
17	0001061	Cuscinetto 6307	Bearing 6307	Roulement 6307	Lager 6307	1
18	0042122	Seeger esterno Ø35	Outer snap ring Ø35	Circlip externe Ø35	Außenseegerring Ø35	3
19	0034131	Ruota dentata Z14	Sprocket Z14	Roue dentée Z14	Zahnrad Z14	1
20	0034122	Coperchiella esterna sinistra	Left outer cover	Couvercle externe gauche	Linker Außendeckel	1
21	0022170	Scatola ingranaggi	Gearbox	Boîtier	Getriebekasten	1
22	0021177	Pignone conico	Pinion gear	Pignon conique	Kegelrad	1
23	0025332	Cuscinetto 6207	Bearing 6207	Roulement 6207	Lager 6207	2
24	0034197	Distanziale esterno	Outer spacer	Entretoise externe	Außendistanzstück	1
25	0034198	Distanziale interno	Inner spacer	Entretoise interne	Innendistanzstück	1
26	0034196	Anello di spessoramento Ø35x45x2.5	Spacer washer Ø35x45x2.5	Anneau d'épaisseur Ø35x45x2.5	Distanzstück Ø35x45x2.5	1
27	0030211	Paraolio 35.72.10	Oil seal 35.72.10	Pare-huile 35.72.10	Simmering 35.72.10	1
28	0025329	Seeger interno Ø72	Inner snap ring Ø72	Circlip interne Ø72	Innenseegerring Ø72	1
29	0030218	Lamiera anteriore scatola	Gearbox front cover	Couvercle antérieur boîtier	Gehäusevorderblech	1
30	0007255	Vite TE M12x35	Bolt TE M12x35	Vis Te M12x35	Schraube TE M12x35	2
31	0001077	Rosetta elastica Ø12	Spring washer Ø12	Rondelle élastique Ø12	Sprengring Ø12	2
32	0003038	Dado M12	Nut M12	Ecrou M12	Mutter M12	2
33	0034134	Ruota dentata Z11	Sprocket Z11	Roue dentée Z11	Zahnrad Z11	1
34	0001278	Vite TE M10x30	Bolt TE M10x30	Vis TE M10x30	Schraube TE M10x30	4
35	0034121	Disco forato	Disk with holes	Entretoise	Bohrscheibe	1
36	0091281	Vite TE M10x35	Bolt TE M10x35	Vis TE M10x35	Schraube TE M10x35	2
37	0001278	Vite TE M10x30	Bolt TE M10x30	Vis TE M10x30	Schraube TE M10x30	2
38	0030157	Rondella piana Ø10	Flat washer Ø10	Rondelle plate Ø10	Flache Scheibe Ø10	6
39	0001106	Dado M12	Nut M12	Ecrou M12	Mutter M12	2
40	0011201	Supporto protezione	Protection support	Palier protection	Schutzabdeckungsauflage	1
41	0006691	Guarnizione	Gasket	Joint d'étanchéité	Dichtung	1
	0500606	Gruppo scatola	Gearbox	Boîtier	Gehäusegruppe	-

Rotomec: 'Green-Rite 125-145-165'

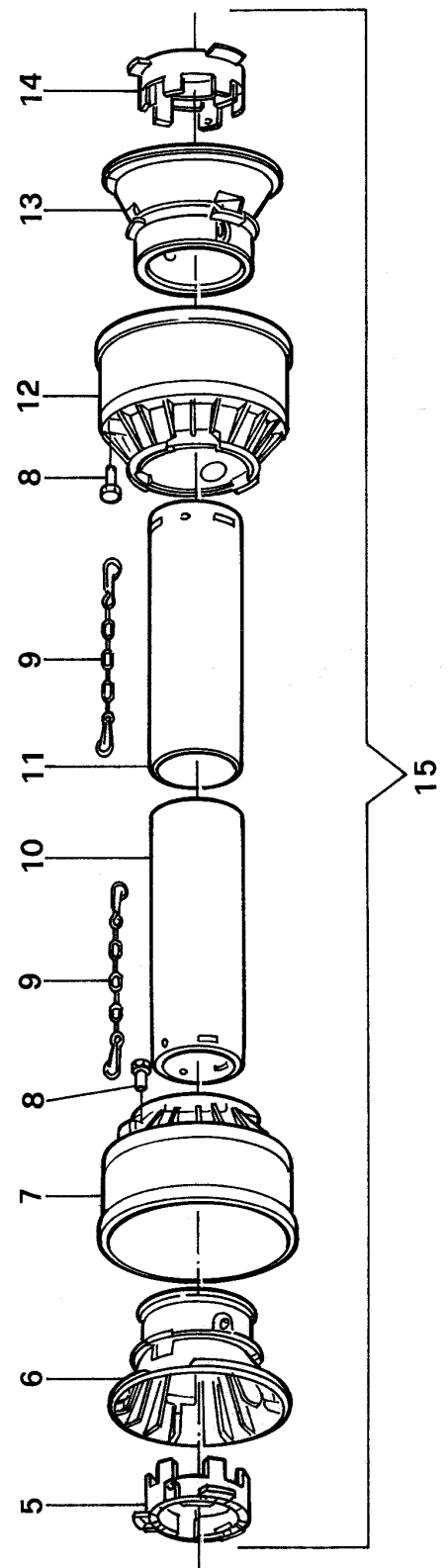
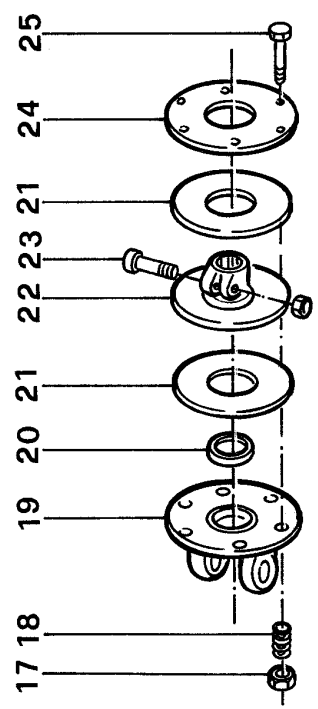
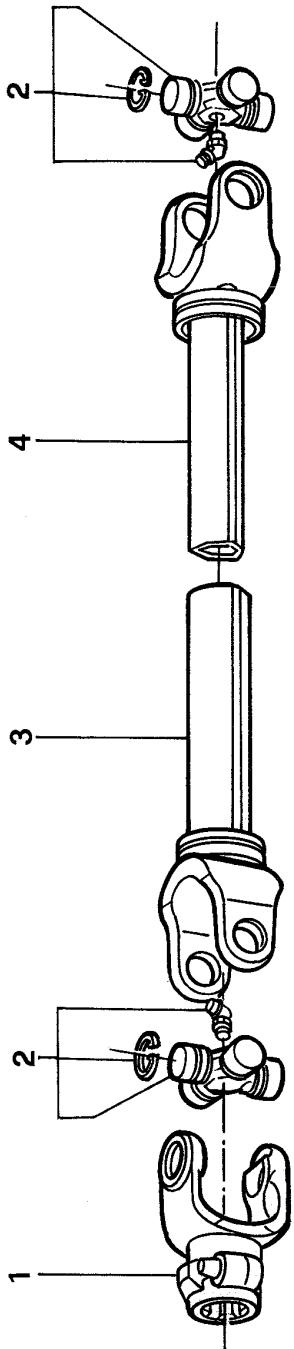

Rotomec: 'Green-Rite 125-145-165'

N.	COD.	DESCRIZIONE	DESCRIPTION	DESCRIPTION	BESCHREIBUNG	N.
1	1023010C	Forcella P.D.F.	PTO Yoke	Fourche P.D.F.	Aufsteckgabel	1
2	1003020C	Crociera	Cross & Bearing	Croisillon	Kreuzgelenk	2
3	1943043NC	Tubo esterno	Outer tube	Tube externe	Außenrohr	1
4	1953045NC	Tubo interno	Inner tube	Tube interne	Innenrohr	1
5	1784210C	Anello tubo esterno fino 04/2008	Outer locking ring until 04/2008	Anneau tube externe jusqu'à 04/2008	Außenrohrhrring bis 04/2008	1
6	1784201C	Controcuffia tubo esterno fino 04/2008	Outer tube rigid cone until 04/2008	Contre coiffe tube externe jusqu'à 04/2008	Außenrohrgegentopf bis 04/2008	1
7	1784203C	Cuffia esterna fino 04/2008	Outer cone until 04/2008	Coiffe externe jusqu'à 04/2008	Außenschutztopf bis 04/2008	1
8	1784212C	Spina di bloccaggio fino 04/2008	Pin until 04/2008	Goupille jusqu'à 04/2008	Haltestift bis 04/2008	2
9	1006065C	Catenella	Chain	Chaîne	Kette	2
10	1773041C	Tubo protezione esterna	Female tube shield	Tube protection femelle	Außenschutzrohr	1
11	1872041C	Tubo protezione interna	Male tube shield	Tube protection mâle	Innenschutzrohr	1
12	1784207C	Cuffia esterna fino 04/2008	Outer cone until 04/2008	Coiffe externe jusqu'à 04/2008	Außenschutztopf bis 04/2008	1
13	1784202C	Controcuffia tubo interno fino 04/2008	Inner tube rigid cone until 04/2008	Contre coiffe tube interne jusqu'à 04/2008	Innenrohrgegentopf bis 04/2008	1
14	1784211C	Anello tubo interno fino 04/2008	Inner locking ring until 04/2008	Anneau tube interne jusqu'à 04/2008	Innenrohrhrring bis 04/2008	1
15	9493300C	Protezione completa fino 04/2008	Complete shielding until 04/2008	Protection complète jusqu'à 04/2008	Kompletter Schutz bis 04/2008	1
16	1333030C	Frizione completa	Complete slip clutch	Embrayage complet	Komplette Kupplung	1
17	0014106	Dado autobloccante D.10	Locking nut D.10	Ecrou autobloquant D.10	Mutter D.10	8
18	1215012C	Molla	Spring	Ressort	Feder	8
19	014017E	Forcella frizione	Yoke-slip clutch	Fourche	Kupplungsgabel	1
20	015020E	Bronzina	Bushing	Coussinet en bronze	Bronzelager	1
21	014019E	Ferodo	Friction disc	Disque friction	Bremsbelag	2
22	014018E	Corpo frizione	Body-slip clutch	Corps friction	Kupplungskörper	1
23	000502E	Vite e dado 12x65	Bolt and nut 12x65	Vis et écrou 12x65	Schraube und Mutter 12x65	1
24	014020E	Flangia frizione	Outer flange	Plaque	Kupplungsflansch	1
25	0015236	Vite TE 10x80	Bolt TE 10x80	Vis TE 10x80	Schraube TE 10x80	8
	0500431	Cardano fino 04/2008	PTO shaft until 04/2008	Arbre à cardan jusqu'à 04/2008	Kardangelenk bis 04/2008	-

Rotomec: 'Green-Rite 125-145-165'

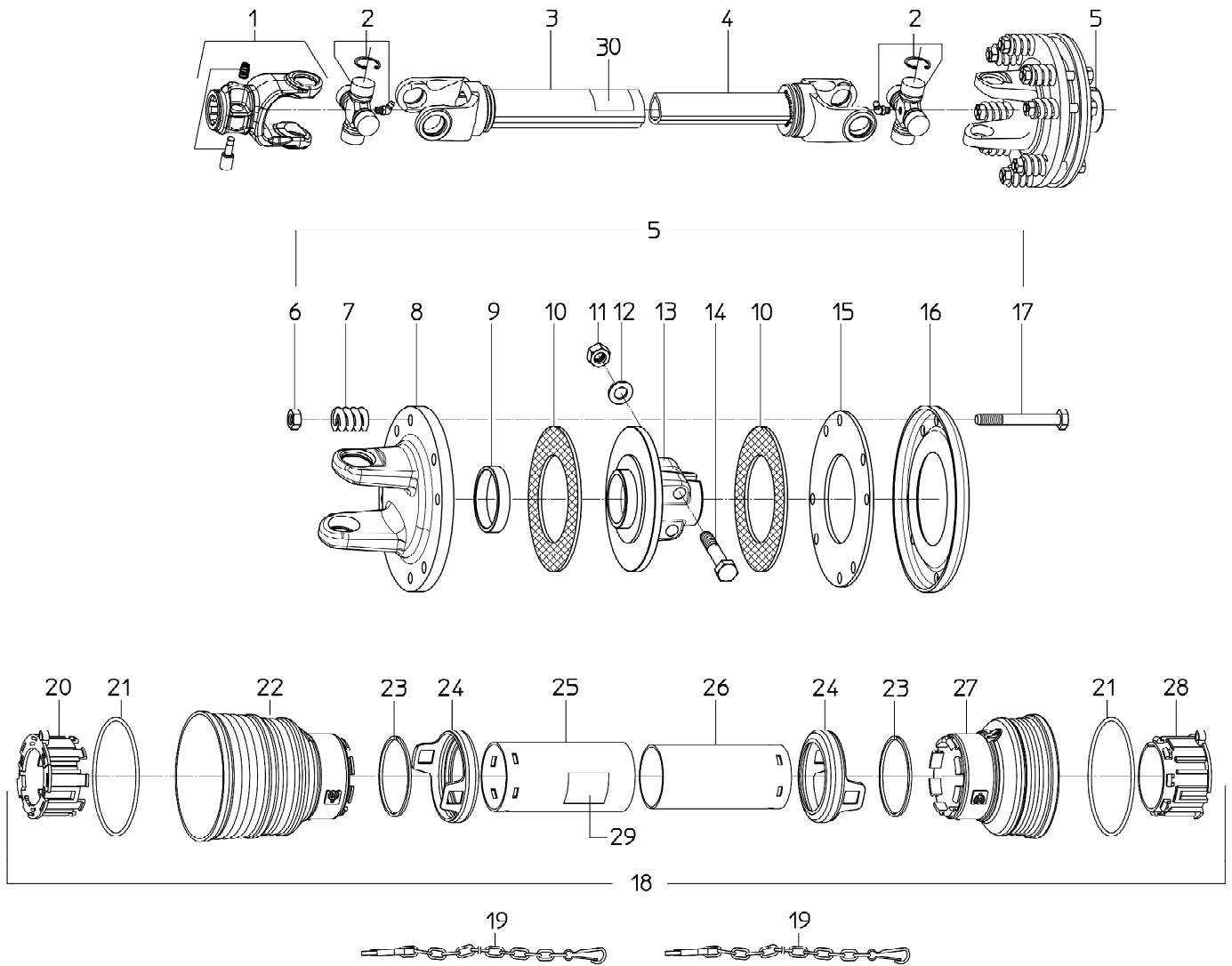

Rotomec: 'Green-Rite 125-145-165'

N.	COD.	DESCRIZIONE	DESCRIPTION	DESCRIPTION	BESCHREIBUNG	N.
1	1023010C	Forcella P.D.F.	PTO Yoke	Fourche P.D.F.	Aufsteckgabel	1
2	1003020C	Crociera	Cross & Bearing	Croisillon	Kreuzgelenk	2
3	1943043NC	Tubo esterno fino 03/2020	Outer tube until 03/2020	Tube externe jusqu'à 03/2020	Außenrohr bis 03/2020	1
4	1953045NC	Tubo interno fino 03/2020	Inner tube until 03/2020	Tube interne jusqu'à 03/2020	Innenrohr bis 03/2020	1
5	1333030C	Frizione completa	Complete slip clutch	Embrayage complet	Komplette Kupplung	1
6	0030156	Dado M10	Nut M10	Ecrou M10	Mutter M10	8
7	1215012C	Molla	Spring	Ressort	Feder	8
8	1703130C	Forcella frizione	Yoke-slip clutch	Fourche	Kupplungsgabel	1
9	1704017C	Bronzina	Bushing	Coussinet en bronze	Bronzelager	1
10	1804000C	Ferodo	Friction disc	Disque friction	Bremsbelag	2
11	0001075	Dado M12	Nut M12	Ecrou M12	Mutter M12	1
12	0001077	Rosetta elastica Ø12	Washer Ø12	Rondelle élastique Ø12	Sprengring Ø12	1
13	1704016C	Corpo frizione	Body-slip clutch	Corps friction	Kupplungskörper	1
14	0034270	Vite TE M12x65	Bolt TE M12x65	Vis TE M12x65	Schraube TE M12x65	1
15	1134008C	Disco interno	Inner disc	Disque interne	Innenscheibe	1
16	1134007C	Flangia frizione	Outer flange	Plaque	Kupplungsflansch	1
17	0015232	Vite TE M10x75	Bolt TE M10x75	Vis TE M10x75	Schraube TE M10x75	8
18	96SE4041C	Protezione completa	Complete shielding	Protection complète	Kompletter Schutz	1
19	1006065C	Catenella	Chain	Chaîne	Kette	2
20	1784710C	Anello tubo esterno	Outer locking ring	Anneau tube externe	Außenrohrring	1
21	1211733C	Anello di rinforzo	Stiffening ring	Anneau de renfort	Verstärkungsring	2
22	1781723C	Cuffia esterna	Outer cone	Coiffe externe	Außenschutztopf	1
23	1211735C	Anello di bloccaggio	Stop ring	Anneau de fissage	Haltering	2
24	1881709C	Manicotto di sicurezza	Safety sleeve	Manchon de sécurité	Sicherheitsmuffe	2
25	1773041C	Tubo protezione esterna	Female tube shield	Tube protection femelle	Außenschutzrohr	1
26	1872041C	Tubo protezione interna	Male tube shield	Tube protection mâle	Innenschutzrohr	1
27	1781721C	Cuffia esterna	Outer cone	Coiffe externe	Außenschutztopf	1
28	1784711C	Anello tubo interno	Inner locking ring	Anneau tube interne	Innenrohrring	1
29	1140010C	Adesivo esterno solo "CE"	Outer decal only "CE"	Autocollant extérieur seulement "CE"	Außerer Aufkleber nur "CE"	1
	950-463B	Adesivo esterno solo "USA"	Outer decal only "USA"	Autocollant extérieur seulement "USA"	Außerer Aufkleber nur "USA"	1
30	1140011C	Adesivo interno solo "CE"	Inner decal only "CE"	Autocollant intérieur seulement "CE"	Innerer Aufkleber nur "CE"	1
	950-464B	Adesivo interno solo "USA"	Inner decal only "USA"	Autocollant intérieur seulement "USA"	Innerer Aufkleber nur "USA"	1
	0500431	Cardano solo "CE" dal 05/2008 fino 03/2020	PTO shaft only "CE" since 05/2008 until 03/2020	Arbre à cardan seulement "CE" depuis 05/2008 jusqu'à 03/2020	Kardangelenk nur "CE" ab 05/2008 bis 03/2020	-
	0500408	Cardano solo "USA" dal 05/2008 fino 03/2020	PTO shaft only "USA" since 05/2008 until 03/2020	Arbre à cardan seulement "USA" depuis 05/2008 jusqu'à 03/2020	Kardangelenk nur "USA" ab 05/2008 bis 03/2020	-

Rotomec: 'Green-Rite 125-145-165'

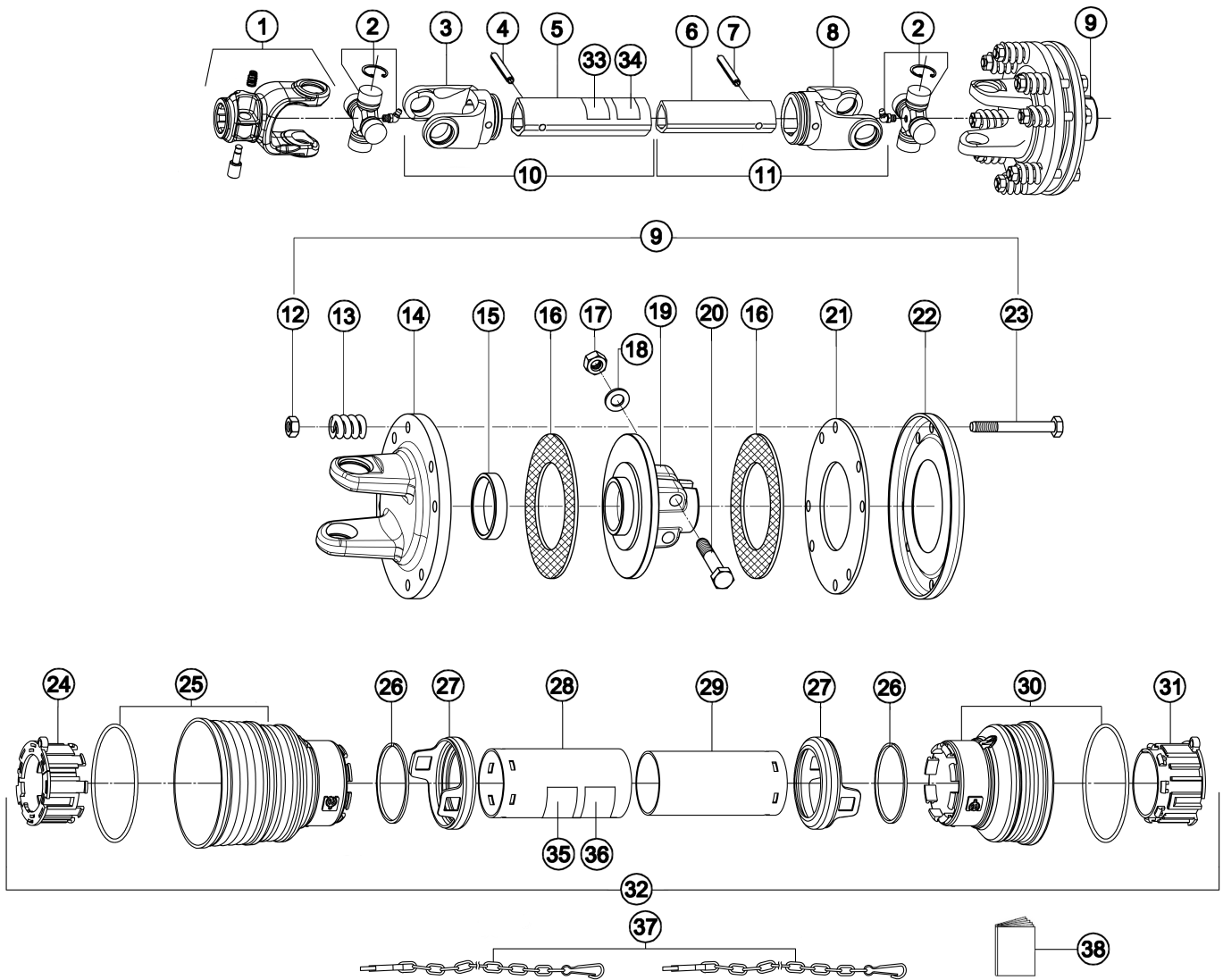

Rotomec: 'Green-Rite 125-145-165'

N.	COD.	DESCRIZIONE	DESCRIPTION	DESCRIPTION	BESCHREIBUNG	N.
1	1023010C	Forcella P.D.F.	PTO Yoke	Fourche P.D.F.	Aufsteckgabel	1
2	1003020C	Crociera	Cross & Bearing	Croisillon	Kreuzgelenk	2
3	1703027C	Forcella tubo esterno da 04/2020	Female yoke since 04/2020	Fourche femelle depuis 04/2020	Außenrohrgabel ab 04/2020	1
4	0018044	Spina elastica Ø8x60 da 04/2020	Roll pin Ø8x60 since 04/2020	Goupille élastique Ø8x60 depuis 04/2020	Spannstift Ø8x60 ab 04/2020	1
5	1524047C	Tubo esterno da 04/2020	Outer tube since 04/2020	Tube externe depuis 04/2020	Außenrohr ab 04/2020	1
6	1523047C	Tubo interno da 04/2020	Inner tube since 04/2020	Tube interne depuis 04/2020	Innenrohr ab 04/2020	1
7	0008679	Spina elastica Ø8x55 da 04/2020	Roll pin Ø8x55 since 04/2020	Goupille élastique Ø8x55 depuis 04/2020	Spannstift Ø8x55 ab 04/2020	1
8	1703029C	Forcella tubo interno da 04/2020	Male yoke since 04/2020	Fourche mâle depuis 04/2020	Innenrohrgabel ab 04/2020	1
9	1333030C	Frizione completa	Complete slip clutch	Embrayage complet	Komplette Kupplung	1
10	1903047NC	Tubo esterno completo	Outer tube	Tube externe	Außenrohr	1
11	1913047NC	Tubo interno completo	Inner tube	Tube interne	Innenrohr	1
12	0030156	Dado M10	Nut M10	Ecrou M10	Mutter M10	8
13	1215012C	Molla	Spring	Ressort	Feder	8
14	1703130C	Forcella frizione	Yoke-slip clutch	Fourche	Kupplungsgabel	1
15	1704017C	Bronzina	Bushing	Coussinet en bronze	Bronzelager	1
16	1804000C	Ferodo	Friction disc	Disque friction	Bremsbelag	2
17	0001075	Dado M12	Nut M12	Ecrou M12	Mutter M12	1
18	0001077	Rosetta elastica Ø12	Washer Ø12	Rondelle élastique Ø12	Sprengring Ø12	1
19	1704016C	Corpo frizione	Body-slip clutch	Corps friction	Kupplungskörper	1
20	0034270	Vite TE M12x65	Bolt TE M12x65	Vis TE M12x65	Schraube TE M12x65	1
21	1134008C	Disco interno	Inner disc	Disque interne	Innenscheibe	1
22	1134007C	Flangia frizione	Outer flange	Plaque	Kupplungsflansch	1
23	0015232	Vite TE M10x75	Bolt TE M10x75	Vis TE M10x75	Schraube TE M10x75	8
24	1784710C	Anello tubo esterno	Outer locking ring	Anneau tube externe	Außenrohrring	1
25	1881703C	Cuffia esterna standard	Standard outer cone	Coiffe externe standard	Serienmäßiger Außenschutztopf	1
26	1211735C	Anello di bloccaggio	Stop ring	Anneau de fissage	Haltering	2
27	1881709C	Manicotto di sicurezza	Safety sleeve	Manchon de sécurité	Sicherheitsmuffe	2
28	1873039C	Tubo protezione esterna	Outer tube shield	Tube protection externe	Außenschutzrohr	1
29	1872039C	Tubo protezione interna	Inner tube shield	Tube protection interne	Innenschutzrohr	1
30	1881701C	Cuffia esterna	Outer cone	Coiffe externe	Außenschutztopf	1
31	1784711C	Anello tubo interno	Inner locking ring	Anneau tube interne	Innenrohrring	1
32	97SE4039C	Protezione completa	Complete shield	Protection complète	Kompletter Schutz	1
33	950-464B	Adesivo interno USA	Inner decal USA	Autocollant intérieur USA	Innerer Aufkleber USA	1
34	1140011C	Adesivo interno CE	Inner decal CE	Autocollant intérieur CE	Innerer Aufkleber CE	1
35	950-463B	Adesivo esterno USA	Outer decal USA	Autocollant extérieur USA	Außerer Aufkleber USA	1
36	1140010C	Adesivo esterno CE	Outer decal CE	Autocollant extérieur CE	Außerer Aufkleber CE	1
37	1006065C	Catenella	Chain	Chaîne	Kette	2
38	1140910AC	Manuale di istruzioni	Operator's manual	Livret d'entretien et d'utilisation	Bedienungs- und Wartungsanleitung	1
	0500053	Cardano dal 04/2020	PTO shaft since 04/2020	Arbre à cardan depuis 04/2020	Kardangelenk ab 04/2020	-

Rotomec: 'Green-Rite 125-145-165'

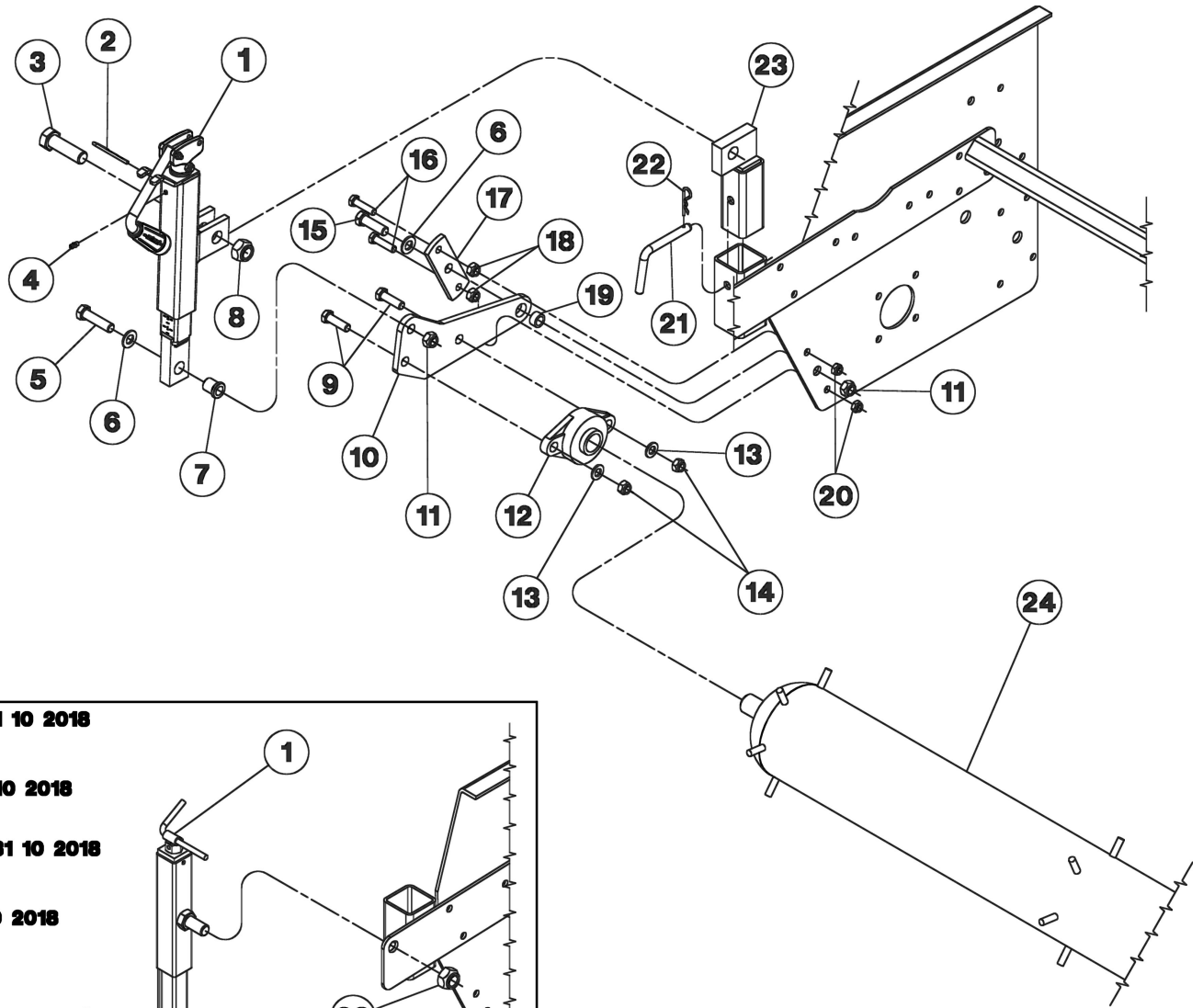

Fino a 31 10 2018

Until 31 10 2018

Jusqu'au 31 10 2018

Bis 31 10 2018

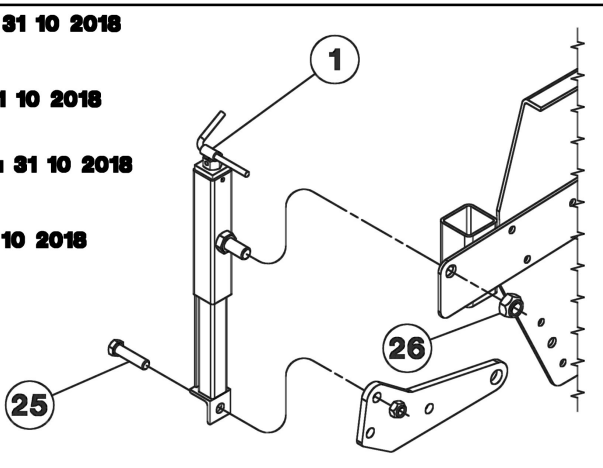

Rotomec: 'Green-Rite 125-145-165'

N.	COD.	DESCRIZIONE	DESCRIPTION	DESCRIPTION	BESCHREIBUNG	N.
1	0084645	Vite regolazione completa fino a 31 10 2018	Complete register screw until 31 10 2018	Vis de réglage complet jusqu'au 31 10 2018	Komplette Schraube bis 31 10 2018	2
	0084640	Vite regolazione completa dal 01 11 2018	Complete register screw since 01 11 2018	Vis de réglage complet depuis 01 11 2018	Komplette Schraube ab 01 11 2018	2
2	0091507	Copiglia Ø4	Cotter pin Ø4	Goupille ressort Ø4	Federsplint Ø4	2
3	0008576	Vite TE M20x65	Bolt TE M20x65	Vis TE M20x65	Schraube M20x65	2
4	0051129	Ingrassatore M6-1.00	Grease fitting M6-1.00	Graisseur M6-1.00	Schmiernippel M6-1.00	2
5	0032371	Vite TE M14x55	Bolt TE M14x55	Vis TE M14x55	Schraube TE M14x55	2
6	0091435	Rondella piana Ø14	Flat washer Ø14	Rondelle plate Ø14	Flache Scheibe Ø14	4
7	0084641	Boccola	Bushing	Douille	Büchse	2
8	0005507	Dado M20	Nut M20	Ecrou M20	Mutter M20	2
9	0023265	Vite TE M12x40	Bolt TE M12x40	Vis TE M12x40	Schraube TE M12x40	4
10	0084631	Braccio rullo	Roller arm	Bras du rouleau	Walzenarm	2
11	0030358	Dado M14	Nut M14	Ecrou M14	Mutter M14	4
12	0037514	Supporto UCFL 206 TF	Support UCFL 206 TF	Support UCFL 206 TF	Support UCFL 206 TF	2
13	0002265	Rondella piana Ø12	Flat washer Ø12	Rondelle plate Ø12	Flache Scheibe Ø12	4
14	0030064	Dado M12	Nut M12	Ecrou M12	Mutter M12	4
15	0001018	Vite TE M14x45	Bolt TE M14x45	Vis TE M14x45	Schraube TE M14x45	2
16	0038614	Vite TE M10x40	Bolt TE M10x40	Vis TE M10x40	Schraube TE M10x40	4
17	0084633	Piastrina di fermo	Plate	Plaque	Feststellplatte	2
18	0003038	Dado M12	Nut M12	Ecrou M12	Mutter M12	4
19	0084642	Tubo cerniera	Spacer	Entretoise	Distanzstück	2
20	0030156	Dado M10	Nut M10	Ecrou M10	Mutter M10	4
21	0084619	Spina	Hitch pin	Cheville	Zapfen	2
22	0015240	Copiglia a molla Ø3	Cotter pin Ø3	Goupille ressort Ø3	Federsplint Ø3	2
23	0084661	Tubo di attacco	Hitch tube	Tube de attelage	Rohranschub	2
24	0284622	Rullo anteriore v.125	Front roller v.125	Rouleau antérieur v.125	Vordere Walze v.125	1
	0084622	Rullo anteriore v.145	Front roller v.145	Rouleau antérieur v.145	Vordere Walze v.145	1
	0184622	Rullo anteriore v.165	Front roller v.165	Rouleau antérieur v.165	Vordere Walze v.165	1
25	0001526	Vite TE M14x35	Bolt TE M14x35	Vis TE M14x35	Schraube TE M14x35	2
26	0017506	Dado M18	Nut M18	Ecrou M18	Mutter M18	2
	0099648	Set rullo anteriore v.125	Front Roller v.125	Rouleau antérieur v.125	Vordere Walze v.125	-
	0099516	Set rullo anteriore v.145	Front Roller v.145	Rouleau antérieur v.145	Vordere Walze v.145	-
	0099563	Set rullo anteriore v.165	Front Roller v.165	Rouleau antérieur v.165	Vordere Walze v.165	-

Rotomec: 'Green-Rite 125-145-165'

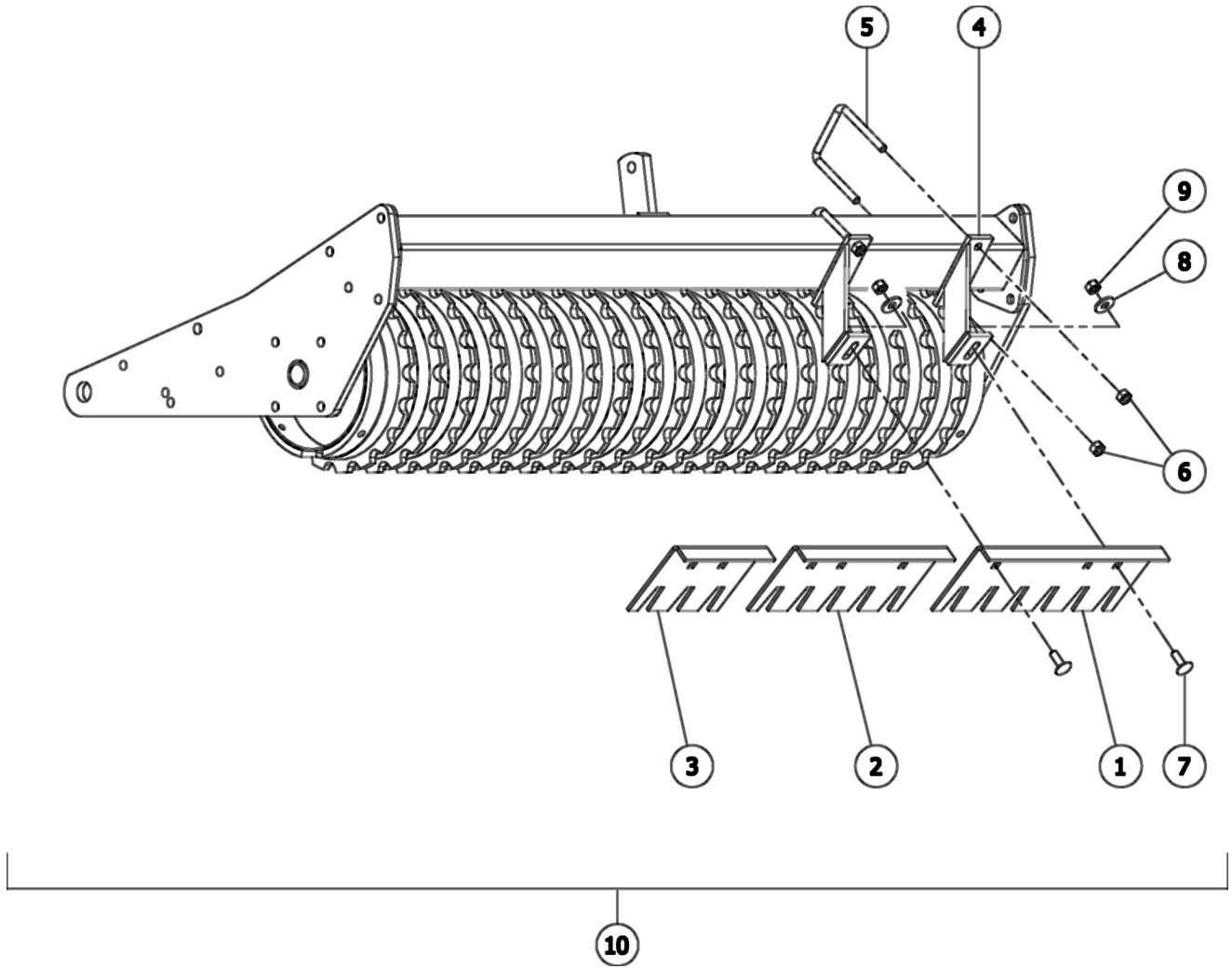

Rotomec: 'Green-Rite 125-145-165'

N.	COD.	DESCRIZIONE	DESCRIPTION	DESCRIPTION	BESCHREIBUNG	N.
1	0084683	Lamiera raschiarullo v.125,145,165	Roller scraper plate v.125,145,165	Tôle racleur rouleau v.125,145,165	Walzenabstreichersblech v.125,145,165	-
	0184683	Lamiera raschiarullo v.125,145,165 dal 01/2019	Roller scraper plate v.125,145,165 since 01/2019	Tôle racleur rouleau v.125,145,165 depuis 01/2019	Walzenabstreichersblech v.125,145,165 ab 01/2019	-
2	0284683	Lamiera raschiarullo v.125,145,165 dal 01/2019	Roller scraper plate v.125,145,165 since 01/2019	Tôle racleur rouleau v.125,145,165 depuis 01/2019	Walzenabstreichersblech v.125,145,165 ab 01/2019	-
3	0084682	Lamiera raschiarullo laterale v.125	Side roller scraper plate v.125	Tôle racleur rouleau latérale v.125	Seitenwalzenabstreichersblech h v.125	1
	0084684	Lamiera raschiarullo laterale v.165	Side roller scraper plate v.165	Tôle racleur rouleau latérale v.165	Seitenwalzenabstreichersblech h v.165	1
4	0084685	Supporto raschiarullo	Roller scraper support	Palier racleur rouleau	Walzenabstreicherssupport	-
5	0084693	Cavallotto	U bolt	Barre d'ancrage	Bügelbolzen	-
6	0030156	Dado M10	Nut M10	Ecrou M10	Mutter M10	-
7	0001036	Vite TTQST 10x30	Bolt TTQST 10x30	Vis TTQST 10x30	Schraube TTQST 10x30	-
8	0030157	Rondella piana Ø10	Flat washer Ø10	Rondelle plate Ø10	Flache Scheibe Ø10	-
9	0014106	Dado autobloccante M10	Locking nut M10	Ecrou autobloquant M10	Mutter M10	-
10	0099650	Set raschiarullo v.125 fino 03/2020	Roller scraper v.125 until 03/2020	Racleur rouleau v.125 jusqu'à 03/2020	Walzenabstreicher v.125 bis 03/2020	-
	0099539	Set raschiarullo v.145 fino 03/2020	Roller scraper v.145 until 03/2020	Racleur rouleau v.145 jusqu'à 03/2020	Walzenabstreicher v.145 bis 03/2020	-
	0099565	Set raschiarullo v.165 fino 03/2020	Roller scraper v.165 until 03/2020	Racleur rouleau v.165 jusqu'à 03/2020	Walzenabstreicher v.165 bis 03/2020	-

Rotomec: 'Green-Rite 125-145-165'

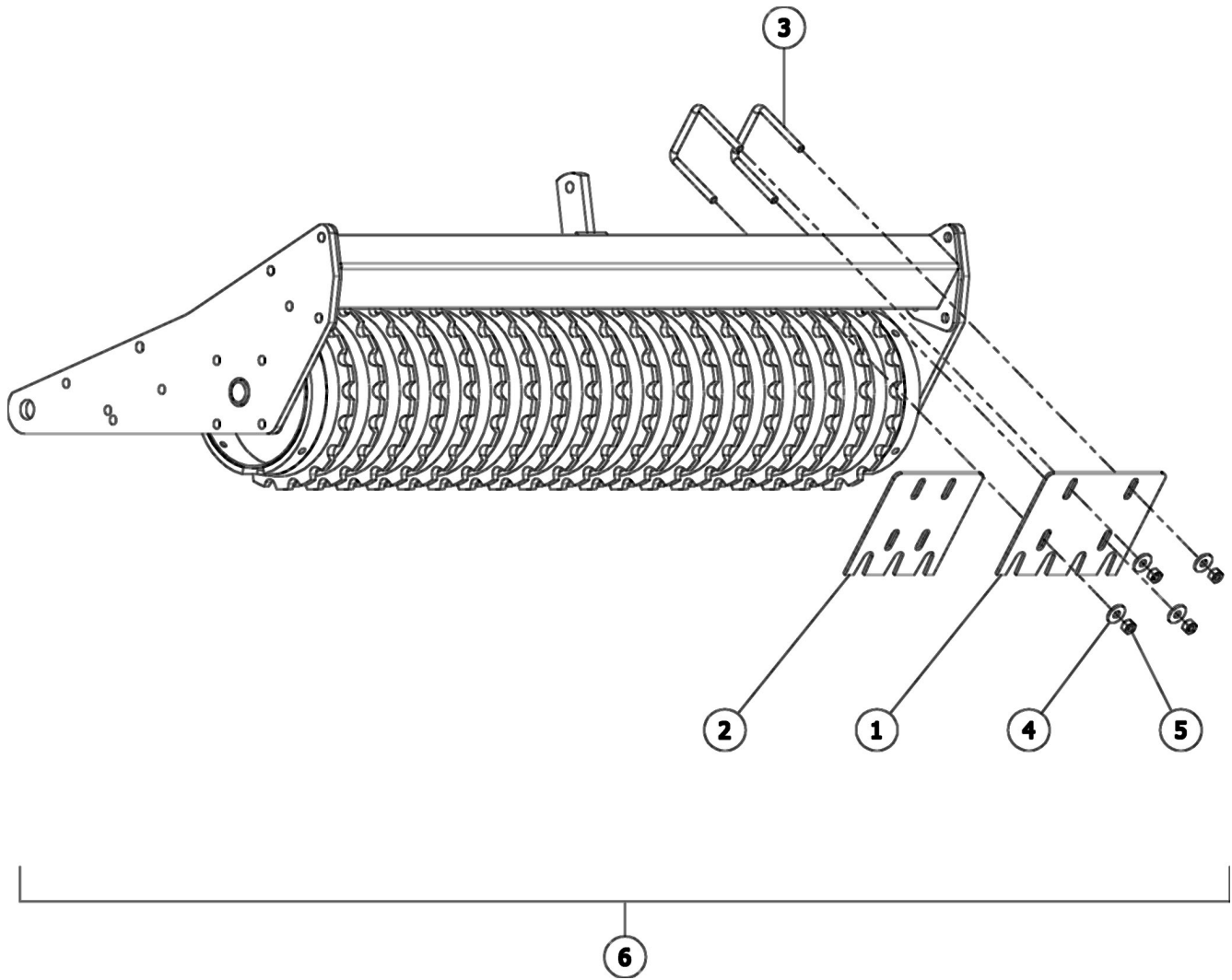

Rotomec: 'Green-Rite 125-145-165'

N.	COD.	DESCRIZIONE	DESCRIPTION	DESCRIPTION	BESCHREIBUNG	N.
1	0084690	Lamiera raschiarullo a 4 gole v.125,145,165	Roller scraper plate , 4 ring v.125,145,165	Tôle racleur rouleau v.125,145,165	Walzenabstreichersblech v.125,145,165	4
2	0084689	Lamiera raschiarullo a 3 gole v.125	Roller scraper plate , 3 ring v.125	Tôle racleur rouleau v.125	Walzenabstreichersblech v.125	1
	0084689	Lamiera raschiarullo a 3 gole v.145	Roller scraper plate , 3 ring v.145	Tôle racleur rouleau v.145	Walzenabstreichersblech v.145	2
	0084689	Lamiera raschiarullo a 3 gole v.165	Roller scraper plate , 3 ring v.165	Tôle racleur rouleau v.165	Walzenabstreichersblech v.165	3
3	0084693	Cavallotto v.125	U bolt v.125	Barre d'ancrage v.125	Bügelbolzen v.125	10
	0084693	Cavallotto v.145	U bolt v.145	Barre d'ancrage v.145	Bügelbolzen v.145	12
	0084693	Cavallotto v.165	U bolt v.165	Barre d'ancrage v.165	Bügelbolzen v.165	14
4	0030157	Rondella piana Ø10 v.125	Flat washer Ø10 v.125	Rondelle plate Ø10 v.125	Flache Scheibe Ø10 v.125	20
	0030157	Rondella piana Ø10 v.145	Flat washer Ø10 v.145	Rondelle plate Ø10 v.145	Flache Scheibe Ø10 v.145	24
	0030157	Rondella piana Ø10 v.165	Flat washer Ø10 v.165	Rondelle plate Ø10 v.165	Flache Scheibe Ø10 v.165	28
5	0014106	Dado autobloccante M10 v.125	Locking nut M10 v.125	Ecrou autobloquant M10 v.125	Mutter M10 v.125	20
	0014106	Dado autobloccante M10 v.145	Locking nut M10 v.145	Ecrou autobloquant M10 v.145	Mutter M10 v.145	24
	0014106	Dado autobloccante M10 v.165	Locking nut M10 v.165	Ecrou autobloquant M10 v.165	Mutter M10 v.165	28
6	0099189	Set raschiarullo v.125 dal 04/2020	Roller scraper v.125 since 04/2020	Racleur rouleau v.125 depuis 04/2020	Walzenabstreicher v.125 ab 04/2020	-
	0099190	Set raschiarullo v.145 dal 04/2020	Roller scraper v.145 since 04/2020	Racleur rouleau v.145 depuis 04/2020	Walzenabstreicher v.145 ab 04/2020	-
	0099191	Set raschiarullo v.165 dal 04/2020	Roller scraper v.165 since 04/2020	Racleur rouleau v.165 depuis 04/2020	Walzenabstreicher v.165 ab 04/2020	-

Rotomec: 'Green-Rite 125-145-165'

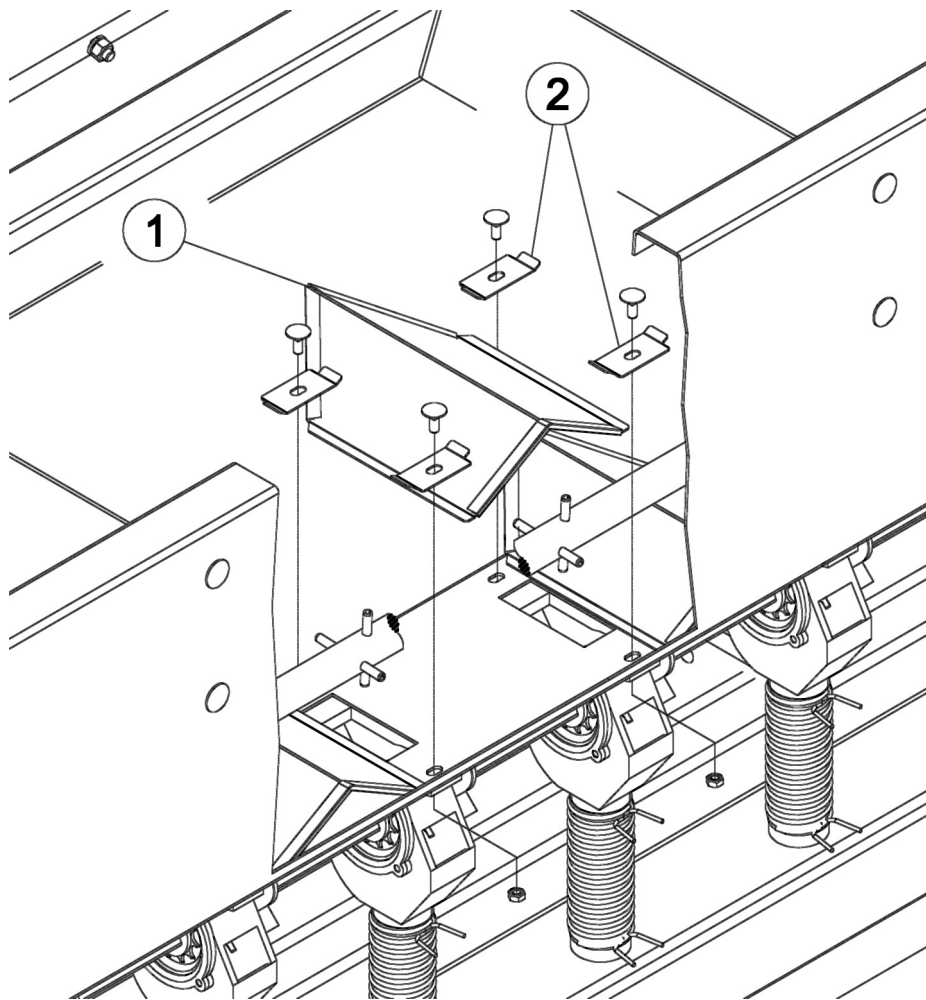

Rotomec: 'Green-Rite 125-145-165'

N.	COD.	DESCRIZIONE	DESCRIPTION	DESCRIPTION	BESCHREIBUNG	N.
1	0088740	Lamiera convogliaseme v.125	Conveyor plate v.125	Tôle convoyeur v.125	Konveyorsplatte v.125	6
	0088740	Lamiera convogliaseme v.145	Conveyor plate v.145	Tôle convoyeur v.145	Konveyorsplatte v.145	7
	0088740	Lamiera convogliaseme v.165	Conveyor plate v.165	Tôle convoyeur v.165	Konveyorsplatte v.165	8
2	0088742	Piastrina di fissaggio v.125	Attachment plate v.125	Plaque de fixation v.125	Befestigungsplatte v.125	14
	0088742	Piastrina di fissaggio v.145	Attachment plate v.145	Plaque de fixation v.145	Befestigungsplatte v.145	16
	0088742	Piastrina di fissaggio v.165	Attachment plate v.165	Plaque de fixation v.165	Befestigungsplatte v.165	18
	0099139	Set completo lamiera convogliaseme v.125	Conveyor kit v.125	Set complet tôle convoyeur v.125	Konveyorsplattensystem komplett v.125	1
	0099140	Set completo lamiera convogliaseme v.145	Conveyor kit v.145	Set complet tôle convoyeur v.145	Konveyorsplattensystem komplett v.145	1
	0099141	Set completo lamiera convogliaseme v.165	Conveyor kit v.165	Set complet tôle convoyeur v.165	Konveyorsplattensystem komplett v.165	1

