

# ROTOMECH

## HOP '300-500'

Spandiconcime portato

3 pt. fertilizer spreader

Epandeur d'engrais à disque, porté

Einscheiben-Düngerstreuer

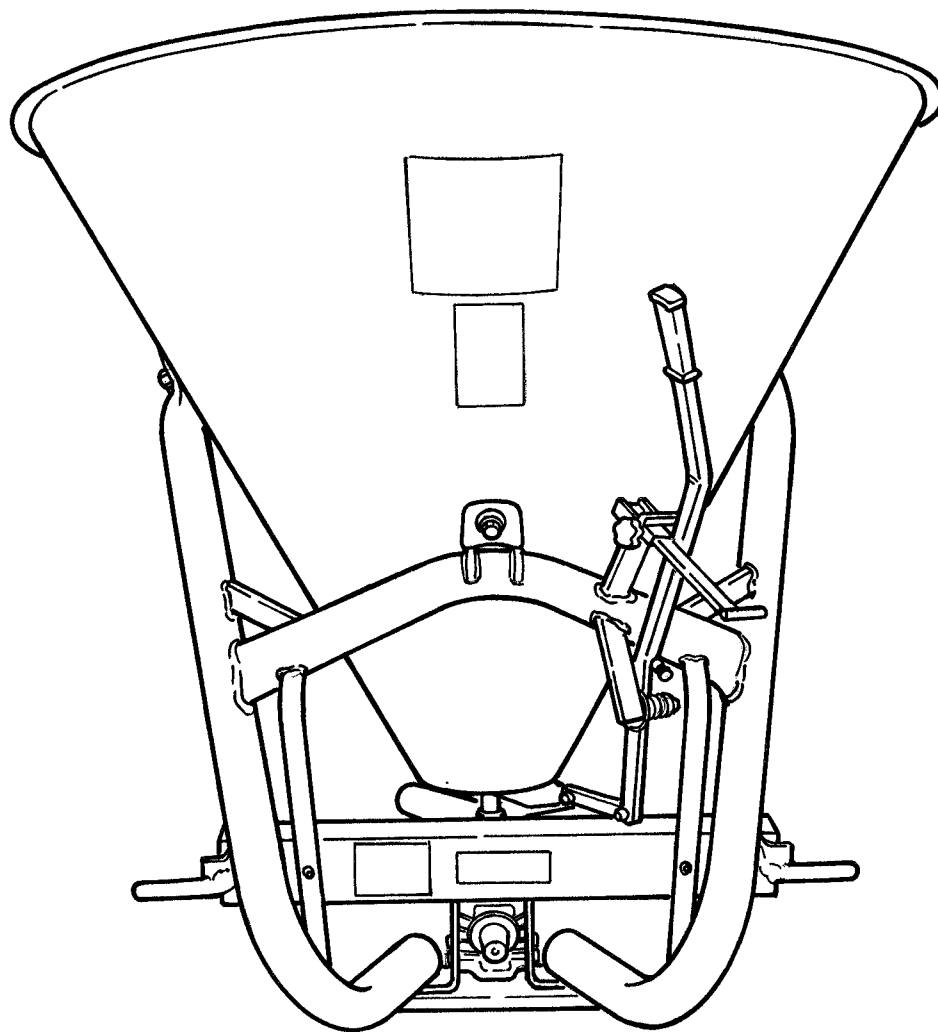

# Rotomec: Hop '300-500'

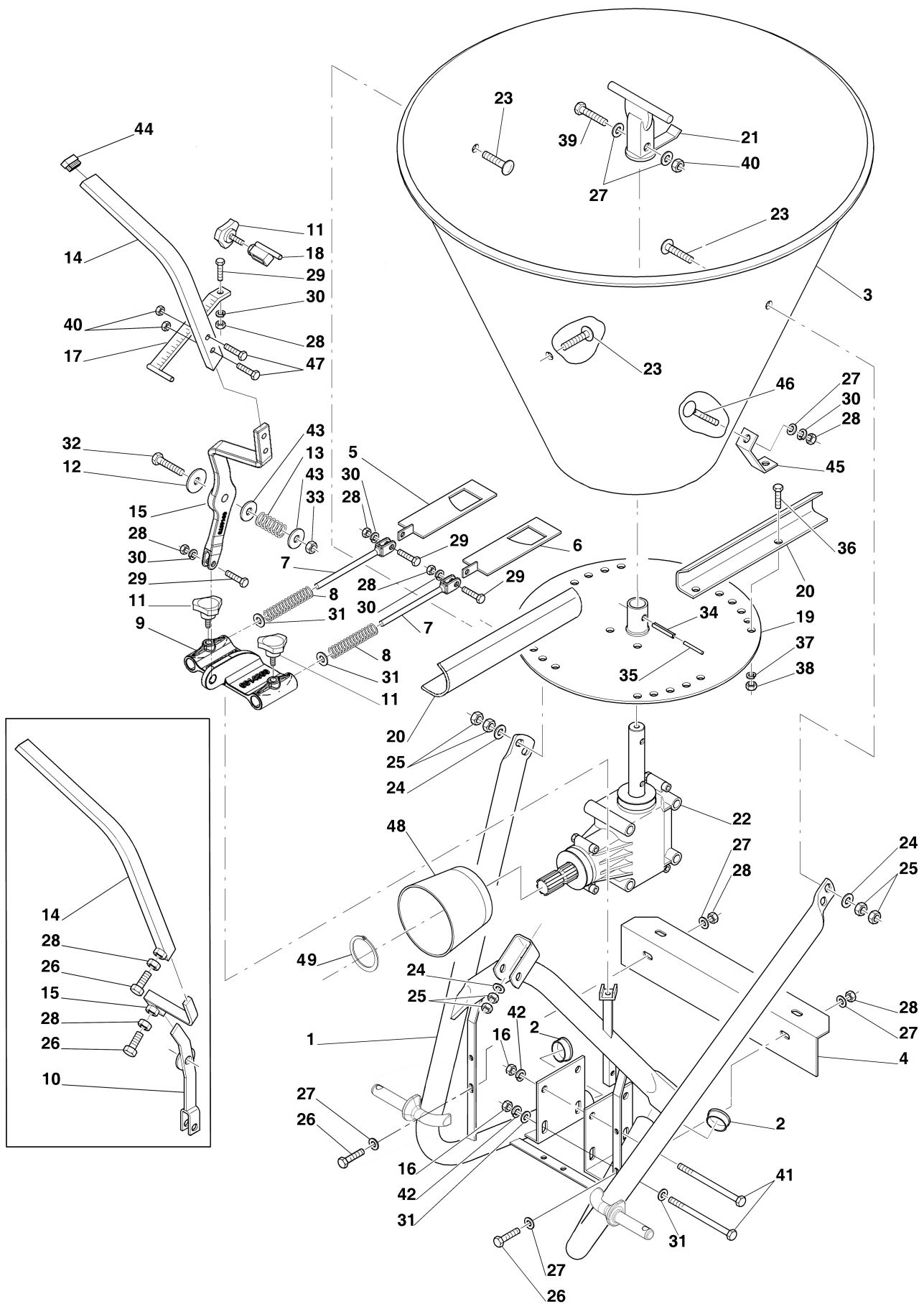

# Rotomec: Hop '300-500'

<b>N.</b>	<b>COD.</b>	<b>DESCRIZIONE</b>	<b>DESCRIPTION</b>	<b>DESCRIPTION</b>	<b>BESCHREIBUNG</b>	<b>N.</b>
1	502-011B	Telaio v.300-500	Frame v.300-500	Châssis v.300-500	Rahmen v.300-500	1
	0014300	Telaio v. 300-500 dal 04/2017	Frame v. 300-500 since 04/2017	Châssis v. 300-500 depuis 04/2017	Rahmen v. 300-500 ab 04/2017	1
2	502-020B	Tappo in gomma Ø60	Rubber cap Ø60	Bouchon Ø60	Deckel Ø60	2
3	502-014B	Tramoggia v.300	Hopper v.300	Trémie v.300	Trichter v.300	1
	502-015B	Tramoggia v.500	Hopper v.500	Trémie v.500	Trichter v.500	1
4	502-013B	Protezione	Protection	Protection	Schutz	1
5	502-009B	Portina destra	Right shutter	Plaque de réglage droite	Rechte Tür	1
6	502-003B	Portina sinistra	Left shutter	Plaque de réglage gauche	Linke Tür	1
7	0014346	Tirante	Tie rod	Tirant complet	Komplette Spindel	2
8	502-024B	Molla tirante	Tension spring	Ressort	Zugfeder	2
9	0014360	Piastra attacco tiranti	Tie attachment plate	Plaque	Zugstangenankupplungsplatte	1
10	0014366	Supporto leva fino al 03/2017	Lever bracket until 03/2017	Support levier jusqu'à 03/2017	DC-Hebelaufgabe bis 03/2017	1
11	501-589B	Volantino M8x16	Adjustment knob M8x16	Vis de fixation M8x16	Stellschraube M8x16	3
12	501-585B	Rondella nylon Ø12x50x6	Nylon washer Ø12x50x6	Rondelle en nylon Ø12x50x6	Scheibe Ø12x50x6	1
13	501-586B	Molla	Spring	Ressort	Feder	1
14	0014380	Leva	Lever	Levier	Hebel	1
	0014375	Leva dal 04/2017	Lever since 04/2017	Levier depuis 04/2017	Hebel ab 04/2017	1
15	0014384	Attacco Leva fino al 03/2017	Hitch Lever until 03/2017	Attache Levier jusqu'à 03/2017	Ankupplung Hebel bis 03/2017	1
	0014370	Supporto leva dal 04/2017	Lever bracket since 04/2017	Support levier depuis 04/2017	DC-Hebelaufgabe ab 04/2017	1
16	0090150	Dado M10	Nut M10	Ecrou M10	Mutter M10	4
17	0014396	Indice graduato	Scaled rod	Index gradué	Gradanzeiger	1
18	0014404	Fermo leva	Lever stop	Arrêt pour levier	Hebelfeststeller	1
19	501-599B	Disco spanditore	Spreader disc	Disque de distribution	Streuscheibe	1
20	501-598B	Aletta spanditrice	Spreader wing	Dispositif de distribution	Getriebedeckel	4
21	501-597B	Agitatore fisso	Stationary stirrer	Agitateur fixe	Feststehender Rührer	1
22	0014690	Gruppo scatola	Gearbox	Boîtier	Gehäusegruppe	1
23	0051073	Vite TTQST M12x30 (V.209)	Bolt TTQST M12x30 (V.209)	Vis TTQST M12x30 (V.209)	Schraube TTQST M12x30 (V.209)	3
	0051073	Vite TTQST M12x30 (V.212)	Bolt TTQST M12x30 (V.212)	Vis TTQST M12x30 (V.212)	Schraube TTQST M12x30 (V.212)	5
24	0091435	Rondella piana Ø14x28 (V.209)	Flat washer Ø14x28 (V.209)	Rondelle plate Ø14x28 (V.209)	Flache Scheibe Ø14x28 (V.209)	3
	0091435	Rondella piana Ø14x28 (V.212)	Flat washer Ø14x28 (V.212)	Rondelle plate Ø14x28 (V.212)	Flache Scheibe Ø14x28 (V.212)	5
25	0001106	Dado M12 (V.209)	Nut M12 (V.209)	Ecrou M12 (V.209)	Mutter M12 (V.209)	6
	0001106	Dado M12 (V.212)	Nut M12 (V.212)	Ecrou M12 (V.212)	Mutter M12 (V.212)	10

# Rotomec: Hop '300-500'

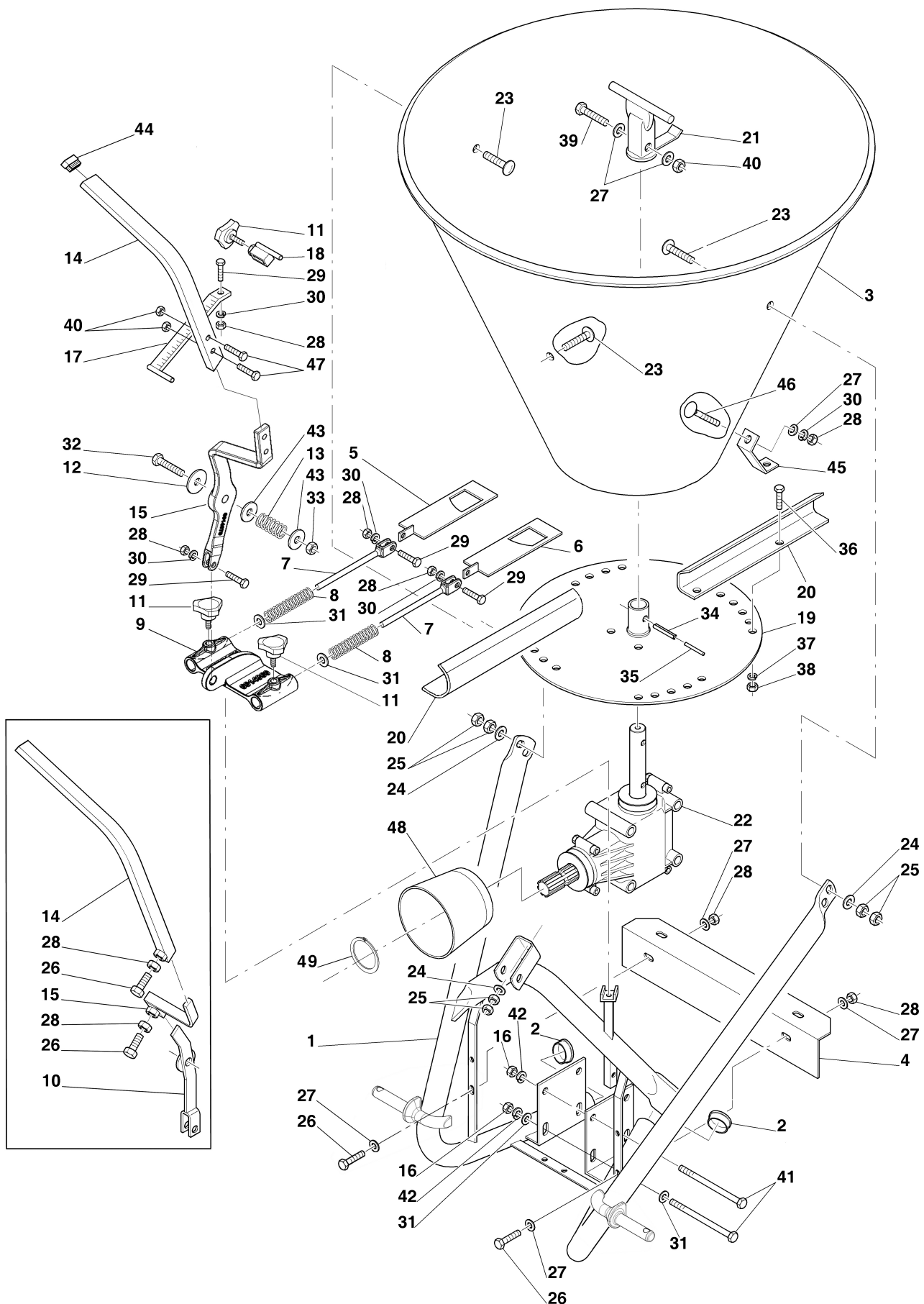

# Rotomec: Hop '300-500'

<b>N.</b>	<b>COD.</b>	<b>DESCRIZIONE</b>	<b>DESCRIPTION</b>	<b>DESCRIPTION</b>	<b>BESCHREIBUNG</b>	<b>N.</b>
26	0015012	Vite TE M8x20	Bolt M8x20	Vis TE M8x20	Schraube M8x20	2
27	0015230	Rondella piana Ø8x17	Flat washer Ø8x17	Rondelle plate Ø8x17	Flache Scheibe Ø8x17	7
28	0046545	Dado M8	Nut M8	Ecrou M8	Mutter M8	7
29	0046543	Vite TE M8x30	Bolt TE M8x30	Vis TE M8x30	Schraube TE M8x30	4
30	0003144	Rondella grower Ø8	Spring washer Ø8	Rondelle à ressort Ø8	Scheibe Ø8	5
31	0002034	Rondella piana Ø10x21	Flat washer Ø10x21	Rondelle plate Ø10x21	Flache Scheibe Ø10x21	6
32	0007128	Vite TE M12x80	Bolt TE M12x80	Vis TE M12x80	Schraube TE M12x80	1
33	0013345	Dado autobloccante M12	Locking nut M12	Ecrou autobloquant M12	Mutter M12	1
34	0029247	Spina elastica Ø8x40	Roll pin Ø8x40	Goupille élastique Ø8x40	Spannstift Ø8x40	1
35	501-596B	Spina elastica Ø5x40	Roll pin Ø5x40	Goupille élastique Ø5x40	Spannstift Ø5x40	1
36	0036319	Vite TE M6x16	Bolt TE M6x16	Vis TE M6x16	Schraube TE M6x16	8
37	0046536	Rondella grower Ø6	Spring washer Ø6	Rondelle à ressort Ø6	Scheibe Ø6	8
38	501-603B	Dado M6	Nut M6	Ecrou M6	Mutter M6	8
39	0014427	Vite TE M8x45	Bolt TE M8x45	Vis TE M8x45	Schraube TE M8x45	1
40	0091384	Dado autobloccante M8	Locking nut M8	Ecrou autobloquant M8	Mutter M8	3
41	0015273	Vite TE M10x110	Bolt TE M10x110	Vis TE M10x110	Schraube TE M10x110	4
42	0001280	Rondella grower Ø10	Spring washer Ø10	Rondelle élastique Ø10	Scheibe Ø10	4
43	0002265	Rondella piana Ø12x24	Flat washer Ø12x24	Rondelle plate Ø12x24	Flache Scheibe Ø12x24	2
44	0014391	Tappo in gomma	Rubber cap	Bouchon	Deckel	1
45	0014338	Piatto di attacco	Attachment plate	Plaque d'attache	Anschlußplatte	1
46	0084289	Vite TTQST M8x20	Bolt TTQST M8x20	Vis TTQST M8x20	Schraube TTQST M8x20	1
47	0091446	Vite TE M8x25	Bolt TE M8x25	Vis TE M8x25	Schraube TE M8x25	2
48	0018531	Protezione cardano	Shaft protection	Protection arbre	Kardangelenschutz	1
49	0014464	Seeger esterno Ø65	Outer snap ring Ø65	Circlip externe Ø65	Außenseegerring Ø65	1

# Rotomec: Hop '300-500'

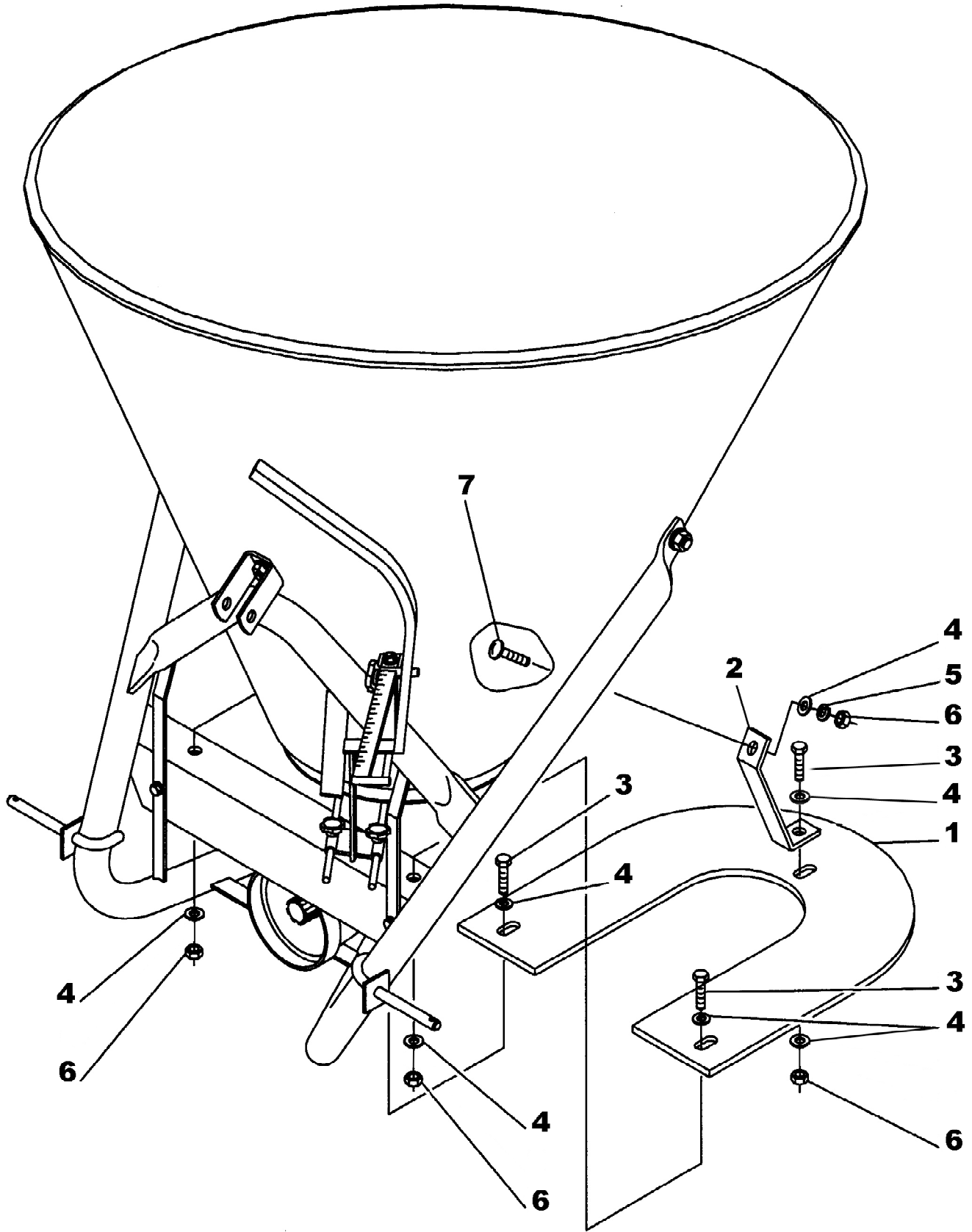

# Rotomec: Hop '300-500'

<b>N.</b>	<b>COD.</b>	<b>DESCRIZIONE</b>	<b>DESCRIPTION</b>	<b>DESCRIPTION</b>	<b>BESCHREIBUNG</b>	<b>N.</b>
1	0014337	Protezione	Protection	Protection	Schutz	1
2	0014338	Piatto di attacco	Attachment plate	Plaque d'attache	Anschlußplatte	1
3	0046454	Vite TE M8x16	Bolt TE M8x16	Vis TE M8x16	Schraube TE M8x16	3
4	0015230	Rondella piana Ø8x17	Flat washer Ø8x17	Rondelle plate Ø8x17	Flache Scheibe Ø8x17	7
5	0003144	Rondella grower Ø8	Spring washer Ø8	Rondelle à ressort Ø8	Scheibe Ø8	1
6	0046545	Dado M8	Nut M8	Ecrou M8	Mutter M8	4
7	0084289	Vite TTQST M8x20	Bolt TTQST M8x20	Vis TTQST M8x20	Schraube TTQST M8x20	1

# Rotomec: Hop '300-500'

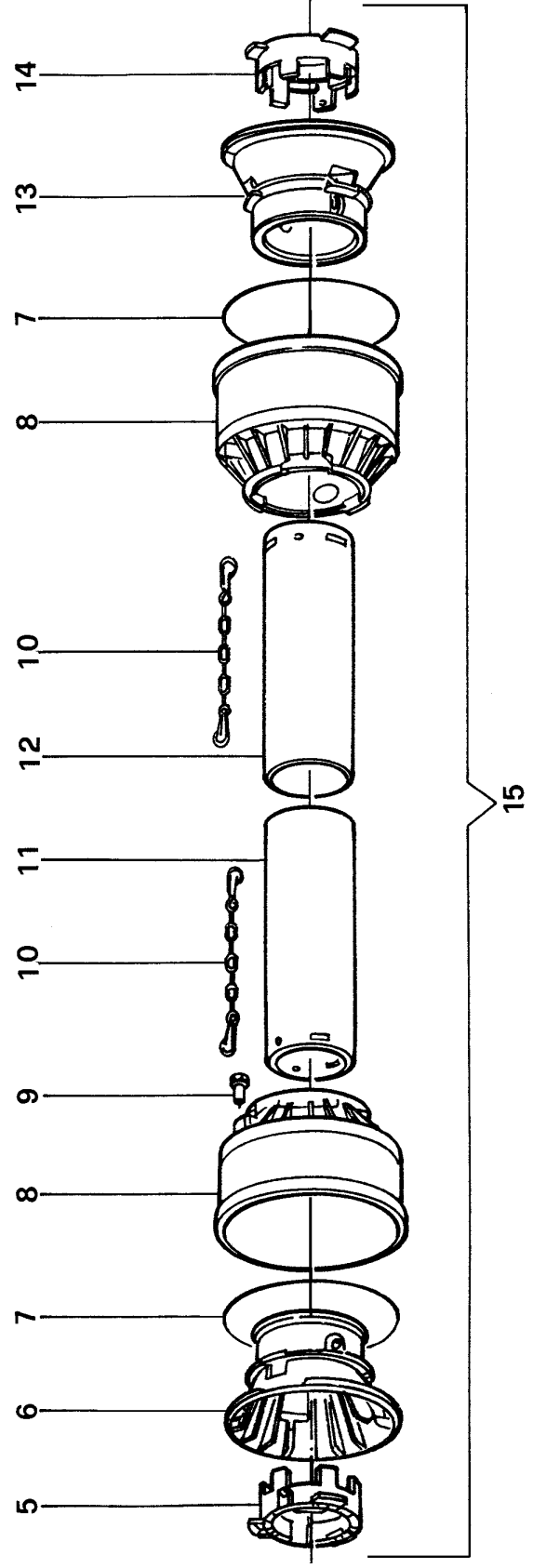
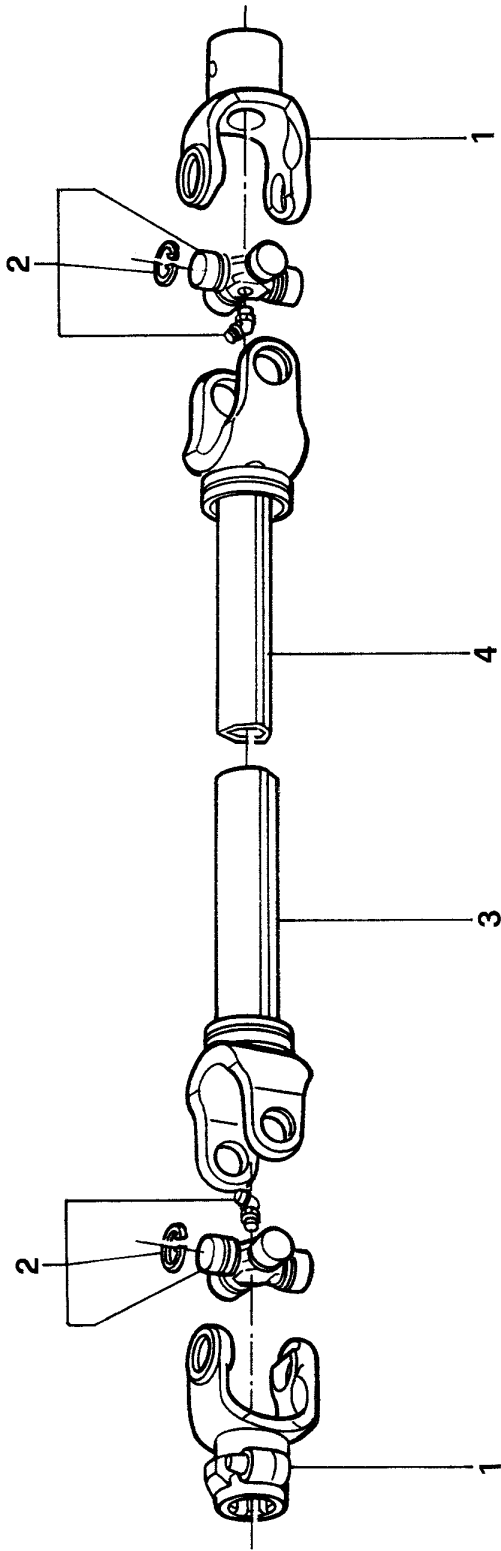

# Rotomec: Hop '300-500'

N.	COD.	DESCRIZIONE	DESCRIPTION	DESCRIPTION	BESCHREIBUNG	N.
1	1021010C	Forcella P.D.F.	PTO Yoke	Fourche P.D.F.	Aufsteckgabel	2
2	1001005C	Crociera	Cross & Bearing	Croisillon	Kreuzgelenk	2
3	1981034NC	Tubo esterno	Outer tube	Tube externe	Außenrohr	1
4	1991035NC	Tubo interno	Inner tube	Tube interne	Innenrohr	1
5	1781005C	Anello tubo esterno	Outer locking ring	Anneau tube externe	Außenrohrring	1
	1781210C	Anello tubo esterno dal 01/10/05	Outer locking ring since 01/10/05	Anneau tube externe dès 01/10/05	Außenrohrring ab 01/10/05	1
	1781210CA	Anello tubo esterno dal 01/01/07	Outer locking ring since 01/01/07	Anneau tube externe dès 01/01/07	Außenrohrring ab 01/01/07	1
6	1784201C	Controcuffia tubo esterno fino 31/12/06	Outer tube rigid cone until 31/12/06	Contre coiffe tube externe jusqu'à 31/12/06	Außenrohrgegentopf bis 31/12/06	1
7	1211233C	Anello di rinforzo	Stiffening ring	Anneau de renforcement	Verstärkungsring	2
	1213233C	Anello di rinforzo dal 01/10/05 fino 31/12/06	Stiffening ring since 01/10/05 until 31/12/06	Anneau de renforcement dès 01/10/05 jusqu'à 31/12/06	Verstärkungsring ab 01/10/05 bis 31/12/06	2
8	1781003C	Cuffia esterna	Outer cone	Coiffe externe	Außenschutztopf	2
	1784203C	Cuffia esterna dal 01/10/05	Outer cone since 01/10/05	Coiffe externe dès 01/10/05	Außenschutztopf ab 01/10/05	2
	1784203CA	Cuffia esterna dal 01/01/07	Outer cone since 01/01/07	Coiffe externe dès 01/01/07	Außenschutztopf ab 01/01/07	2
9	1784212C	Spina di bloccaggio fino 31/12/06	Pin until 31/12/06	Goupille jusqu'à 31/12/06	Haltestift bis 31/12/06	2
10	1006065C	Catenella	Chain	Chaîne	Kette	2
11	1770036C	Tubo protezione esterna	Female tube shield	Tube protection femelle	Außenschutzrohr	1
	1773032C	Tubo protezione esterna dal 01/10/05	Female tube shield since 01/10/05	Tube protection femelle dès 01/10/05	Außenschutzrohr ab 01/10/05	1
	1773032CA	Tubo protezione esterna dal 01/01/07	Female tube shield since 01/01/07	Tube protection femelle dès 01/01/07	Außenschutzrohr ab 01/01/07	1
12	1871036C	Tubo protezione interna	Male tube shield	Tube protection mâle	Innenschutzrohr	1
	1872032C	Tubo protezione interna dal 01/10/05	Male tube shield since 01/10/05	Tube protection mâle dès 01/10/05	Innenschutzrohr ab 01/10/05	1
	1872032CA	Tubo protezione interna dal 01/01/07	Male tube shield since 01/01/07	Tube protection mâle dès 01/01/07	Innenschutzrohr ab 01/01/07	1
13	1784202C	Controcuffia tubo interno fino 31/12/06	Inner tube rigid cone since 31/12/06	Contre coiffe tube interne jusqu'à 31/12/06	Innenrohrgegentopf bis 31/12/06	1
14	1781004C	Anello tubo interno	Inner locking ring	Anneau tube interne	Innenrohrring	1
	1781211C	Anello tubo interno dal 01/10/05	Inner locking ring since 01/10/05	Anneau tube interne dès 01/10/05	Innenrohrring ab 01/10/05	1
	1781211CA	Anello tubo interno dal 01/01/07	Inner locking ring since 01/01/07	Anneau tube interne dès 01/01/07	Innenrohrring ab 01/01/07	1
15	92SS1033C	Protezione completa	Complete shielding	Protection complète	Kompletter Schutz	1
	90SS1032C	Protezione completa dal 01/10/05	Complete shielding since 01/10/05	Protection complète dès 01/10/05	Kompletter Schutz ab 01/10/05	1
	90SS1032CA	Protezione completa dal 01/01/07	Complete shielding since 01/01/07	Protection complète dès 01/01/07	Kompletter Schutz ab 01/01/07	1
	8680105C	Cardano	PTO shaft	Arbre à cardan	Kardangelenk	1
	0500474	Cardano dal 01/10/05	PTO shaft since 01/10/05	Arbre à cardan dès 01/10/05	Kardangelenk ab 01/10/05	1
	0500488	Cardano dal 01/01/07 solo "CE"	PTO shaft since 01/01/07 only "CE"	Arbre à cardan dès 01/01/07 seulement "CE"	Kardangelenk ab 01/01/07 nur "CE"	1
	0500487	Cardano dal 01/01/07 solo "USA"	PTO shaft since 01/01/07 only "USA"	Arbre à cardan dès 01/01/07 seulement "USA"	Kardangelenk ab 01/01/07 nur "USA"	1

# Rotomec: Hop '300-500'

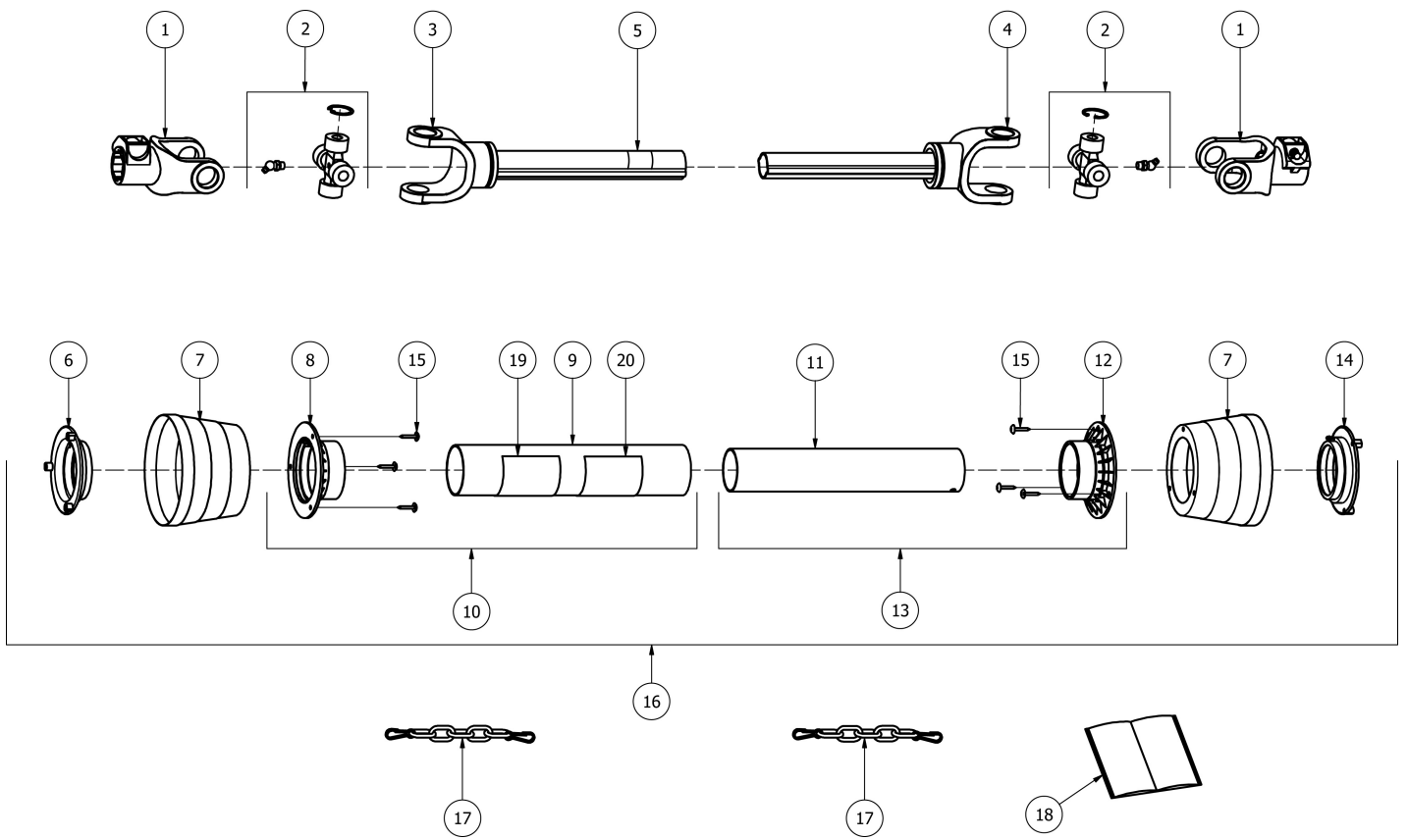

# Rotomec: Hop '300-500'

<b>N.</b>	<b>COD.</b>	<b>DESCRIZIONE</b>	<b>DESCRIPTION</b>	<b>DESCRIPTION</b>	<b>BESCHREIBUNG</b>	<b>N.</b>
1	0800103AB	Forcella P.D.F.	PTO Yoke	Fourche P.D.F.	Aufsteckgabel	2
2	08201CB	Crociera	Cross & Bearing	Croisillon	Kreuzgelenk	2
3	15010522B	Tubo esterno	Outer tube	Tube externe	Außenrohr	1
4	15010521B	Tubo interno	Inner tube	Tube interne	Innenrohr	1
5	950-464B	Adesivo interno	Inner decal	Autocollant intérieur	Innerer Aufkleber	1
6	5501C001B	Anello tubo esterno	Outer locking ring	Anneau tube externe	Außenrohrring	1
7	1902C001B	Cuffia di protezione	Guard cone	Coiffe de protection	Maschinenseite Schutzhaube	2
8	5402C001B	Imbuto esterno	Outer cone	Calotte extrene	Außenhaube	1
9	961NL052B	Tubo protezione esterna	Female tube shield	Tube protection femelle	Außenschutzrohr	1
10	4L010522B	Tubo esterno completo	Outer tube complete	Tube externe complet	Außenrohr komplett	1
11	955NL052B	Tubo protezione interna	Male tube shield	Tube protection mâle	Innenschutzrohr	1
12	5402C002B	Imbuto interno	Inner cone	Calotte interne	Innenhaube	1
13	4L010521B	Tubo interno completo	Inner tube complete	Tube interne complet	Innenrohr komplett	1
14	5501C002B	Anello tubo interno	Inner locking ring	Anneau tube interne	Innenrohrring	1
15	98052242B	Vite autofillettante Ø4,8x22	Self-tapping screw Ø4,8x22	Vis autotaradeuse Ø4,8x22	Blechschrabe Ø4,8x22	6
16	3CE01052B	Protezione completa	Complete shielding	Protection complète	Kompletter Schutz	1
17	52000001B	Catenella	Chain	Chaîne	Kette	2
18	09872101B	Manuale di istruzioni	Operator's manual	Livret d'entretien et d'utilisation	Bedienungs- und Wartungsanleitung	1
19	09872010B	Adesivo esterno "CE"	Outer decal "CE"	Autocollant extérieur "CE"	Außerer Aufkleber "CE"	1
20	950-463B	Adesivo esterno "USA"	Outer decal "USA"	Autocollant extérieur "USA"	Außerer Aufkleber "USA"	1
	0500121	Cardano	PTO shaft	Arbre à cardan	Kardangelenk	1

# Rotomec: Hop '300-500'

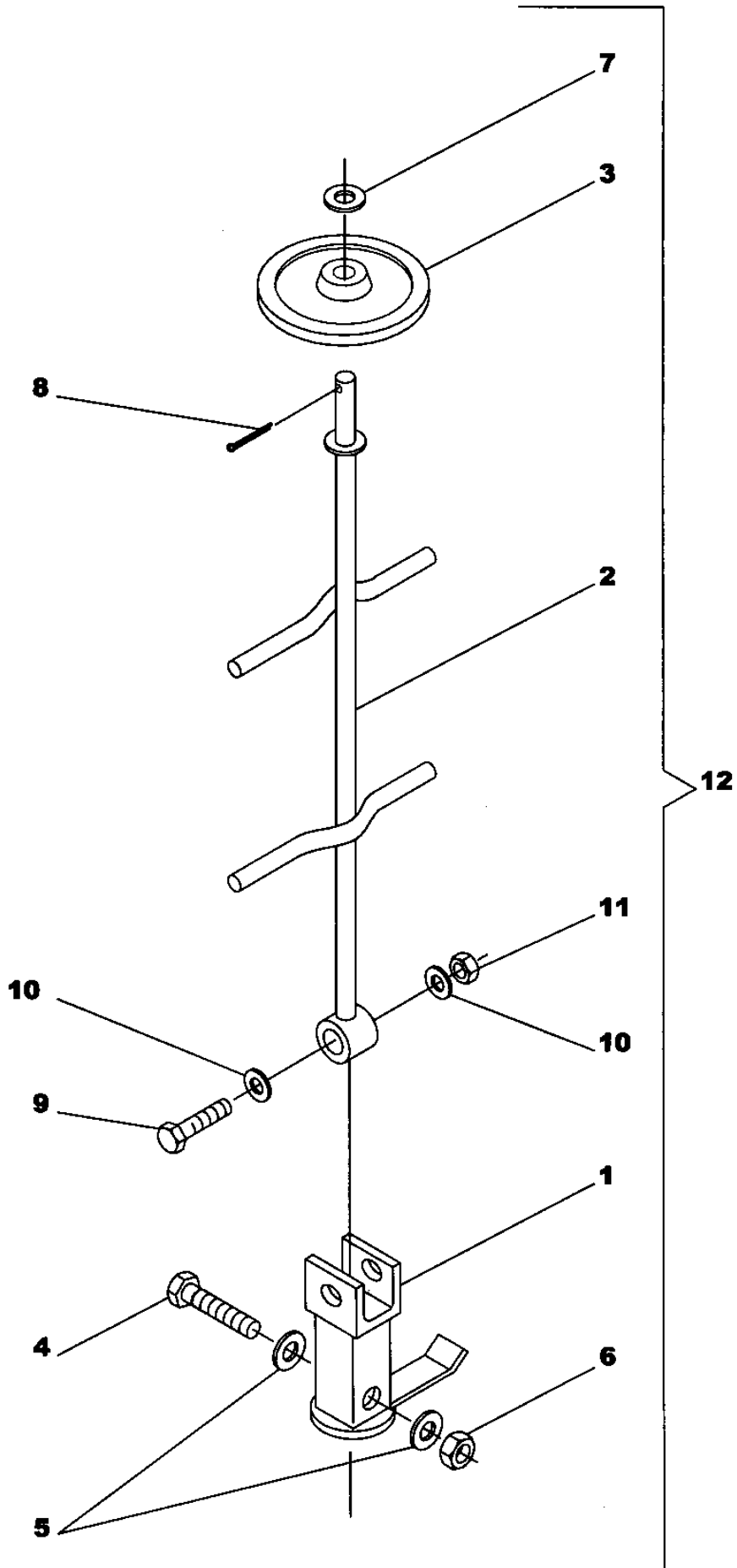

# Rotomec: Hop '300-500'

<b>N.</b>	<b>COD.</b>	<b>DESCRIZIONE</b>	<b>DESCRIPTION</b>	<b>DESCRIPTION</b>	<b>BESCHREIBUNG</b>	<b>N.</b>
1	502-019B	Agitatore per polvere	Articulated powder stirrer	Agitateur pour poudre	Pulverrührer	1
2	502-007B	Asta snodata per polvere	Articulated stirrer beam	Tige articulée pour poudre	Gelenkstange für Pulver	1
3	502-005B	Ruota appoggio in gomma	Articulated stirrer wheel	Roue d'appui en caoutchouc	Stützrad aus Gummi	1
4	0014490	Vite TE M8x50	Bolt TE M8x50	Vis TE M8x50	Schraube TE M8x50	1
5	0015230	Rondella piana Ø8	Flat washer Ø8	Rondelle plate Ø8	Flache Scheibe Ø8	2
6	0091384	Dado autobloccante M8	Locking nut M8	Ecrou autobloquant M8	Mutter M8	1
7	0002265	Rondella piana Ø12	Flat washer Ø12	Rondelle plate Ø12	Flache Scheibe Ø12	1
8	0001174	Copiglia Ø4x35	Cotter pin Ø4x35	Goupille Ø4x35	Splint Ø4x35	1
9	0014477	Vite TE M10x60	Bolt TE M10x60	Vis TE M10x60	Schraube TE M10x60	1
10	0002034	Rondella piana Ø10	Flat washer Ø10	Rondelle plate Ø10	Flache Scheibe Ø10	2
11	0014106	Dado autobloccante M10	Locking nut M10	Ecrou autobloquant M10	Mutter M10	1
12	AA3-120	Agitatore a ruota completo fino al 10/2011	Complete agitator extension until 10/2011	Agitateur à roue complet jusqu'à 10/2011	Kompletter Rührer mit Rad bis 10/2011	1

# Rotomec: Hop '300-500'

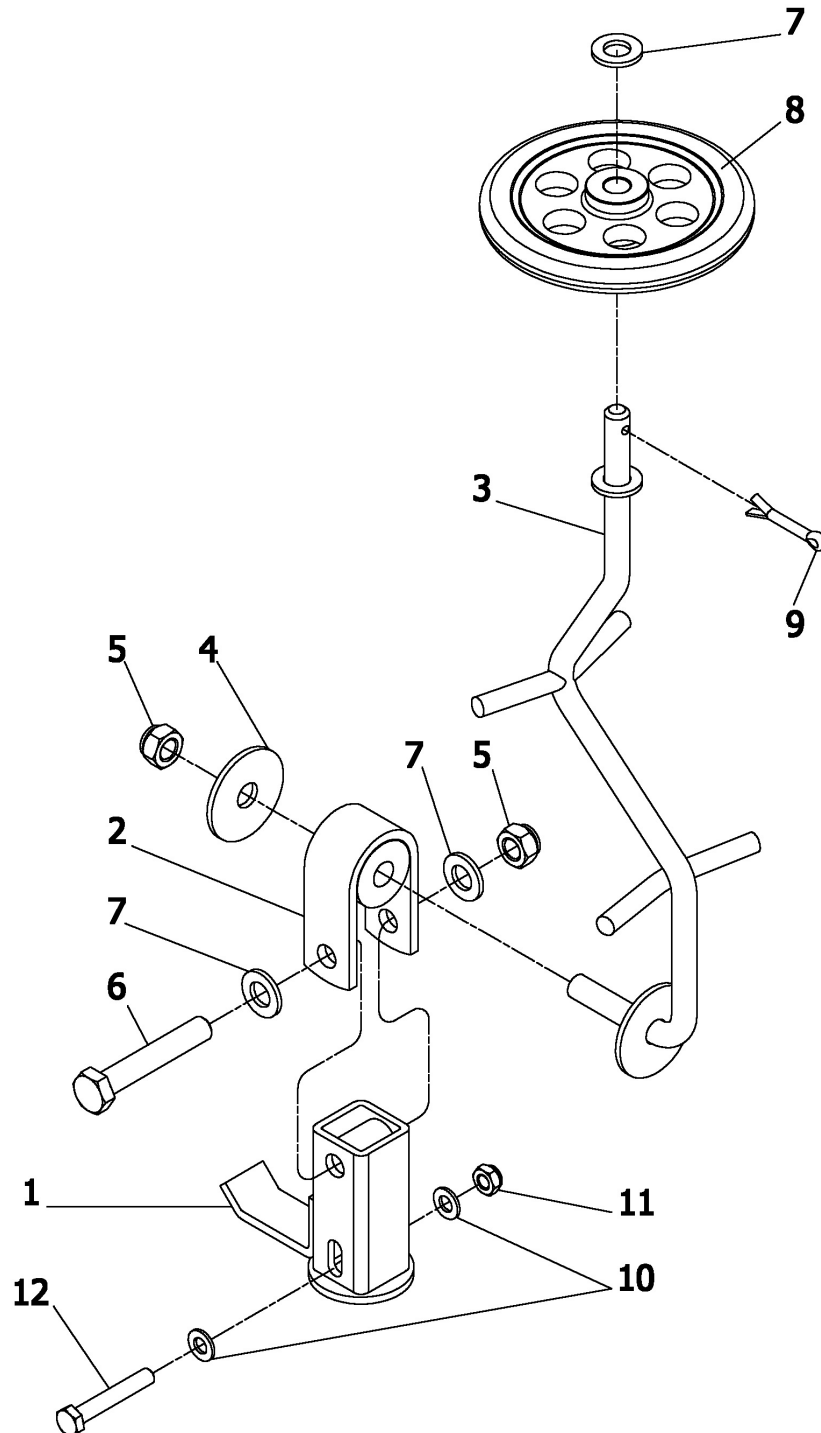

# Rotomec: Hop '300-500'

<b>N.</b>	<b>COD.</b>	<b>DESCRIZIONE</b>	<b>DESCRIPTION</b>	<b>DESCRIPTION</b>	<b>BESCHREIBUNG</b>	<b>N.</b>
1	0014485	Agitatore per polvere	Articulated powder stirrer	Agitateur pour poudre	Pulverrührer	1
2	0014478	Snodo completo	Ball joint	Joint complet	Kugelförmig Gelenk	1
3	0014470	Asta snodata completa	Complete articulated stirrer beam	Tige articulée complète	Komplette Gelenkstange	1
4	0057273	Rondella piana Ø12	Flat washer Ø12	Rondelle plate Ø12	Flache Scheibe Ø12	1
5	0030064	Dado M12 DIN 980	Nut M12 DIN 980	Ecrou M12 DIN 980	Mutter M12 DIN 980	2
6	0192236	Vite TE M12x70	Bolt TE M12x70	Vis TE M12x70	Schraube TE M12x70	1
7	0002265	Rondella piana Ø12	Flat washer Ø12	Rondelle plate Ø12	Flache Scheibe Ø12	3
8	0014488	Ruota di appoggio	Articulated stirrer wheel	Roue d'appui	Stützrad	1
9	0001174	Copiglia Ø4x35	Cotter pin Ø4x35	Goupille Ø4x35	Splint Ø4x35	1
10	0015230	Rondella piana Ø8	Flat washer Ø8	Rondelle plate Ø8	Flache Scheibe Ø8	2
11	0091384	Dado autobloccante M8	Locking nut M8	Ecrou autobloquant M8	Mutter M8	1
12	0014490	Vite TE M8x50	Bolt TE M8x50	Vis TE M8x50	Schraube TE M8x50	1
	0099978	Agitatore a ruota completo dal 11/2011	Complete agitator extension since 11/2011	Agitateur à roue complet depuis 11/2011	Kompletter Rührer mit Rad ab 11/2011	

# Rotomec: Hop '300-500'

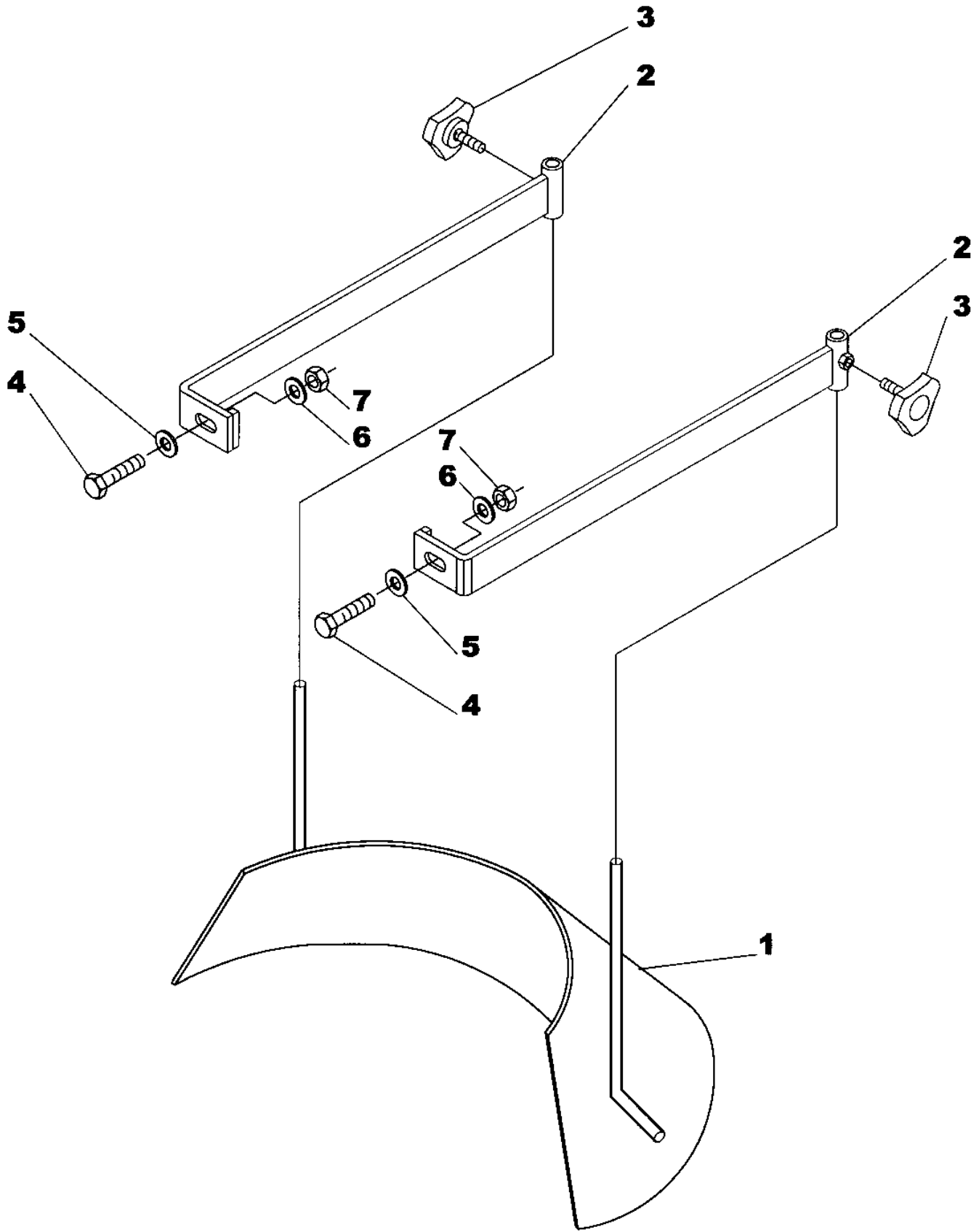

# Rotomec: Hop '300-500'

<b>N.</b>	<b>COD.</b>	<b>DESCRIZIONE</b>	<b>DESCRIPTION</b>	<b>DESCRIPTION</b>	<b>BESCHREIBUNG</b>	<b>N.</b>
1	0014501	Deflettore per regolazione	Deflector shield	Défecteur pour le réglage	Umlenklech zur Einstellung	1
2	0014505	Attacco deflettore	Deflector connection	Attelage déflecteur	Umlenklechankupplung	2
3	501-589B	Volantino M8x16	Adjustment knob M8x16	Vis de fixation M8x16	Stellschraube M8x16	2
4	0046543	Vite TE M8x30	Bolt TE M8x30	Vis TE M8x30	Schraube TE M8x30	2
5	0014514	Rondella piana Ø8X24	Flat washer Ø8X24	Rondelle plate Ø8X24	Flache Scheibe Ø8X24	2
6	0015230	Rondella piana Ø8X17	Flat washer Ø8X17	Rondelle plate Ø8X17	Flache Scheibe Ø8X17	2
7	0091384	Dado autobloccante M8	Locking nut M8	Ecrou autobloquant M8	Mutter M8	2
	0099638	Deflettore completo	Deflector shield complete	Défecteur complet	Leitblech komplett	

# Rotomec: Hop '300-500'

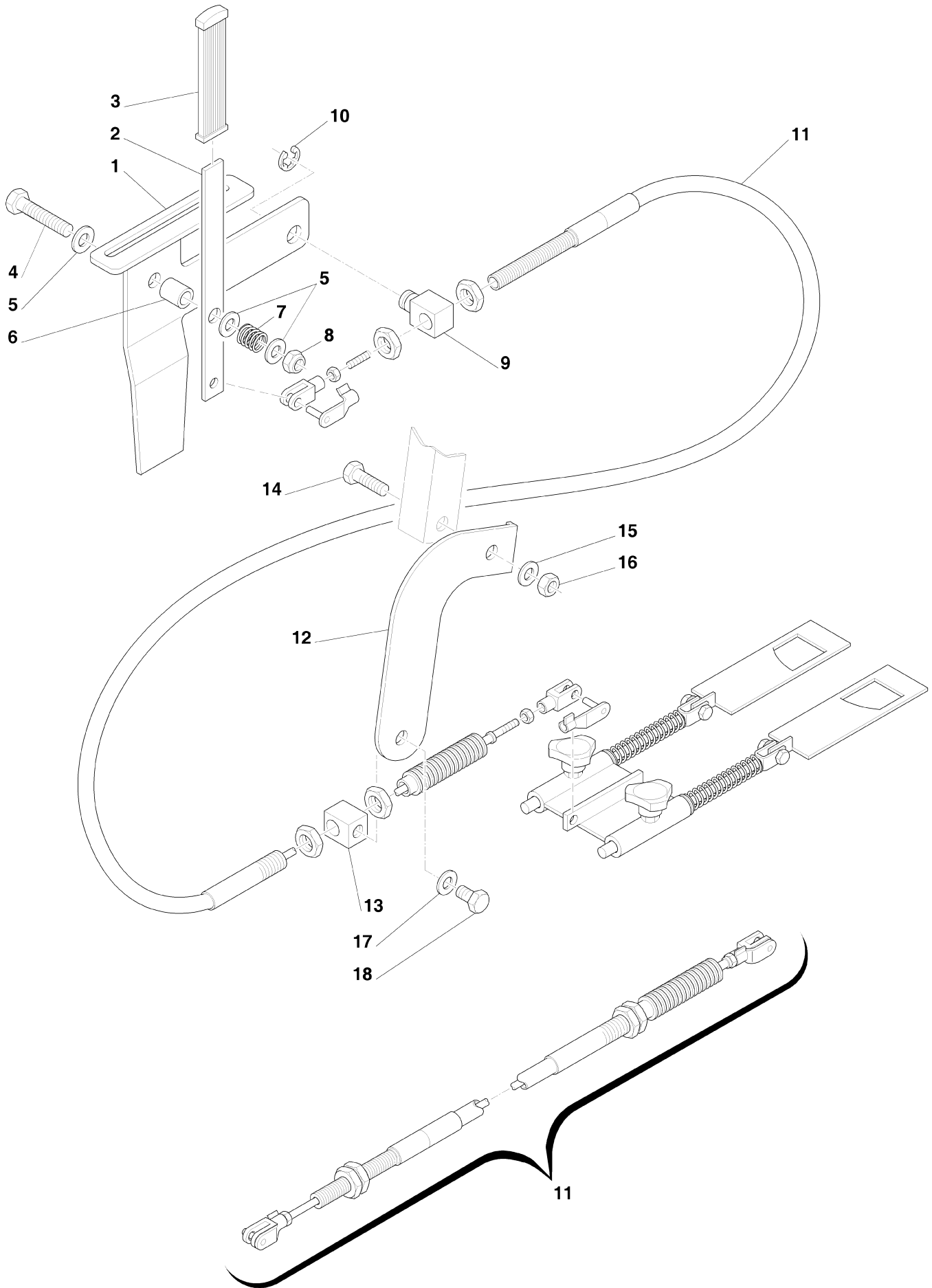

# Rotomec: Hop '300-500'

N.	COD.	DESCRIZIONE	DESCRIPTION	DESCRIPTION	BESCHREIBUNG	N.
1	0114981	Piastra supporto leva comando	Support plate for remote control	Plaque support levier	Hebelsupportsplatte	1
	0014981	Piastra supporto leva comando dal 09/08	Support plate for remote control since 09/08	Plaque support levier dès 09/08	Hebelsupportsplatte ab 09/08	1
2	0014982	Leva di comando	Remote control lever	Levier commande à distance	Fernanlaßbedienungshebel	1
3	0014983	Manopola piatta rigata	Flat grooved handle	Poignée plate gouffrée	Flacher geschlitzte Handgriff	1
4	0014477	Vite TE M10x60	Bolt TE M10x60	Vis TE M10x60	Schraube TE M10x60	1
5	0002034	Rondella piana Ø10	Flat washer Ø10	Rondelle plate Ø10	Flache Scheibe Ø10	3
6	0014988	Distanziale	Spacer	Entretoise	Distanzstück	1
7	0014989	Molla	Spring	Ressort	Feder	1
8	0015237	Dado autobloccante M10	Locking nut M10	Ecrou autobloquant M10	Mutter M10	1
9	0014990	Sostegno per cavo	Cable support	Support câble	Kabelsupport	1
10	0014991	Seeger esterno Ø10	Outer snap ring Ø10	Circlip externe Ø10	Außenseegerring Ø10	1
11	0014992	Cavo	Cable	Câble	Kabel	1
	0014997	Cavo dal 09/08	Cable since 09/08	Câble dès 09/08	Kabel ab 09/08	1
12	0014590	Staffa sostegno cavo	Bracket for cable support	Étrier support câble	Kabelsupportballast	1
13	0014594	Sostegno per cavo	Cable support	Support câble	Kabelsupport	1
14	0015255	Vite TE M12x30	Bolt TE M12x30	Vis TE M12x30	Schraube TE M12x30	1
15	0002265	Rondella piana Ø12	Flat washer Ø12	Rondelle plate Ø12	Flache Scheibe Ø12	1
16	0013345	Dado autobloccante M12	Locking nut M12	Ecrou autobloquant M12	Mutter M12	1
17	0003144	Rosetta elastica Ø8	Lock washer Ø8	Rondelle à ressort Ø8	Scheibe Ø8	1
18	0046454	Vite TE M8x16	Bolt TE M8x16	Vis TE M8x16	Schraube TE M8x16	1
	0099850	Comando apertura a distanza con cavo completo	Remote control cable with complete cable	Commande ouverture à distance avec câble complet	Fernanlassbedienung mit Kabel komplett	

# Rotomec: Hop '300-500'

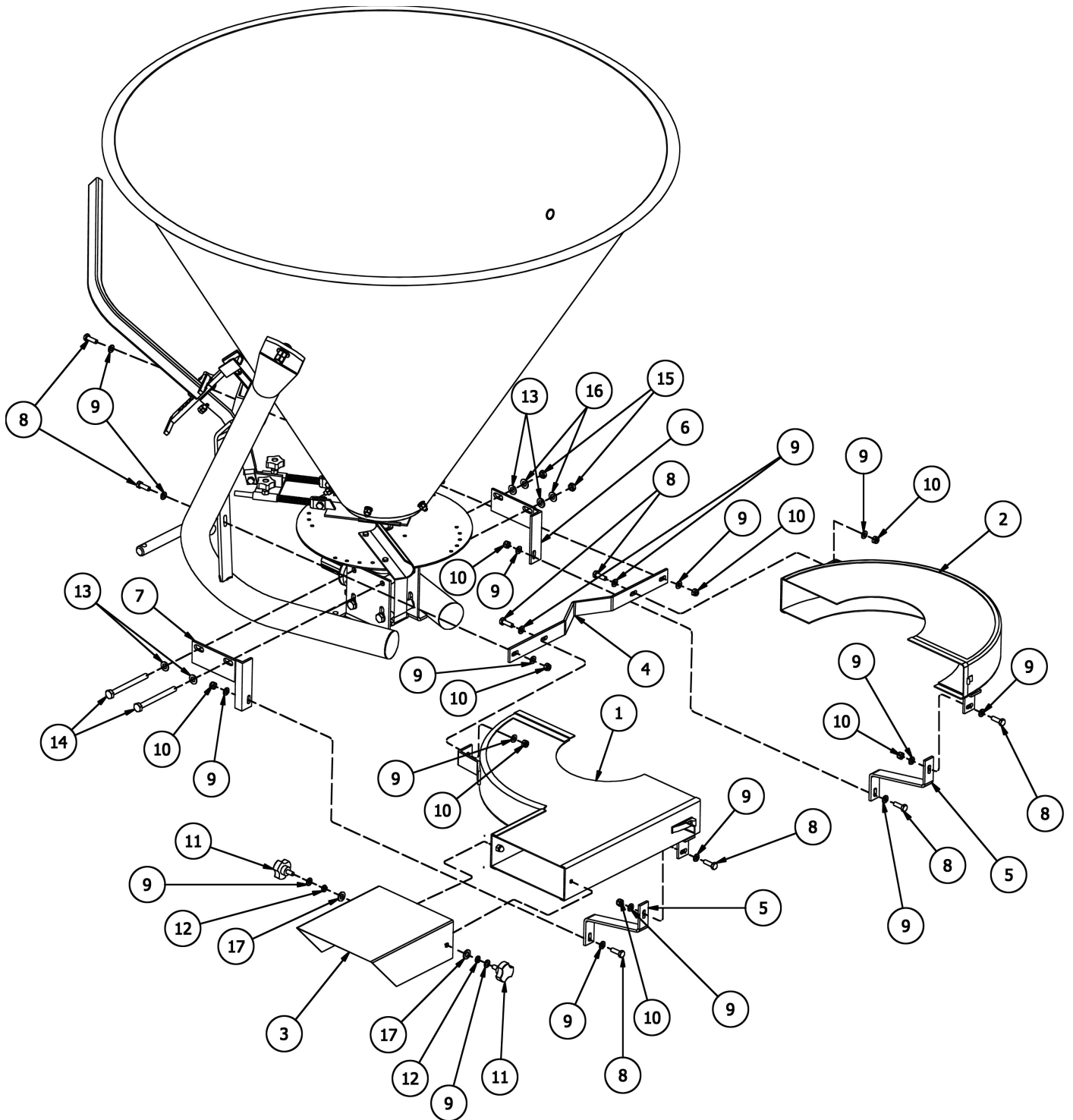

# Rotomec: Hop '300-500'

<b>N.</b>	<b>COD.</b>	<b>DESCRIZIONE</b>	<b>DESCRIPTION</b>	<b>DESCRIPTION</b>	<b>BESCHREIBUNG</b>	<b>N.</b>
1	503-701B	Semi convogliatore sx	Left half conveyor	Demi-convoyeur gauche	Linker Halfförderer	1
2	503-702B	Semi convogliatore dx	Right half conveyor	Demi-convoyeur droit	Rechter Halfförderer	1
3	503-703B	Lamiera convogliatrice	Baffle plate	Tôle de guidage	Förderblech	1
4	503-704B	Piatto di attacco	Conveyor attachment	Plaque d'attache	Anschlußplatte	1
5	503-705B	Piatto sostegno convogliatore	Conveyor bracket	Plaque de support convoyeur	Förderstützplatte	2
6	503-706B	Staffa di attacco dx	Right bracket attachment plate	Etrier d'attelage droit	Rechter Anschlußbügel	1
7	503-707B	Staffa di attacco sx	Left bracket attachment plate	Etrier d'attelage gauche	Linker Anschlußbügel	1
8	0091446	Vite TE M8x25	Bolt TE M8x25	Vis TE M8x25	Schraube TE M8x25	8
9	0015230	Rondella piana Ø8	Flat washer Ø8	Rondelle plate Ø8	Flache Scheibe Ø8	18
10	0091384	Dado autobloccante M8	Locking nut M8	Ecrou autobloquant M8	Mutter M8	8
11	501-589B	Volantino M8x16	Adjustment knob M8x16	Vis de fixation M8x16	Stellschraube M8x16	2
12	0003144	Rosetta elastica Ø8	Lock washer Ø8	Rondelle à ressort Ø8	Scheibe Ø8	2
13	0002034	Rondella piana Ø10	Flat washer Ø10	Rondelle plate Ø10	Flache Scheibe Ø10	4
14	0015263	Vite TE M10x120	Bolt TE M10x120	Vis TE M10x120	Schraube TE M10x120	2
15	0090150	Dado M10	Nut M10	Ecrou M10	Mutter M10	2
16	0001280	Rondella grower Ø10	Spring washer Ø10	Rondelle élastique Ø10	Scheibe Ø10	2
17	0014514	Rondella piana Ø8 Fascia larga	Flat washer Ø8 Large band	Rondelle plate Ø8 Bande large	Flache Scheibe Ø8 Breites Band	2
	AA4-120	Convogliatore scarico laterale Completo fino al 10/2016	Complete side row discharge until 10/2016	Convoyeur latéral complet jusqu'à 10/2016	Seitlicher Förderer komplett bis 10/2016	1

# Rotomec: Hop '300-500'

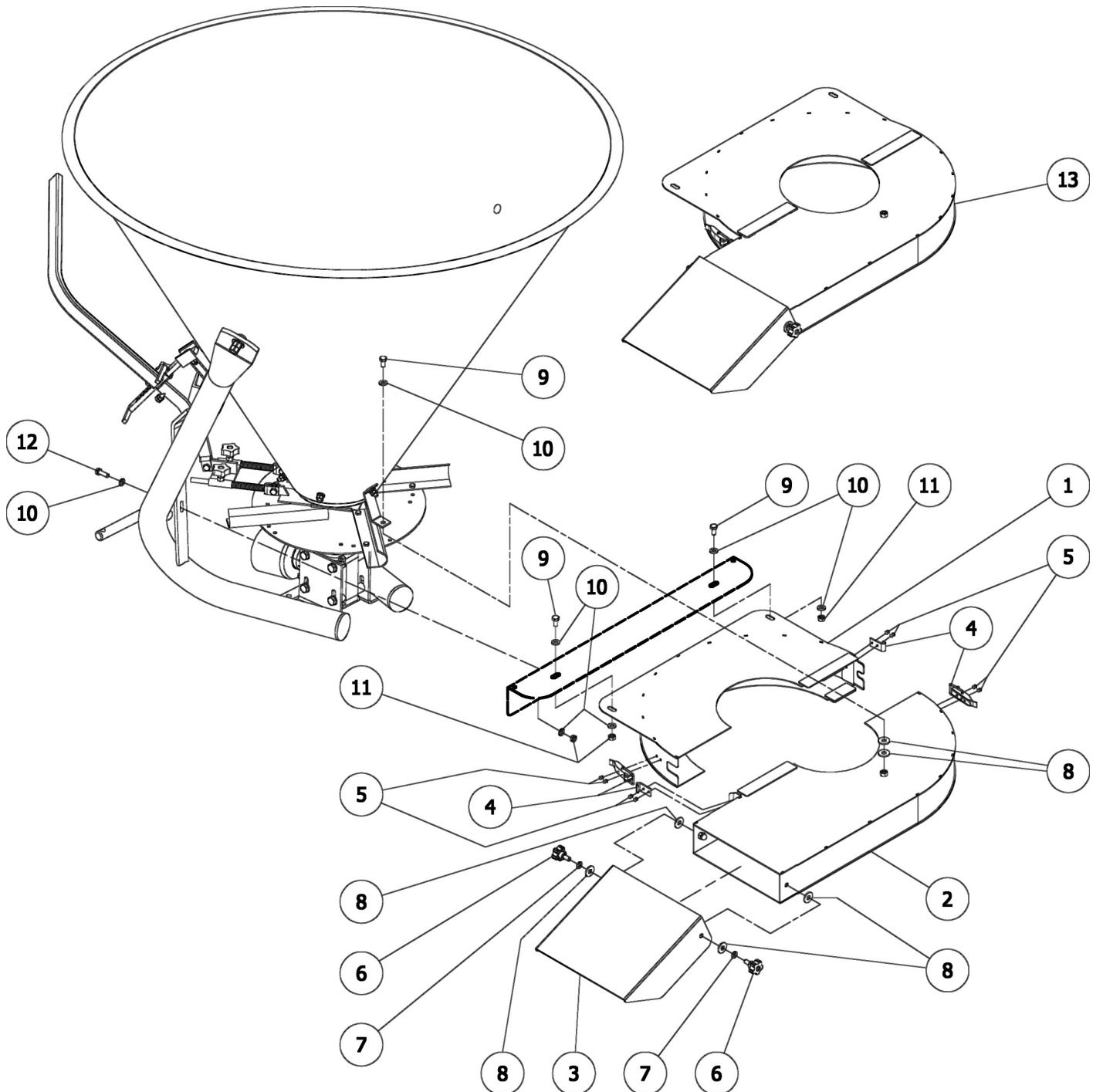

# Rotomec: Hop '300-500'

<b>N.</b>	<b>COD.</b>	<b>DESCRIZIONE</b>	<b>DESCRIPTION</b>	<b>DESCRIPTION</b>	<b>BESCHREIBUNG</b>	<b>N.</b>
1	0014530	Semi convogliatore anteriore	Front half conveyer	Demi-convoyeur avant	Vorderhalbförderer	1
2	0014540	Semi convogliatore posteriore	Rear half conveyer	Demi-convoyeur arrière	Heckhalbförderer	1
3	0014550	Lamiera convogliatrice	Baffle plate	Tôle de guidage	Förderblech	1
4	0014531	Chiusura a leva	Side latch	Fermeture par levier	Hebelverschluss	2
5	0014553	Rivetto Ø4 x 10 acciaio inox	Rivet	Rivet	Niet	8
6	501-589B	Volantino M8x16	Adjustment knob M8x16	Vis de fixation M8x16	Stellschraube M8x16	2
7	0003144	Rosetta elastica Ø8	Lock washer Ø8	Rondelle à ressort Ø8	Scheibe Ø8	2
8	0014514	Rondella piana Ø8 Fascia larga	Flat washer Ø8 Large band	Rondelle plate Ø8 Bande large	Flache Scheibe Ø8 Breites Band	6
9	0046454	Vite TE M8x16 (non inclusa)	Bolt TE M8x16 (not included)	Vis TE M8x16 (pas incluse)	Schraube TE M8x16 (nicht inbegriffen)	3
10	0015230	Rondella piana Ø8 (non inclusa)	Flat washer Ø8 (not included)	Rondelle plate Ø8 (pas incluse)	Flache Scheibe Ø8 (nicht inbegriffen)	9
11	0046545	Dado M8 (non incluso)	Nut M8 (not included)	Ecrou M8 (pas inclus)	Mutter M8 (nicht inbegriffen)	4
12	0015012	Vite TE M8x20 (non inclusa)	Bolt TE M8x20 (not included)	Vis TE M8x20 (pas incluse)	Schraube TE M8x20 (nicht inbegriffen)	2
13	0099458	Convogliatore scarico laterale completo dal 11/2016	Complete side row discharge since 11/2016	Convoyeur latéral complet depuis 11/2016	Seitlicher Förderer komplett ab 11/2016	1

# Rotomec: Hop '300-500'

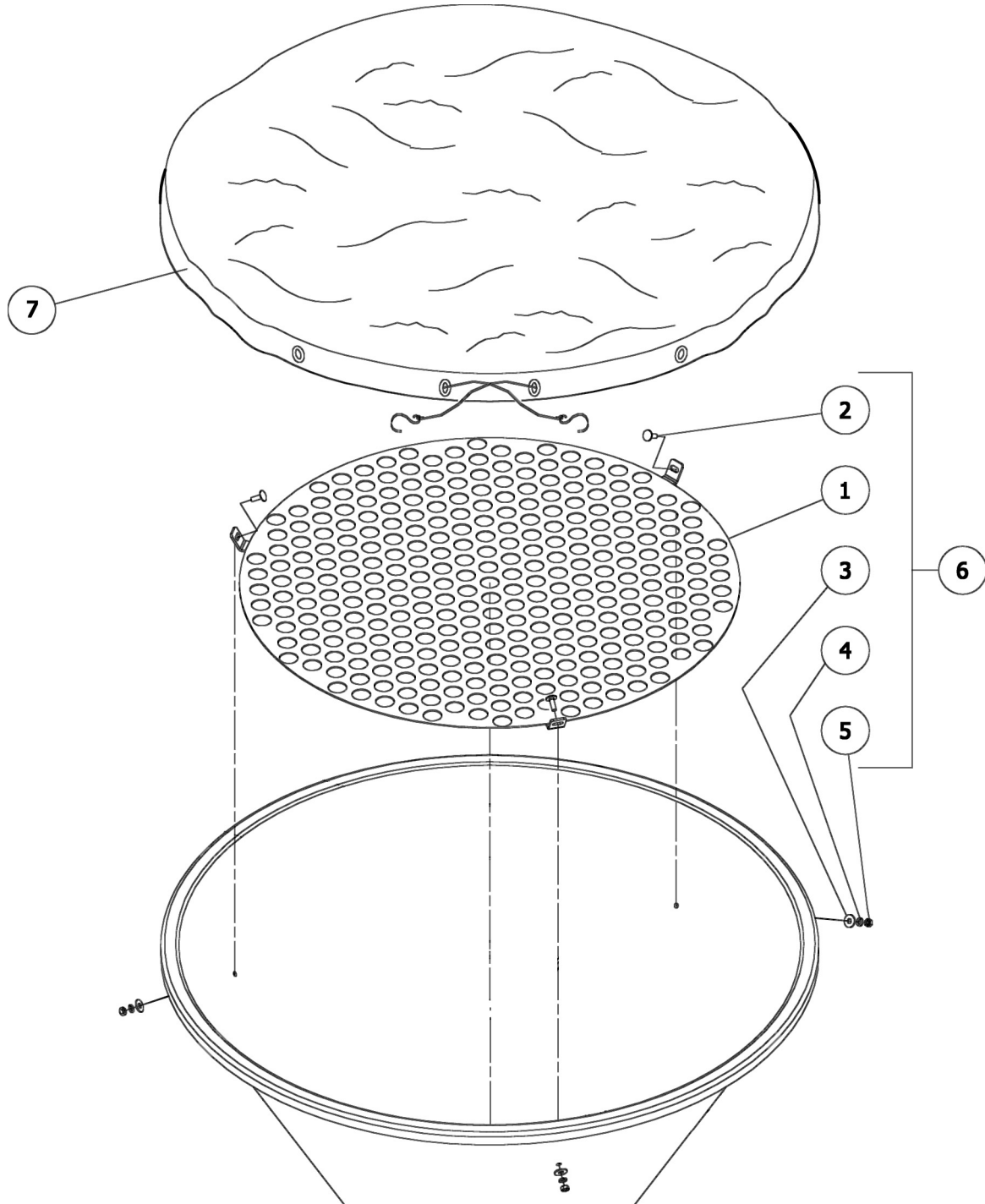

# Rotomec: Hop '300-500'

<b>N.</b>	<b>COD.</b>	<b>DESCRIZIONE</b>	<b>DESCRIPTION</b>	<b>DESCRIPTION</b>	<b>BESCHREIBUNG</b>	<b>N.</b>
1	0014430	Griglia di protezione	Filter grate	Grille de protection	Schutzgitter	1
2	501-663B	Vite TTQST M8x25	Bolt TTQST M8x25	Vis TTQST M8x25	Schraube TTQST M8x25	3
3	0014514	Rondella piana Ø8 Fascia larga	Flat washer Ø8 Large band	Rondelle plate Ø8 Bande large	Flache Scheibe Ø8 Breites Band	3
4	0003144	Rosetta elastica Ø8	Lock washer Ø8	Rondelle élastique Ø8	Sprenging Ø8	3
5	0046545	Dado M8	Nut M8	Ecrou M8	Mutter M8	3
6	0099913	Kit griglia di protezione	Filter grate complete	Kit grille de protection	Schutzgittersystem	1
7	0099722	Telo copri tramoggia (v.300)	Hopper cover (v.300)	Bâche de couverture de la trémie (v.300)	Trichtersbahn (v.300)	1
	0099723	Telo copri tramoggia (v.500)	Hopper cover (v.500)	Bâche de couverture de la trémie (v.500)	Trichtersbahn (v.500)	1

