

ROTOMECH

TORNADO 'RMD'

Falciaerba
Rotary cutter
Girobroyeur
Rotormäher

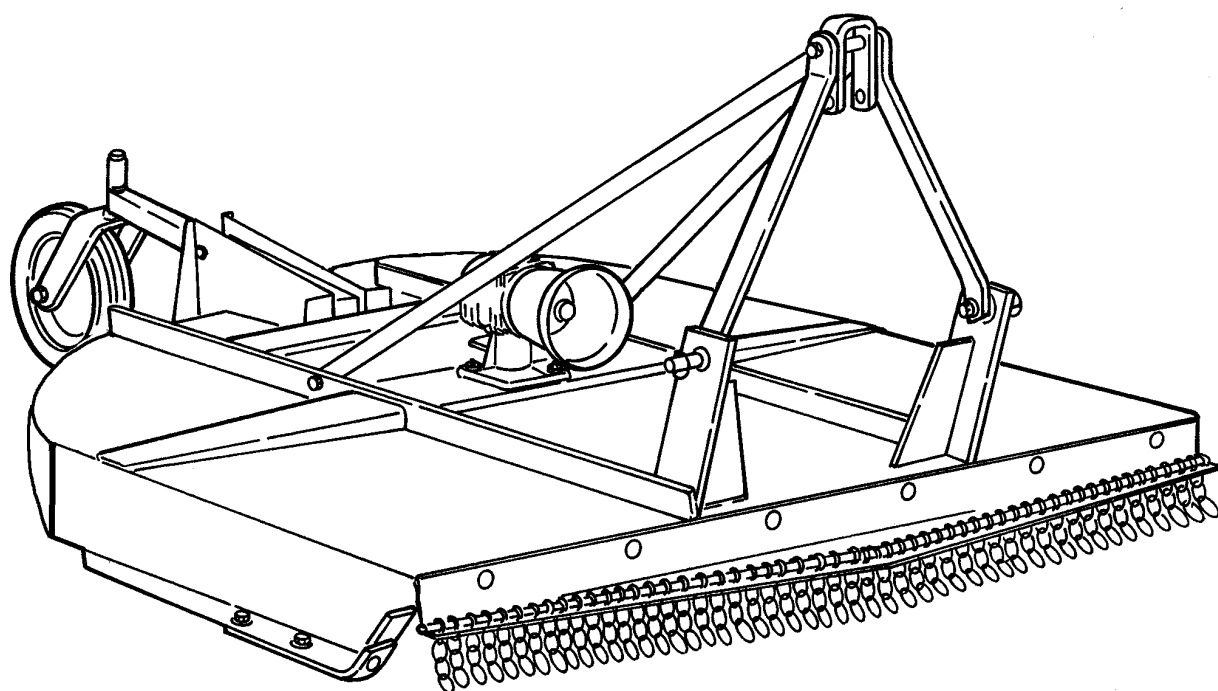

Rotomec: Tornado 'RMD'

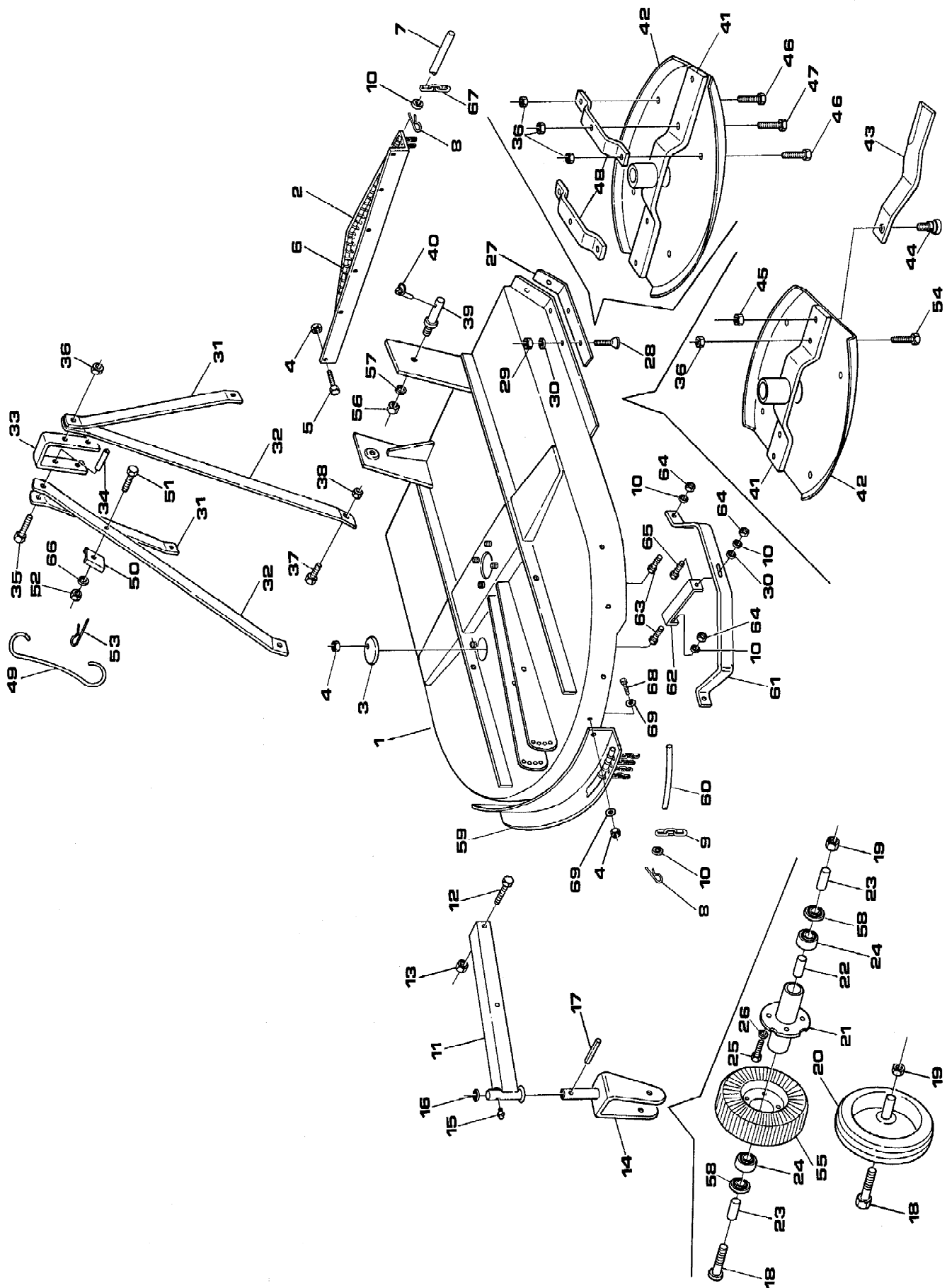

Rotomec: Tornado 'RMD'

N.	COD.	DESCRIZIONE	DESCRIPTION	DESCRIPTION	BESCHREIBUNG	N.
1	0160510	Telaio v.150	Frame v.150	Châssis v.150	Rahmen v.150	1
	0260510	Telaio v.180	Frame v.180	Châssis v.180	Rahmen v.180	1
2	0152715	Riparo anteriore v.150	Front shield v.150	Protection antérieure v.150	Vorderschutz v.150	1
	0260550	Riparo anteriore v.180	Front shield v.180	Protection antérieure v.180	Vorderschutz v.180	1
3	0005512	Coperchiella	Cover	Couvercle	Deckel	1
4	0030156	Dado M10	Nut M10	Ecrou M10	Mutter M10	-
5	0006349	Vite TE M10x20	Bolt TE M10x20	Vis TE M10x20	Schraube TE M10x20	-
6	0152718	Asta catene corta v.150	Short chain rod v.150	Rond porte-chaîne court v.150	Kurze Kettenstange v. 150	1
	0252718	Asta catene corta v.180	Short chain rod v.180	Rond porte-chaîne court v.180	Kurze Kettenstange v. 180	1
7	0152719	Asta catene lunga v.150	Long chain rod v.150	Rond porte-chaîne long v.150	Lange Kettenstange v. 150	1
	0252719	Asta catene lunga v.180	Long chain rod v.180	Rond porte-chaîne long v.180	Lange Kettenstange v. 180	1
8	0044156	Copiglia Ø4x25	Cotter pin Ø4x25	Goupille Ø4x25	Splint Ø4x25	3
9	0044158	Catena	Chain	Chaîne	Kette	-
10	0001077	Rosetta elastica Ø12	Spring washer Ø12	Rondelle élastique Ø12	Sprengring Ø12	14
11	0005523	Collegamento telaio ruota	Frame-wheel connection	Bras support roue	Rahmen-Radverbindung	1
12	0006566	Vite TE M16x100	Bolt TE M16x100	Vis TE M16x100	Schraube TE M16x100	2
13	0041165	Dado autobloccante M16	Locking nut M16	Ecrou autobloquant M16	Mutter M16	2
14	0005531	Forcella porta ruota	Wheel yoke	Fourche pour roue	Gabel für Rad	1
15	0001065	Ingrassatore	Grease fitting	Graisseur	Schmiernippel	1
16	0044128	Anello di spessoramento	Spacer washer	Anneau d'épaisseur	Distanzring	1
17	0005521	Spina elastica Ø10x45	Roll pin Ø10x45	Goupille élastique Ø10x45	Spannstift Ø10x45	1
18	0005506	Vite TE M20x180	Bolt TE M20x180	Vis TE M20x180	Schraube TE M20x180	1
19	0005508	Dado M20	Nut M20	Ecrou M20	Mutter M20	1
20	0005502	Ruotina	Wheel	Roue	Rad	1
21	0052882	Mozzo supporto ruota	Hub wheel	Moyeu roue	Radnabe	1
22	0052886	Distanziale interno	Inner spacer	Entretoise interne	Innendistanzstück	1
23	7900428	Distanziale esterno	Outer spacer	Entretoise externe	Außendistanzstück	2
24	0052889	Cuscinetto L44643-10	Bearing L44643-10	Roulement L44643-10	Lager L44643-10	2
25	0052891	Vite	Bolt	Vis	Schraube	4
26	0052892	Rosetta elastica	Spring washer	Rondelle élastique	Sprengring	4
27	0052709	Slitta laterale	Side skid	Patin latéral	Seitenschlitten	2
28	0044023	Vite TSPEI M12x30	Bolt TSPEI M12x30	Vis TSPEI M12x30	Schraube TSPEI M12x30	6
29	0030064	Dado M12	Nut M12	Ecrou M12	Mutter M12	6
30	0002265	Rondella piana Ø12	Flat washer Ø12	Rondelle plate Ø12	Flache Scheibe Ø12	6
31	0060620	Lama verticale	Top hitch support	Lame verticale	Vertikale Strebe	2
32	0160622	Lama inclinata v.150	Top hitch arm v.150	Lame inclinée v.150	Geneigte Strebe v.150	2
	0260622	Lama inclinata v.180	Top hitch arm v.180	Lame inclinée v.180	Geneigte Strebe v.180	2
33	0006828	Piastra superiore	Top hitch plate	Plaque supérieure	Obere Platte	1
34	0006829	Distanziale	Spacer	Entretoise	Distanzstück	1
35	0006834	Vite TE M16x150	Bolt TE M16x150	Vis TE M16x150	Schraube TE M16x150	1
36	0005581	Dado M16	Nut M16	Ecrou M16	Mutter M16	-
37	0001526	Vite TE M14x35	Bolt TE M14x35	Vis TE M14x35	Schraube TE M14x35	2
38	0030358	Dado M14	Nut M14	Ecrou M14	Mutter M14	2

Rotomec: Tornado 'RMD'

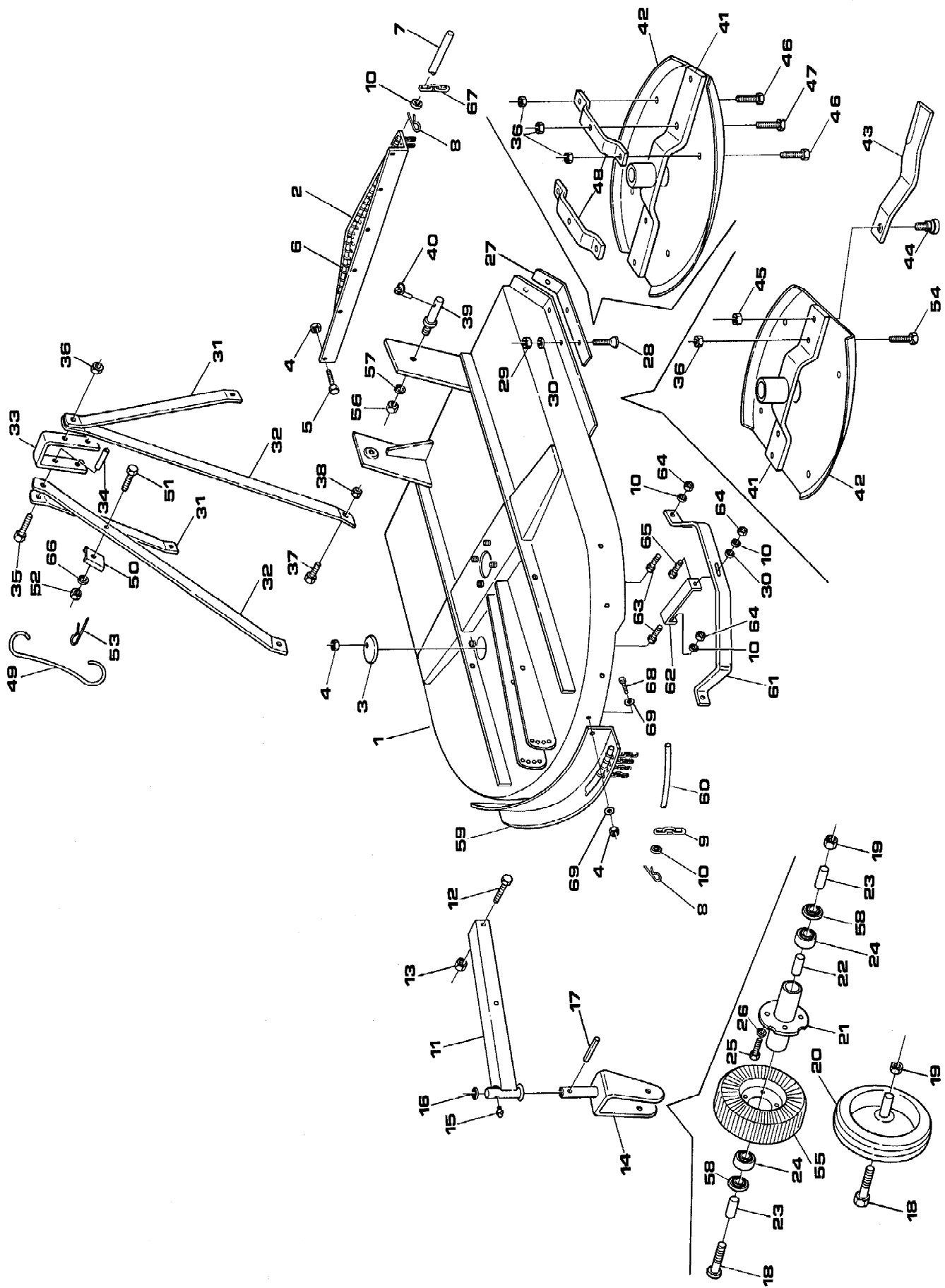

Rotomec: Tornado 'RMD'

N.	COD.	DESCRIZIONE	DESCRIPTION	DESCRIPTION	BESCHREIBUNG	N.
39	0060610	Spina attacco trattore	Hitch pin	Axe attache tracteur	Schlepperanschlußstift	2
40	0018266	Copiglia a spina	Lynch pin	Goupille	Klappsplint	2
41	0152846	Rotore v.150	Rotor v.150	Rotor v.150	Rotor v.150	1
	0252846	Rotore v.180	Rotor v.180	Rotor v.180	Rotor v.180	1
42	0052850	Protezione rotore v.150	Rotor protection v.150	Protection rotor v.150	Rotorschutz v.150	1
	0085160	Protezione rotore v.180	Rotor protection v.180	Protection rotor v.180	Rotorschutz v.180	1
43	0085152	Coltello	Blade	Couteau	Messer	2
44	0052861	Bullone di fissaggio	Fixing bolt	Vis de fixation	Befestigungsschraube	2
45	0005570	Dado autobloccante M27	Locking nut M27	Ecrou autobloquant M27	Mutter M27	2
46	0085168	Vite TE M16x30	Bolt TE M16x30	Vis TE M16x30	Schraube TE M16x30	4
47	0033218	Vite TE M16x55	Bolt TE M16x55	Vis TE M16x55	Schraube TE M16x55	2
48	0052858	Piatto di fissaggio	Fixing plate	Etrier	Fixierungsplatte	2
49	0052872	Gancio sostegno cardano	Driveline hook	Crochet	Kardangelenstützhaken	1
50	0022435	Fissaggio per gancio	Hook support	Arrêt pour levier	Fixierung für Haken	1
51	0046543	Vite TE M8x30	Bolt TE M8x30	Vis TE M8x30	Schraube TE M8x30	1
52	0001806	Dado M8	Nut M8	Ecrou M8	Mutter M8	1
53	0054422	Copiglia a molla Ø2	Cotter pin Ø2	Goupille ressort Ø2	Federsplint Ø2	1
54	0002365	Vite TE M16x50	Bolt TE M16x50	Vis TE M16x50	Schraube TE M16x50	2
55	0052895	Ruota lamellare	Laminated tire	Roue lamellaire	Lamellenrad	1
56	0005542	Dado M20	Nut M20	Ecrou M20	Mutter M20	2
57	0005351	Rosetta elastica Ø20	Spring washer Ø20	Rondelle élastique Ø20	Sprengring Ø20	2
58	0052888	Paraolio	Oil seal	Pare-huile	Simmering	2
59	0160571	Protezione posteriore v.150	Rear protection v.150	Protection postérieure v.150	Hinterer Schutz v.150	1
	0160572	Protezione posteriore c.ta v.150 dal 06/10	Rear protection complete v.150 since 06/10	Protection postérieure complète v.150 dès 06/10	Hinterer Schutz komplett v.150 ab 06/10	1
	0260571	Protezione posteriore v.180	Rear protection v.180	Protection postérieure v.180	Hinterer Schutz v.180	1
	0260572	Protezione posteriore c.ta v.180 dal 06/10	Rear protection complete v.180 since 06/10	Protection postérieure complète v.180 dès 06/10	Hinterer Schutz komplett v.180 ab 06/10	1
60	0160576	Asta catene v.150	Chain rod v.150	Rond porte-chaîne v.150	Kettenhaltestange v.150	1
	0160577	Asta catene v.150 dal 06/10	Chain rod v.150 since 06/10	Rond porte-chaîne v.150 dès 06/10	Kettenhaltestange v.150 ab 06/10	1
	0260576	Asta catene v.180	Chain rod v.180	Rond porte-chaîne v.180	Kettenhaltestange v.180	1
	0260577	Asta catene v.180 dal 06/10	Chain rod v.180 since 06/10	Rond porte-chaîne v.180 dès 06/10	Kettenhaltestange v.180 ab 06/10	1
61	0160611	Protezione posteriore v.150	Rear protection v.150	Protection postérieure v.150	Hinterer Schutz v.150	2
	0260611	Protezione posteriore v.180	Rear protection v.180	Protection postérieure v.180	Hinterer Schutz v.180	2
62	0060616	Piatto di fissaggio	Fixing plate	Etrier	Fixierungsplatte	2
63	0015255	Vite TE M12x30	Bolt TE M12x30	Vis TE M12x30	Schraube TE M12x30	6
64	0003038	Dado M12	Nut M12	Ecrou M12	Mutter M12	8
65	0023265	Vite TE M12x40	Bolt TE M12x40	Vis TE M12x40	Schraube TE M12x40	2
66	0003144	Rosetta elastica Ø8	Spring washer Ø8	Rondelle élastique Ø8	Sprengring Ø8	1
67	0060564	Catena	Chain	Chaîne	Kette	-
68	0033176	Vite TE M10x25	Bolt TE M10x25	Vis TE M10x25	Schraube TE M10x25	6
69	0002034	Rondella piana Ø10	Flat washer Ø10	Rondelle plate Ø10	Flache Scheibe Ø10	12

Rotomec: Tornado 'RMD', 540 rpm

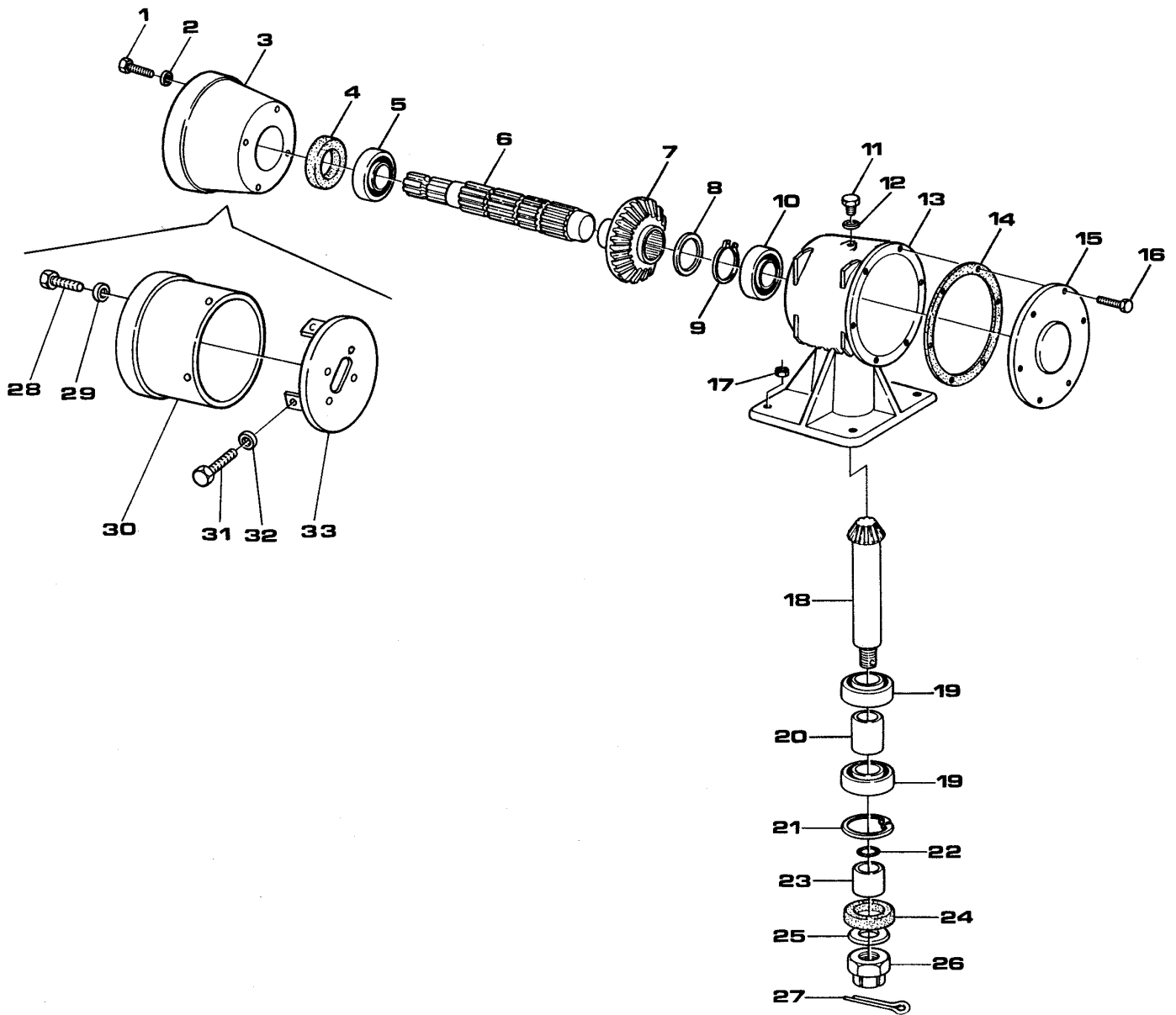

Rotomec: Tornado 'RMD', 540 rpm

N.	COD.	DESCRIZIONE	DESCRIPTION	DESCRIPTION	BESCHREIBUNG	N.
1	0092317	Vite TE M10x16	Bolt TE M10x16	Vis TE M10x16	Schraube TE M10x16	4
2	0002034	Rondella piana Ø10	Flat washer Ø10	Rondelle plate Ø10	Flache Scheibe Ø10	4
3	0008663	Protezione cardano	Shaft protection	Protection arbre	Kardangelenschutz	1
4	0002295	Paraolio 35.62.10	Oil seal 35.62.10	Pare-huile 35.62.10	Simmering 35.62.10	1
5	0007172	Cuscinetto 30207	Bearing 30207	Roulement 30207	Lager 30207	1
6	0005556	Albero P.D.F.	Input shaft	Arbre P.D.F.	Zapfwelle	1
7	0052792	Corona conica	Ring gear	Couronne conique	Tellerrad	1
8	0034196	Anello di spessoramento	Spacer washer	Anneau d'épaisseur	Distanzring	1
9	0042122	Seeger esterno Ø35	Outer snap ring Ø35	Circlip externe Ø35	Außenseegerring Ø35	1
10	0044217	Cuscinetto 30305	Bearing 30305	Roulement 30305	Lager 30305	1
11	0001107A	Sfiatatoio	Breather cap	Bouchon d'huile	Gehäuseentlüfter	1
12	0006691	Guarnizione	Gasket	Joint d'étanchéité	Dichtung	1
13	0006658	Scatola ingranaggi	Gearbox	Boîtier	Getriebekasten	1
	0006998	Scatola ingranaggi - da 02/02	Gearbox - 02/02	Boîtier - 02/02	Getriebekasten - 02/02	1
14	0030193	Guarnizione sp. ² / ₁₀	Gasket ² / ₁₀	Joint d'étanchéité ² / ₁₀	Dichtung ² / ₁₀	-
	0130193	Guarnizione sp. ⁵ / ₁₀	Gasket ⁵ / ₁₀	Joint d'étanchéité ⁵ / ₁₀	Dichtung ⁵ / ₁₀	-
15	0006656	Coperchiella corona	Gear cover	Couvercle couronne	Kranzhaube	1
16	0006349	Vite TE M10x20	Bolt TE M10x20	Vis TE M10x20	Schraube TE M10x20	6
17	0030064	Dado M12	Nut M12	Ecrou M12	Mutter M12	4
18	0052793	Pignone conico	Pinion gear	Pignon conique	Kegelrad	1
19	0012149	Cuscinetto 6208	Bearing 6208	Roulement 6208	Lager 6208	2
20	0006687	Distanziale pignone	Spacer	Entretoise pignon	Ritzeldistanzstück	1
21	0001154	Seeger interno Ø80	Inner snap ring Ø80	Circlip interne Ø80	Innenseegerring Ø80	1
22	0005630	Guarnizione OR 144	Gasket OR 144	Joint d'étanchéité OR 144	Dichtung OR 144	1
23	0052808	Distanziale	Spacer	Entretoise	Distanzstück	1
24	0005578	Paraolio 55.80.10 BASL	Oil seal 55.80.10 BASL	Pare-huile 55.80.10 BASL	Simmering 55.80.10 BASL	1
25	0066039	Rondella piana Ø30	Flat washer Ø30	Rondelle plate Ø30	Flache Scheibe Ø30	1
26	0003055	Dado M30	Nut M30	Ecrou M30	Mutter M30	1
27	0005638	Copiglia Ø5x50	Cotter pin Ø5x50	Goupille Ø5x50	Splint Ø5x50	1
28	0006349	Vite TE M10x20	Bolt TE M10x20	Vis TE M10x20	Schraube TE M10x20	4
29	0030157	Rondella piana Ø10	Flat washer Ø10	Rondelle plate Ø10	Flache Scheibe Ø10	4
30	0011207	Protezione cardano	Shaft protection	Protection arbre	Kardangelenschutz	1
31	0011210	Vite TC M6x12	Bolt TC M6x12	Vis TC M6x12	Schraube TC M6x12	4
32	0011209	Rondella piana Ø6	Flat washer Ø6	Rondelle plate Ø6	Flache Scheibe Ø6	4
33	0011201	Supporto protezione	Protection support	Palier protection	Schutzabdeckungsauflage	1
	0500616	Gruppo scatola	Gearbox	Boîtier	Gehäusegruppe	
	0500644	Gruppo scatola - da 02/02	Gearbox - 02/02	Boîtier - 02/02	Gehäusegruppe - 02/02	

Rotomec: Tornado 'RMD'

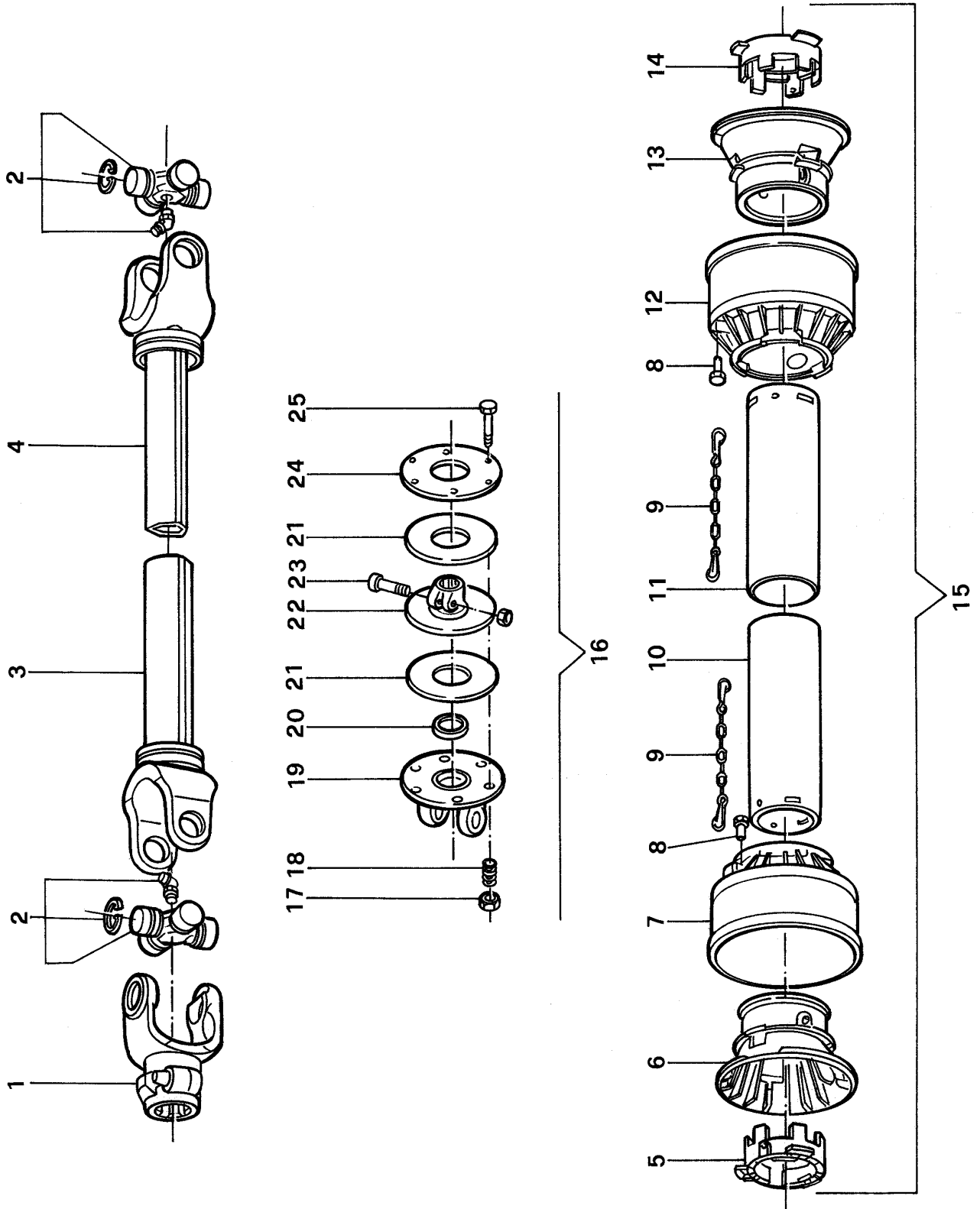

Rotomec: Tornado 'RMD'

N.	COD.	DESCRIZIONE	DESCRIPTION	DESCRIPTION	BESCHREIBUNG	N.
1	1024010C	Forcella P.D.F.	PTO Yoke	Fourche P.D.F.	Aufsteckgabel	1
2	1004020C	Crociera	Cross & Bearing	Croisillon	Kreuzgelenk	2
3	1944058NC	Tubo esterno v.150	Outer tube v.150	Tube externe v.150	Außenrohr v.150	1
	1944073NC	Tubo esterno v.180	Outer tube v.180	Tube externe v.180	Außenrohr v.180	1
4	1954060NC	Tubo interno v.150	Inner tube v.150	Tube interne v.150	Innenrohr v.150	1
	1954075NC	Tubo interno v.180	Inner tube v.180	Tube interne v.180	Innenrohr v.180	1
5	1784210C	Anello tubo esterno	Outer locking ring	Anneau externe	Außenrohrring	1
6	1784201C	Controcuffia tubo esterno	Outer tube rigid cone	Contre coiffe externe	Außenrohrgegentopf	1
7	1784203C	Cuffia esterna	Outer cone	Coiffe externe	Außenschutztopf	1
8	1784212C	Spina di bloccaggio	Pin	Goupille	Haltestift	2
9	1006065C	Catenella	Chain	Chaîne	Kette	2
10	1773056C	Tubo protezione esterna v.150	Female tube shield v.150	Tube protection femelle v.150	Außenschutzrohr v.150	1
	1773071C	Tubo protezione esterna v.180	Female tube shield v.180	Tube protection femelle v.180	Außenschutzrohr v.180	1
11	1872056C	Tubo protezione interna v.150	Male tube shield v.150	Tube protection mâle v.150	Innenschutzrohr v.150	1
	1872071C	Tubo protezione interna v.180	Male tube shield v.180	Tube protection mâle v.180	Innenschutzrohr v.180	1
12	1784204C	Cuffia esterna	Outer cone	Coiffe externe	Außenschutztopf	1
13	1784202C	Controcuffia tubo interno	Inner tube rigid cone	Contre coiffe interne	Innenrohrgegentopf	1
14	1784211C	Anello tubo interno	Inner locking ring	Anneau interne	Innenrohrring	1
15	90SC4056C	Protezione completa v.150	Complete shielding v.150	Protection complète v.150	Kompletter Schutz v.150	1
	90SC4071C	Protezione completa v.180	Complete shielding v.180	Protection complète v.180	Kompletter Schutz v.180	1
16	241002E	Frizione completa	Complete slip clutch	Embrayage complet	Komplette Kupplung	1
17	0014106	Dado autobloccante D.10	Locking nut D.10	Ecrou autobloquant D.10	Mutter D.10	8
18	014022E	Molla	Spring	Ressort	Feder	8
19	014017E	Forcella frizione	Yoke-slip clutch	Fourche	Kupplungsgabel	1
20	015020E	Bronzina	Bushing	Coussinet en bronze	Bronzelager	1
21	014019E	Ferodo	Friction disc	Disque friction	Bremsbelag	2
22	014018E	Corpo frizione	Body-slip clutch	Corps friction	Kupplungskörper	1
23	000502E	Vite e dado 12x65	Bolt and nut 12x65	Vis et écrou 12x65	Schraube und Mutter 12x65	1
24	014020E	Flangia frizione	Outer flange	Plaque	Kupplungsflansch	1
25	0015236	Vite TE 10x80	Bolt TE 10x80	Vis TE 10x80	Schraube TE 10x80	8
	0500461	Cardano v.150	PTO shaft v.150	Arbre à cardan v.150	Kardangelenk v.150	
	0500462	Cardano v.180	PTO shaft v.180	Arbre à cardan v.180	Kardangelenk v.180	

