

# ROTOMECH

## Operator's Manual

### TORNADO

Rotary Cutter  
Series 'RMD'

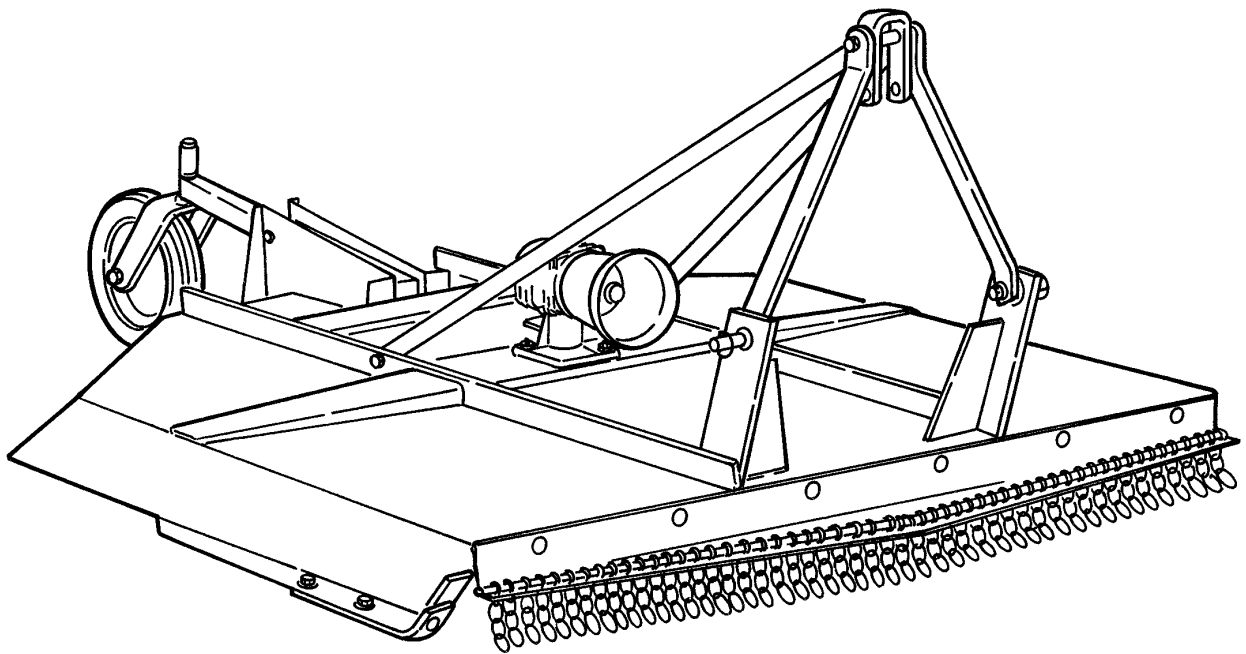

The operator's manual is a technical service guide and must always accompany the machine.

**MERMDEB**

# SAFETY

Take note! This safety alert symbol found throughout this manual is used to call your attention to instructions involving your personal safety and the safety of others. Failure to follow these instructions can result in injury or death.



*This symbol means:*  
**ATTENTION!**  
**BECOME ALERT!**  
**YOUR SAFETY IS INVOLVED!**

## Signal Words

Note the use of the signal words DANGER, WARNING and CAUTION with the safety messages. The appropriate signal words for each has been selected using the following guidelines:



**DANGER:** indicates an imminently hazardous situation that, if not avoided, will result in death or serious injury.



**WARNING:** indicates a potentially hazardous situation that, if not avoided, could result in death or serious injury, and includes hazards that are exposed when guards are removed. It may also be used to alert against unsafe practices.



**CAUTION:** indicates a potentially hazardous situation that, if not avoided, may result in minor or moderate injury.

# ROTOMECH

## Operator's Manual

### TORNADO

Rotary Cutter  
**Series 'RMD'**

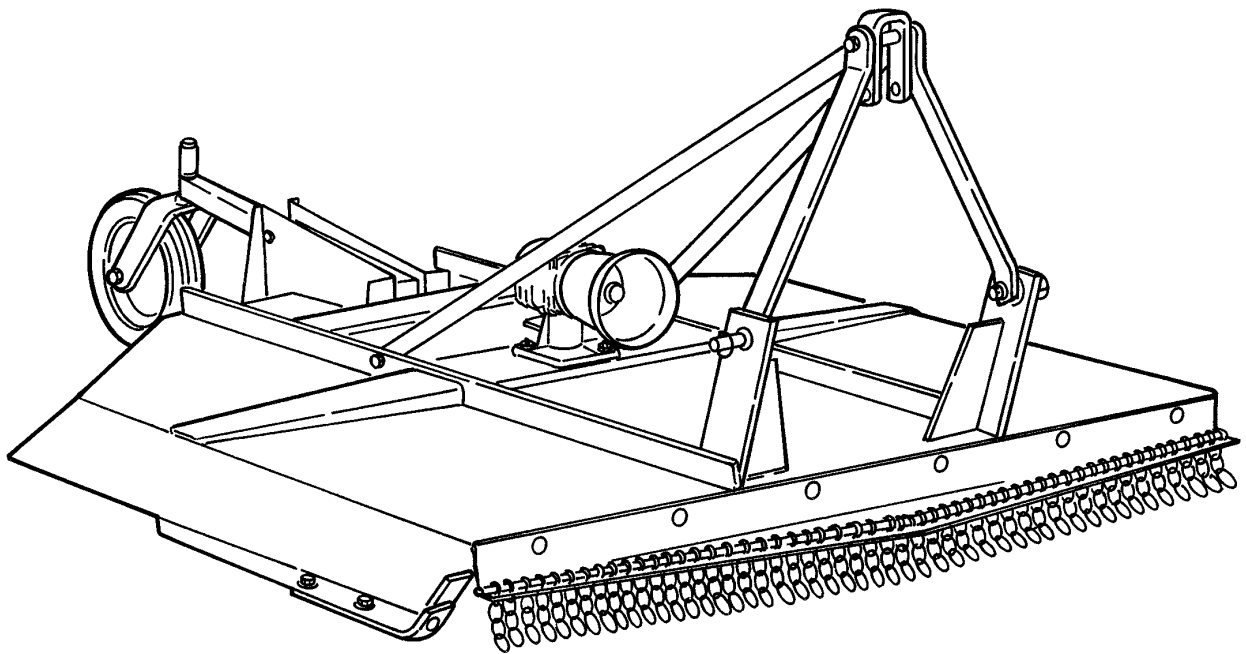

The operator's manual is a technical service guide and must always accompany the machine.

# INDEX

<b>1 - GENERAL INFORMATION</b>	5
1.01 - General	5
1.02 - Model and Serial Number ID	5
<b>2 - SAFETY PRECAUTIONS</b>	7
2.01 - Preparation	7
2.02 - Starting and Stopping	8
2.03 - Messages and Signs	8
<b>3 - OPERATION</b>	10
3.01 - Operational Safety	10
3.02 - Set-up	12
3.03 - Cutting Height Adjustment	12
3.04 - Pre-Operational Check	13
3.05 - Attaching to the Tractor	14
3.06 - Start Up	14
3.07 - Working Speed	16
3.08 - Uneven Terrain	16
3.09 - Removing Cutter from the Tractor	17
<b>4 - MAINTENANCE</b>	19
4.01 - Maintenance Safety	19
4.02 - Service	20
4.03 - Blade Maintenance	21
4.04 - Rotor & Stump Jumper Assembly	23
4.05 - Driveline	24
4.06 - Safety Slip Clutch	25
4.07 - Transport	25
<b>5 - REPAIR PROCEDURES</b>	27
5.01 - Gearbox	27
5.02 - Suggested Spare Parts	27
5.03 - Storage	27
<b>6 - TROUBLESHOOTING</b>	28
<b>7 - PRE-DELIVERY CHECKLIST</b>	29
<b>8 - WARRANTY</b>	30

# 1 - GENERAL INFORMATION

Thank you and congratulations for having chosen our implement. Your new rotary cutter is a technologically advanced machine constructed of high quality, sturdy, components that will fulfil your working expectations.

Read this manual carefully. It will instruct you on how to operate and service your machine safely and correctly. Failure to do so could result in personal injury and/or equipment damage.

## 1.01 - General





**CAUTION:** all hardware is metric. Only metric tools should be used. Other tools that do not fit properly can slip and cause injury.



**CAUTION:** right hand and left hand sides of the implement are determined by facing in the direction the implement will travel when going forward (see fig. 2).

## 1.02 - Model and Serial Number ID

Attached to the frame is an ID plate showing the model and serial number (see below). Record your implement model and serial number in the space provided below. Your dealer needs this information to give you prompt, efficient service when you order parts.

 <b>ROTOMECC</b> S.p.A. 37054 NOGARA (VERONA) ITALY PH.: 39.(0).442.510400 r.a.		
MOD.	N.	
KW.	KG.	YEAR

Carefully read the warranty section<sup>1</sup> detailing coverage and limitations of this warranty. **Warranty** is provided for customers who operate and maintain their equipment as described in this manual. Warranty registration is accomplished by the dealer completing and forwarding the **Warranty Registration Form** to the Company, along

<sup>1</sup> See chapter 8 - Warranty.

with a copy of the dealer's invoice. It is in your best interest to insure that this has been done.

Warranty does not cover the following:

1. cleaning, transporting, mailing and service call charge.
2. Normal wear items such as blades, bearings, wheels, drivelines, shear pin, slip clutches etc.
3. Depreciation or damage caused by normal wear, accidents, improper maintenance, improper protection or improper use.
4. The use of non original spare parts and accessories.

Your Authorised Company Dealer has genuine parts in stock. **Only these approved replacement parts should be used.**

This limited warranty covers defective material and workmanship. The cost of normal maintenance or repairs for accidents or improper use and related labour will be borne by the owner.

## 2 - SAFETY PRECAUTIONS

Safety is the primary concern in the design and manufacture of our products. Unfortunately our efforts to provide safe equipment can be wiped out by a single careless act of an operator.

In addition to the design and configuration of equipment, hazard control and accident prevention are dependent upon the awareness, concern, prudence and proper training of personnel involved in the operation, transport, maintenance and storage of equipment.

It is the operator's responsibility to read and understand all safety and operating instructions in the manual and to follow these.

Allow only properly trained personnel to operate the rotary cutter. Working with unfamiliar equipment can lead to careless injuries. Read this manual, and the manual for your tractor, before assembly or operating, to acquaint yourself with the machines. It is the cutter owner's responsibility, if this machine is used by any person other than yourself, is loaned or rented, to make certain that the operator, prior to operating, reads and understands the operator's manuals and is instructed in safe and proper use.

### 2.01 - Preparation



1. Before operating equipment read and understand the operator's manual and the safety signs (**see fig. 2**).
2. Thoroughly inspect the implement before initial operation to assure that all packaging materials, i.e. wires, bands, and tape have been removed.
3. Personal protection equipment including hard hat, safety glasses, safety shoes, and gloves are recommended during assembly, installation, operation, adjustment, maintaining and/or repairing the implement.
4. Operate the rotary cutter only with a tractor equipped with an approved Roll-Over-Protective-System (ROPS). Always wear your seat belt. Serious injury or even death could result from falling off the tractor.
5. Clear area to be cut of stones, branches or other debris that might be thrown, causing injury or damage.
6. Operate only in daylight or good artificial light.
7. Ensure cutter is properly mounted, adjusted and in good operating condition.
8. Ensure that all safety shielding and safety signs are properly installed and in good condition.

## 2.02 - Starting and Stopping



1. Be sure that no one is near the machine prior to engaging or while the machine is working.
2. Be sure the tractor is in "Neutral" before starting engine.
3. Cutter operating power is supplied from tractor PTO. Refer to your tractor manual for PTO engagement and disengagement instructions. Always operate PTO at 540 rpm. Know how to stop the tractor and cutter quickly in case of an emergency.
4. When engaging PTO, the engine rpm should always be low. Once engaged and ready to start cutting, raise PTO speed to 540 rpm and maintain throughout cutting operation.
5. Check the tractor master shield over the PTO stub shaft. Make sure it is in good condition and fastened securely to the tractor. Purchase a new shield if old shield is damaged or missing.
6. After striking an obstacle, disengage the PTO, shut the tractor down and thoroughly inspect for damage before restarting.
7. Never engage the PTO until the rotary cutter is in the down position and resting on the ground. Never raise the rotary cutter until all blades have come to a complete stop.

## 2.03 - Messages and Signs



1. Read and adhere to all safety and operating decals on this machine (**see fig. 2**).
2. Before dismounting tractor: allow moving parts to stop, stop engine, set brake and remove the key of unattended equipment.
3. Keep away from rotating blades and driveline.
4. Keep guards and shields in place and in good condition.
5. Do not mow with bystanders in area.
6. Allow no riders on tractor or cutter.
7. Allow moving parts to stop before repair.
8. Securely support cutter before working underneath.

Additional warning and operating decals are available at no extra charge. Please specify model and serial number when ordering.



**Fig. 2 - Safety decals; replace immediately if damaged.**

- 1. read carefully this manual**
- 2. before maintenance operations, disengage PTO and shut tractor down**
- 3. 540 rpm PTO only**
- 4. keep away from rotating driveline**
- 5. keep away: thrown objects**
- 6. never allow passengers**
- 7. keep all shields in place**
- 8. keep away from rotating blades**
- 9. keep shields in place: moving parts**

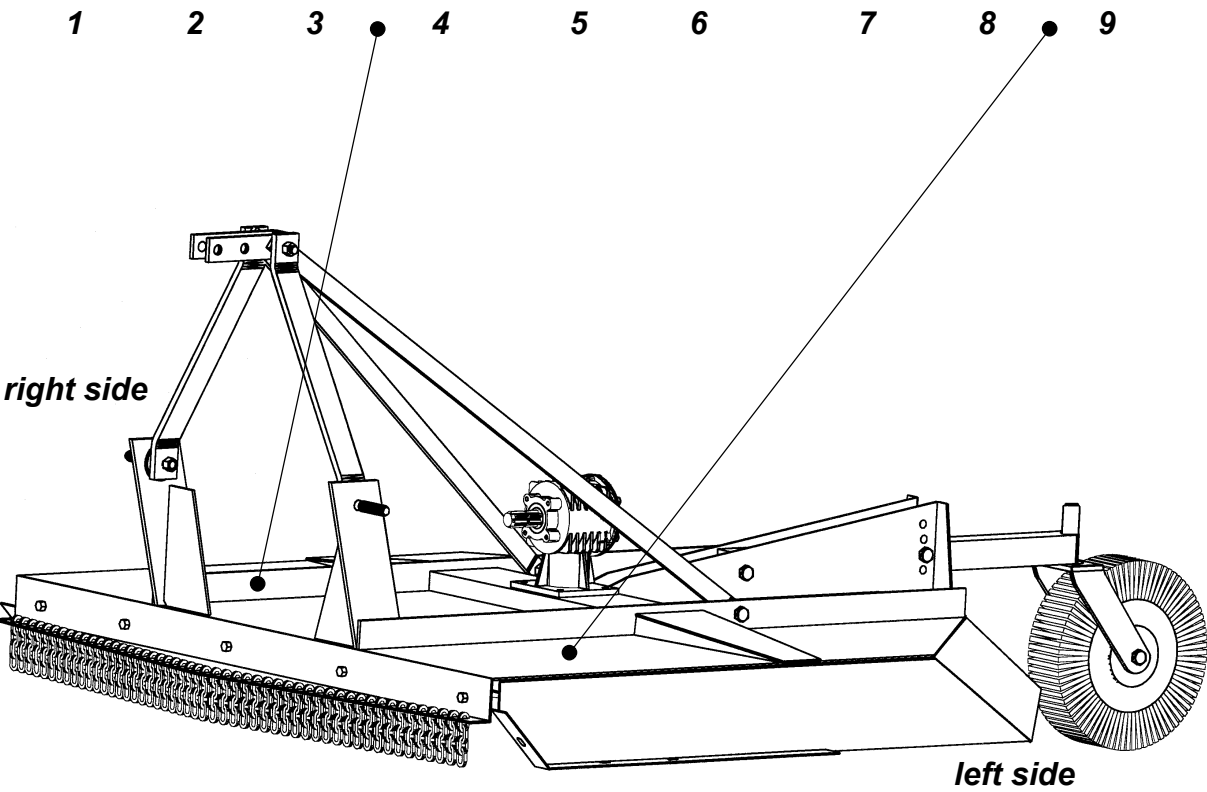
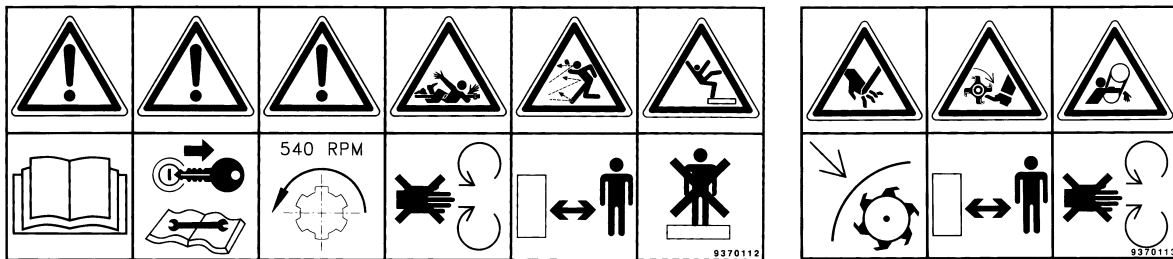

## 3 - OPERATION

You have purchased a rotary cutter which is solid, dependable, and built to last. Ideal for farms, industrial sites, airports, highways, hospital grounds, and more.

Handles the tallest grass and your toughest mowing assignment including bushes. Can be used also for chopping wheat, cornstalks, sunflowers, artichokes, potatoes, etc. The residue is pulverised for easy incorporation.

The rotary cutter Tornado RMD comes in working width of 150 and 180 cm. for 40 to 80 HP. The standard PTO runs at 540 rpm. On your cutter, the tractor PTO transmits its power through a driveline to a speed multiplier gearbox. The pinion gear shaft of the gearbox transmits the power to the blades holder always protected by a stump guard. The balanced rotor is equipped with 2 free swing spring steel blades. It comes with a cutting height control tail wheel.

### 3.01 - Operational Safety



**CAUTION:** our rotary cutters are designed considering safety as the most important target and are the safest available in today's market. Unfortunately, human carelessness can override the safety features built into our machines. Injury prevention and work safety, aside from the features on our cutters, is very much due to the responsible use of the equipment. It must always be operated prudently following with great care, the safety instructions laid out in this manual.



1. The use of this equipment is subject to certain hazards which cannot be prevented by mechanical means or product design. All operators of this equipment must read and understand this entire manual, paying particular attention to safety and operating instructions, prior to using.
2. Do not operate the tractor and cutter when you are tired, sick or when using medication.
3. Keep all helpers and bystanders at least several meters from a rotary cutter. Only properly trained people should operate this machine.
4. When this machine is operated in populated areas where thrown objects could injure persons or property, standard equipment safety chain shielding (which is designed to reduce the possibility of thrown objects) must be installed.
5. The majority of accidents involve entanglements on the driveline, injury of bystanders by objects thrown by the rotating blades, and operators being knocked off the tractor by low hanging limbs and then being run over by the cutter. Accidents are most likely to occur with machines that are loaned or rented to someone who has not read the operator's manual and is not familiar with a rotary cutter.

6. Always stop the tractor, set brake, shut off the tractor engine, remove the ignition key, lower implement to the ground and allow blades to come to a complete stop before dismounting tractor. Never leave equipment unattended with the tractor running.
7. Never place hands or feet under cutter's deck with tractor engine running or before you are sure all motion has stopped. Stay clear of all moving parts.
8. Do not allow riders on the cutter or tractor at any time. There is no safe place for riders.
9. Do not operate unless all personnel, livestock and pets are several meters away to prevent injury by thrown objects.
10. Before backing up, disengage the cutter and look behind carefully.
11. Install and secure all guards and shields before starting or operating.
12. Keep hands, feet, hair and clothing away from moving parts.
13. This rotary cutter is designed for use only on tractors with 540 rpm power take off.
14. Never operate tractor and cutter under trees with low hanging limbs. Operators can be knocked off the tractor and then run over by the rotating blades.
15. The rotating parts of this machine have been designed and tested for rugged use. However, they could fail upon impact with heavy, solid objects such as steel guard rails and concrete abutments. Such impact could cause the broken objects to be thrown outward at very high velocities. To reduce the possibility of property damage, serious injury, or even death, never allow the cutting blades to contact such obstacles.
16. Frequently check blades. They should be sharp, free of nicks and cracks and securely fastened.
17. Stop cutter immediately upon striking an obstruction. Turn engine off, remove key, inspect and repair any damage before resuming operation.
18. Stay alert for holes, rocks and roots in the terrain and other hidden hazards. Keep away from drop-offs.
19. Use extreme care and maintain minimum ground speed when transporting on hillside, over rough ground and when operating close to ditches or fences. Be careful when turning sharp corners.
20. Reduce speed on slopes and sharp turns to minimise tipping or loss of control. Be careful when changing directions on slopes. Do not start or stop suddenly on slopes. Avoid operation on steep slopes.
21. When using a unit, a minimum 20% of tractor and equipment weight must be on tractor front wheels. Without this weight, tractor could tip over, causing personal injury or death. The weight may be attained with a front end loader, front wheel weights, ballast in tires or front tractor weights. When attaining a minimum 20% of tractor and equipment weight on the front wheels, you must not exceed the ROPS weight certification. Weigh the tractor and equipment. Do not guess or estimate!
22. Inspect the entire machine periodically<sup>2</sup>. Look for loose fasteners, worn or broken parts, and leaky or loose fittings.
23. Use only the driveline supplied with the equipment. Do not use it if it is missing any shield or safety protection.

---

<sup>2</sup> See chapter 4 - Maintenance.

24. Pass diagonally through sharp dips and avoid sharp drops to prevent "hanging up" tractor and implement.
25. Avoid sudden starts and stops while travelling up or downhill.
26. Always cut down slopes; never across the face. Avoid operation on steep slopes. Slow down on sharp turns and slopes to prevent tipping and or loss of control.

### 3.02 - Set-up

**Notice to dealer:** pre-delivery set-up and service including lubrication is the responsibility of the authorised dealer. It is up to you to assure that the machine is in perfect condition and ready to be used. It is your responsibility to ensure that the customer is aware of all safety aspects and operational procedures for the cutter. You must also fill out the Pre-delivery Checklist prior to delivering the machine<sup>3</sup>.



**CAUTION:** stand clear of bands when cutting as they could be under sufficient tension to cause them to fly loose. Take care in removing bands and wire, they often have extremely sharp edges and cut very easy.

### 3.03 - Cutting Height Adjustment



**WARNING:** keep hands and feet away from moving blades.  
**Be sure tractor engine is off, parking brake is locked, and key is removed before making any adjustments.**  
**Never rely on the tractor lift system. Install blocks or stands under the cutter deck to prevent it from falling.**

The cutting height is the distance from the blades to the ground which is determined by the position of the tail wheel.

To adjust the cutting height, do the following:

1. remove the bolt holding the wheel arm (**see fig. 3**).
2. Position the wheel to the desired height and replace the bolt in the appropriate hole. The wheel arm holder has four hole positions. Of the four holes, the upper hole is for the lowest cutting height, and the lower hole, the one closest to the ground, is for the highest.
3. Properly tighten the bolt.

---

<sup>3</sup> See chapter 7 - Pre-delivery Checklist.

**IMPORTANT:** very low cutting heights should be avoided. Damaging shock loads occur when the blades strike the ground repeatedly. This can cause damage to the cutter.

The cutting height varies from 25 to 235 mm. (1" to 9").

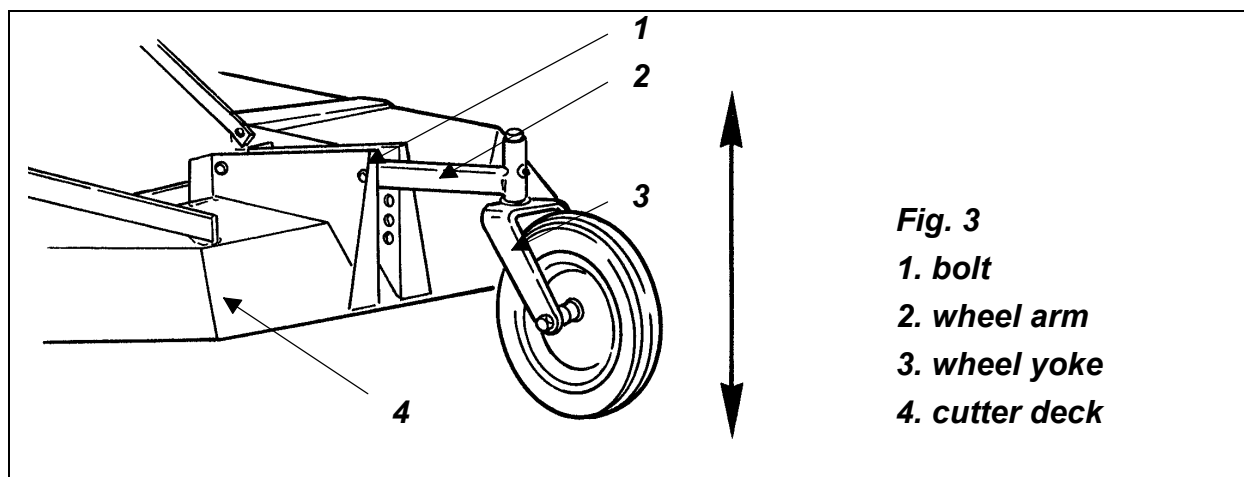

### 3.04 - Pre-Operational Check

Check each of the following carefully prior to engaging the equipment:

1. the spindle bearing has been greased.
2. The oil in the gearbox.
3. The driveline cross & bearings have been greased.
4. No wrappings or foreign objects are around the rotor, blades, or driveline.
5. The blades are properly installed and the blade bolts properly torqued<sup>4</sup>.
6. All hardware is tight.
7. The tractor, to ensure correct direction of PTO and rpm speed.
8. All safety shields and guards are in their place and tightly attached.
9. No people or animals are in the work area.



**WARNING:** stay clear of rotating driveline. Entanglement in rotating driveline can cause serious injury. Disengage PTO, engage parking brake or place transmission in "Park", shut off the tractor and remove the key before working around hitch, attaching or detaching driveline, making adjustments, servicing or cleaning the machine.

<sup>4</sup> See table 1, page 18.

### 3.05 - Attaching to the Tractor

Only use this model implement with tractors in the correct power range<sup>5</sup>.



**CAUTION:** check the tractor PTO rpm and its direction of rotation to ensure that they correspond to what is indicated on the machine.



**WARNING:** disengage PTO, wait for all movement from the implement and tractor to stop, engage parking brake or place transmission in "Park", shut off the tractor and remove the key before attaching the implement to the tractor.



**DANGER:** tractor-implement combinations can create unstable unions with a chance of roll over. If necessary, front weights need to be added to the tractor in order to maintain balance. Always ensure that the tractor tire pressure is correct according to the tractor operator's manual.

**To attach the cutter to the tractor do the following:**

1. back the tractor up to the machine in order to slip the tractor hitch arms over the hitch pins bolted to the cutter hitch arms. **Turn off the tractor engine.** Secure them in place with the lynch pins. **Failure to ensure a secure coupling of the implement to the tractor can cause injury and damage to the implement or tractor.**
2. Adjust the tractor sway blocks or chains to remove all side movement.
3. Attach the top link. Adjust tractor top link to allow the cutter to follow the ground contour and yet remain as level as possible when raised to transport position.
4. Install the shielded driveline to the tractor by first lining up the splines and depressing the snap pin. Push the yoke onto the PTO shaft as far as it will go. Release the pin and pull back slowly until the pin clicks in place. Repeat this operation on the implement end.
5. Attach the driveline chains to the tractor and to the machine to keep the driveline protection from turning. The chains should not be too tight.

### 3.06 - Start Up



**CAUTION:** the cutter must always be lowered to the ground before starting tractor engine or engaging PTO lever.

---

<sup>5</sup> See table 2, page 18.

Lower the implement with the tractor rockshaft control lever until the deck is horizontal to the ground. If the cutting height is not correct, change the setting using the tail wheel<sup>6</sup>. The deck should be horizontal to the ground when cutting. With the engine idling, slowly engage the PTO drive. Move the throttle lever until the PTO speed indicated on the cutter is obtained.

The machine is normally set for a PTO speed of 540 rpm. Other special versions are available, upon request, for other speeds.

Shift the transmission to a slow speed gear and start forward, increase the ground speed by shifting upward until the desired speed is obtained. Do not mow in reverse unless absolutely necessary and only after careful observation of the area behind the rotary cutter.



**CAUTION: do not operate this implement at a PTO speed or direction of rotation other than that shown on the cutter. Serious damage can occur to the machine and/or the operator.**

Before starting to mow, never forget that the **operator is responsible** for the following:

1. safe and correct driving of the tractor and cutter.
2. To learn precise safe operating procedures for both the tractor and the cutter.
3. To ensure all maintenance and lubrication has been performed on the cutter.
4. To have read and understood all safety aspects for the cutter in the operator's manual.
5. To have read and understood all safety decals on the machine.
6. Checking the condition of the blades. Worn or damaged blades should be changed before starting<sup>7</sup>.
7. Checking to ensure that the cutting edge is the leading edge of the blade.
8. Checking that there is no wire, weed, grass or other material wrapped around blades.
9. Checking to see if front weights need to be added to the tractor in order to maintain balance.
10. Checking the tractor tires for the proper pressure in accordance to the tractor operator's manual.
11. **Checking that the PTO shield and all other shielding are on the machine and securely in place.**
12. Making sure the proper attire is worn. Avoiding loose fitting clothing which can become entangled. Wearing sturdy, tough-soled work shoes and protective equipment for eyes, hands, ears and head. Never operate tractor or implement in bare feet, sandals or sneakers.
13. Checking area for stones, branches and other debris that might be thrown.
14. Ensuring proper lighting is available, sunlight or good artificial lighting.

---

<sup>6</sup> See section 3.03 - Cutting Height Adjustment.

<sup>7</sup> See section 4.03 - Blade Maintenance, for details.

### 3.07 - Working Speed

The mowing speed depends on ground conditions, tractor HP, mowing height, and grass thickness. Only a test run will enable you to gauge the optimal working speed for your conditions.

Under most conditions a 4 to 10 km per hour (2 to 6 mph) ground speed is best.

In order to obtain the best cut possible, always keep the tractor rpm up to the speed indicated on the cutter. When increasing or decreasing mowing ground speed, always use gear selection, not engine speed. This will maintain the constant maximum blade speed necessary for a clean cut.



**WARNING:** never operate without all shields on the machine and securely in place. The cutter blades can throw objects tens of meters (hundreds of feet) which could result in personal or property damage.

Pick up all rocks and other debris before mowing.

Enter new areas carefully. Cut grass higher at first, allowing the machine to clear hidden objects.



**CAUTION:** for emergency reasons learn how to stop the tractor and cutter quickly.

On the Tornado rotary cutter always disengage the PTO, lock parking brake, stop engine and allow the blades to come to a complete stop before dismounting the tractor.

### 3.08 - Uneven Terrain



**WARNING:** be careful of roll-over when operating tractor and cutter over uneven ground.

In extremely uneven terrain rear wheel weights, front tractor weights, and/or tire ballast should be used to improve stability.

When mowing over uneven terrain, observe the type of terrain and develop a safe mowing pattern. Whenever traction or stability is doubtful, first test drive over the terrain with the PTO disengaged.

Operate the cutter up and down steep slopes, not across slopes, to prevent the tractor from tipping. Avoid sudden stops and starts and slow down before changing directions on a slope.

Pass diagonally through sharp dips and avoid sharp drops to prevent hanging up the tractor and cutter.

Slow down on sharp turns and slopes to prevent tipping or loss of control.



Avoid tipping the cutter while cutting. Watch for holes, roots or other hidden objects. Do not cut near the edge of a gully, ditch or stream bank.

### **3.09 - Removing Cutter from the Tractor**



**CAUTION:** disengage tractor PTO. Set parking brake. Stop engine and remove key from ignition. Disconnect cutter driveline from tractor PTO shaft. Collapse driveline and secure it in place with the storage hook on the machine three point hitch. Disconnect three point linkage and carefully drive tractor away from cutter.

**TABLE 1 - BOLT AND NUT TORQUE SPECIFICATIONS**

Diameter	Class 8.8		Class 10.9	
	N.m	lb.ft	N.m	lb.ft
M 8	25	18	35	26
M 10	50	37	70	52
M 12	90	66	125	92
M 14	140	103	200	148
M 16	215	155	305	225
M 18	295	217	420	309
M 20	420	302	590	438
M 27	910	655		
M 30	1.230	860		

When using locking nuts, increase torque value by 5%.

**TABLE 2 - TORNADO RMD - TECHNICAL FEATURES**

Series RMD for tractors up to 80 HP, PTO 540 rpm three point hitch cat. 1.										
Model	HP	Working width cm.	Overall width cm.	Weight kg	# Blades & Size mm.	Rotor rpm/min.	Blades tip speed m/sec.	Cutting height mm.	Wheels mm.	Driveline 1 3/8"
RMD-150	40-80	150	170x268	250	#2, 100x12	855	67	25/235	400x100	ASAE 4 <sup>th</sup> BT
RMD-180	40-80	180	200x297	335	#2, 100x12	855	80	25/235	400x100	ASAE 4 <sup>th</sup> BT

## 4 - MAINTENANCE



**DANGER: stop engine, lock parking brake and remove key before performing any service or maintenance.**

**Never rely on the tractor lift system. Install blocks or stands under the cutter deck to prevent it from falling. Always use personal protection devices, such as glasses or gloves when performing maintenance.**

**Keep fingers out of slots to prevent injury.**

### 4.01 - Maintenance Safety



1. Good maintenance is your responsibility.
2. Keep service area clean and dry. Be sure electrical outlets and tools are properly grounded. Use adequate light for the job at hand.
3. Make sure there is plenty of ventilation. Never operate the engine of the towing vehicle in a closed building. The exhaust fumes may cause asphyxiation.
4. Make no repair or adjustments with the tractor engine running. Before working on the machine, disengage the PTO, shut off the engine, set the brakes, and remove the ignition key.
5. Be certain all moving parts on attachment have come to a complete stop before attempting to perform maintenance.
6. Never work under equipment unless it is blocked securely.
7. Always use personal protection devices such as eye, hand and hearing protectors, when performing any service or maintenance.
8. Frequently check blades. They should be sharp, free of nicks and cracks and securely fastened.
9. Periodically tighten all bolts, nuts and screws and check that all cotter pins are properly installed to ensure unit is in a safe condition.
10. When completing a maintenance or service function, make sure all safety shields and devices are installed before placing unit in service.
11. Do not attempt to mount a tire unless you have the proper equipment and experience to do the job.
12. Never replace hex bolts with less than grade five bolts unless otherwise specified, i.e. shear bolts<sup>8</sup>.
13. When the machine is not hooked to the tractor, the driveline must be supported by the storage hook to the top link.

---

<sup>8</sup> Refer to table 1 - Torque Specifications, for head identification marking.

14. Where replacement parts are necessary for periodic maintenance and servicing, genuine replacement parts must be used to restore your equipment to original specifications. The company will not claim responsibility for use of unapproved parts and/or accessories and other damages as a result of their use.
15. Unauthorised modifications to the machine may impair the function and/or safety of the machine and reduce its life. If equipment has been altered in any way from original design, the manufacturer does not accept any liability for injury or warranty.

### 4.02 - Service

The accompanying illustrations show lubrication points. The chart gives the frequency of lubrication in hours, based on normal operating conditions. Severe or unusual conditions may require more frequent lubrication.

Use a good quality SAE multipurpose type grease for all locations shown. Be sure to clean fittings thoroughly before using grease gun.

Use 90 wt. or 140 wt. gear oil in gearbox.

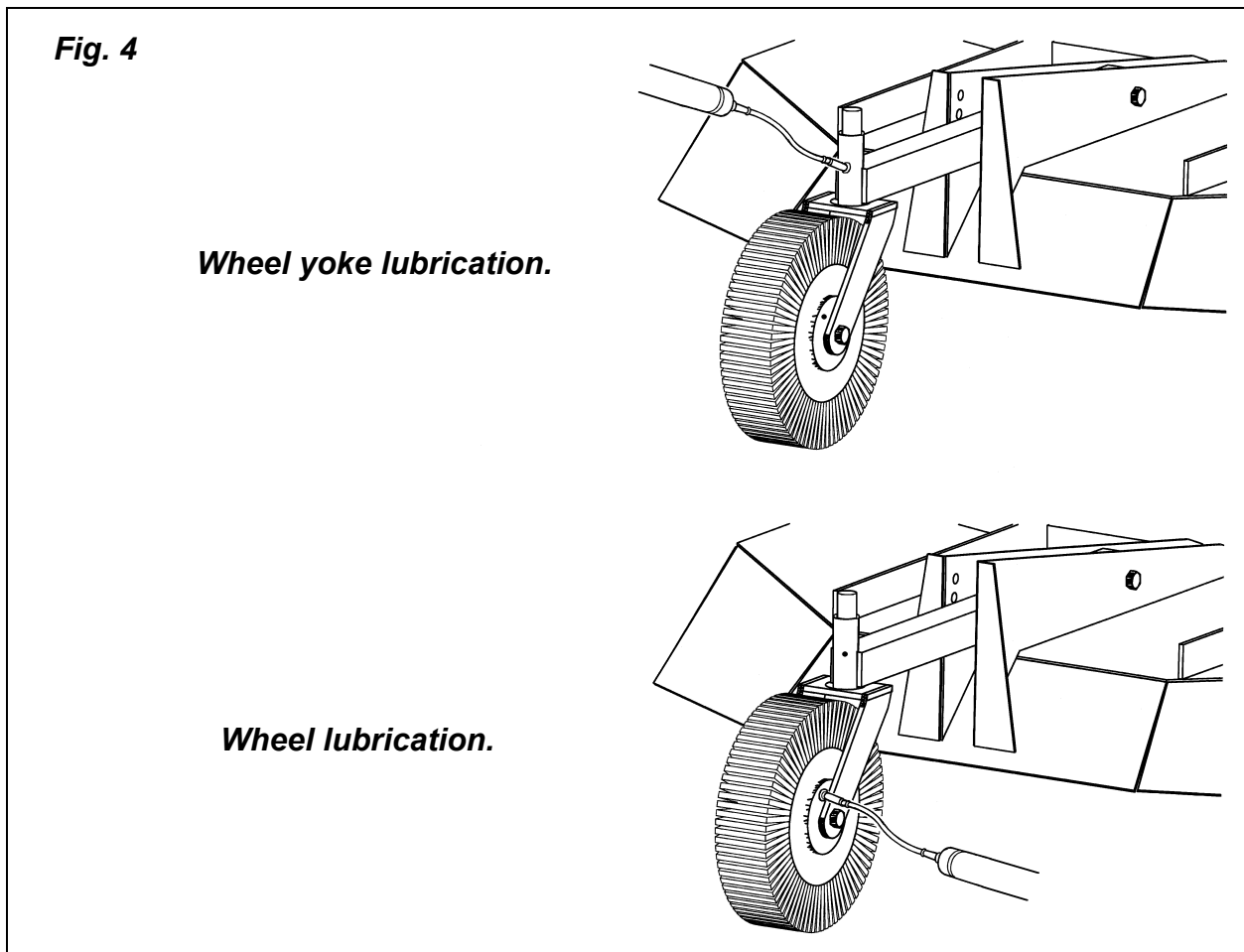

**Hourly:**

1. check the condition of cutter blades for nicks or dull edges.
2. Sharpen if necessary. Replace bent or damaged blades<sup>9</sup>.
3. Also check blades for damage after hitting an obstruction.
4. Clean foreign material from the deck.

**Every 8 hours:**

1. **lubricate driveline, lubricate caster wheel and tail wheel arm:** apply two or three shots of grease to the driveline cross and bearings and the telescoping shafts (**see fig. 4**); apply the same amount to the wheel arm grease fittings and the wheel grease fittings. See the driveline manufacturer operator's manual for further information on the driveline.
2. **Gearbox oil level:** check gearbox oil level, it should be between  $\frac{1}{2}$  and  $\frac{2}{3}$  full. If needed add either SAE 90 wt. or SAE 140 wt. gear oil.

**Every 25 hours: check hardware tightness;** cutter vibrations can loosen bolts<sup>10</sup>. Check tightness of the hardware periodically.

### 4.03 - Blade Maintenance



**WARNING:** avoid possible injury, wear proper eye and hand protection when servicing cutter blades.

Proper blade maintenance is important in order for the cutter to work properly, to always obtain a precision cut and to lower HP requirements thus keeping costs down. Blades must be kept sharp, at their original length and with corners intact. A blade must be replaced if, due to wear or damage, its original shape has been distorted. Blade sharpening is extremely important in order to get the best cutting results.

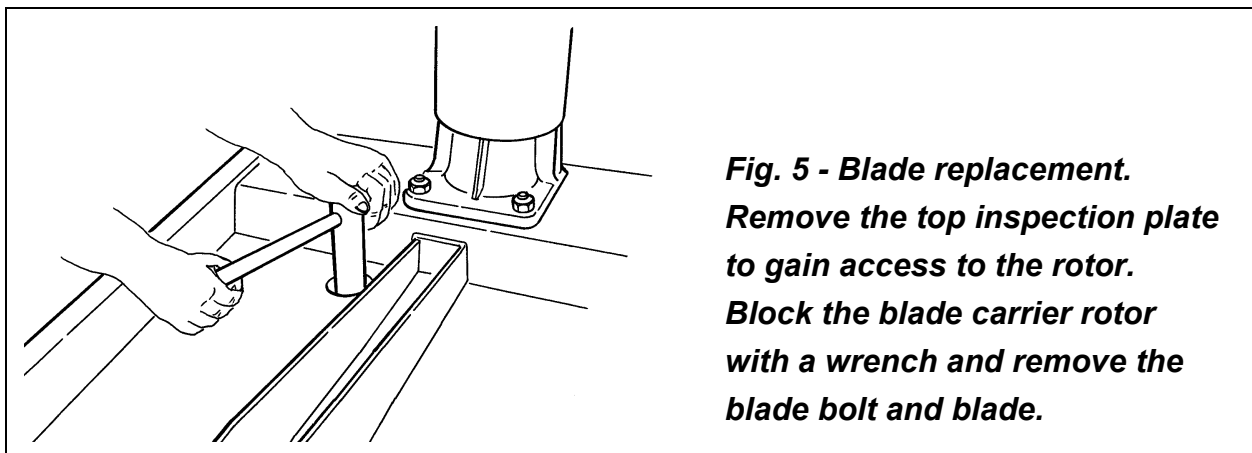

**Fig. 5 - Blade replacement.**  
**Remove the top inspection plate to gain access to the rotor.**  
**Block the blade carrier rotor with a wrench and remove the blade bolt and blade.**

<sup>9</sup> See Removing Blades in section 4.03 - Blade Maintenance, for details.

<sup>10</sup> Table 1 gives the correct torque values for various bolts and nuts.

### Removing or installing blades

Never rely on the tractor lift system. Install blocks or stands under the cutter deck to prevent it from falling.

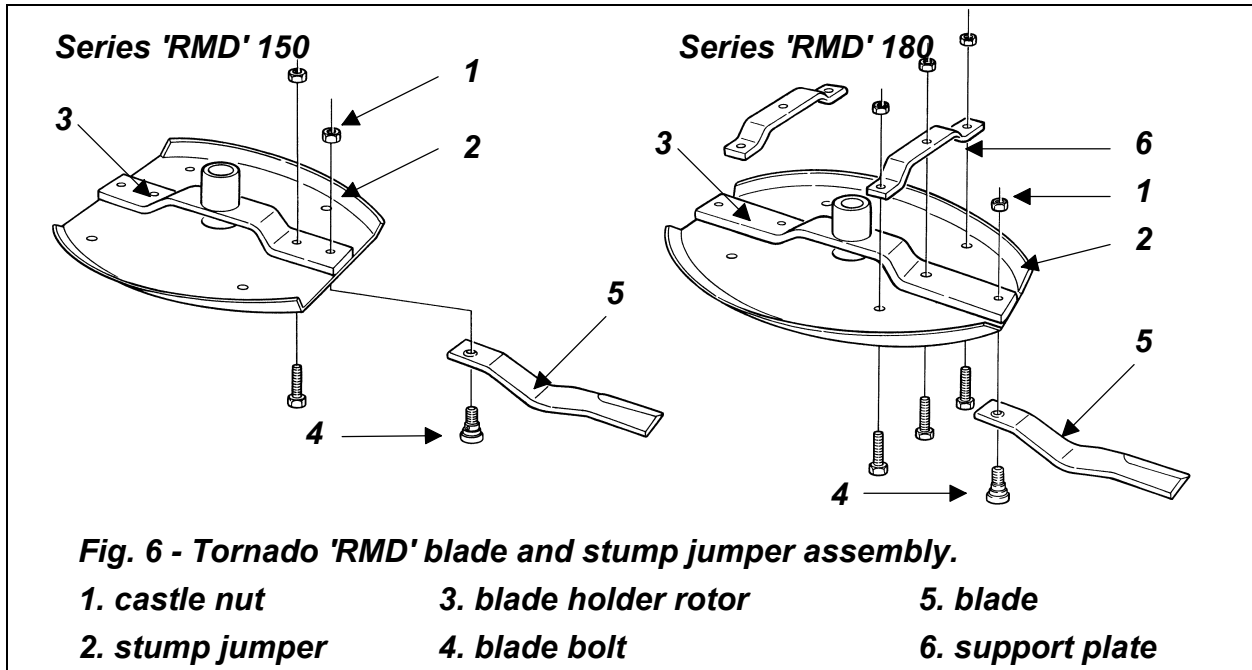

Proceed as follows (see fig. 6):

1. remove the top inspection plate to gain access to the rotor.
2. Block the blade carrier rotor with a wrench and remove the blade bolt nut (see fig. 5).
3. Remove the blade bolt and blade.
4. Check the bolt for wear. Replace if necessary.
5. Place the new blade making sure that the cutting edge is towards the direction of rotation. The blade turns in a clockwise direction when viewed from the bottom of the deck (see fig. 7).
6. Insert the blade bolt into the new blade and install into blade carrier rotor. Ensure the blade bolt pin is seated into the rotor properly.
7. Properly torque the nut to **360 N.m. (250 lb.ft.)**.

**IMPORTANT:** check blade bolt torque every 8 hours. Ensure the blades are able to free-swing. This is extremely important to prevent damage to the cutter.

**IMPORTANT:** when installing new blades, it is important that they be the same and the same weight to ensure balance. An unbalanced rotor blade carrier can damage the cutter.



**WARNING:** do not substitute blades or any bolt for the blade retaining bolt. Company blades and blade retaining bolts are specially made for this application.

Using non original parts can effect the quality of cut and may also cause damage to the machine.



**DANGER:** proper torque must be used when tightening the blade retaining bolt. If these safety precautions are not followed, the blade could come off during operation and be thrown tens of meters (hundreds of feet) from the cutter.

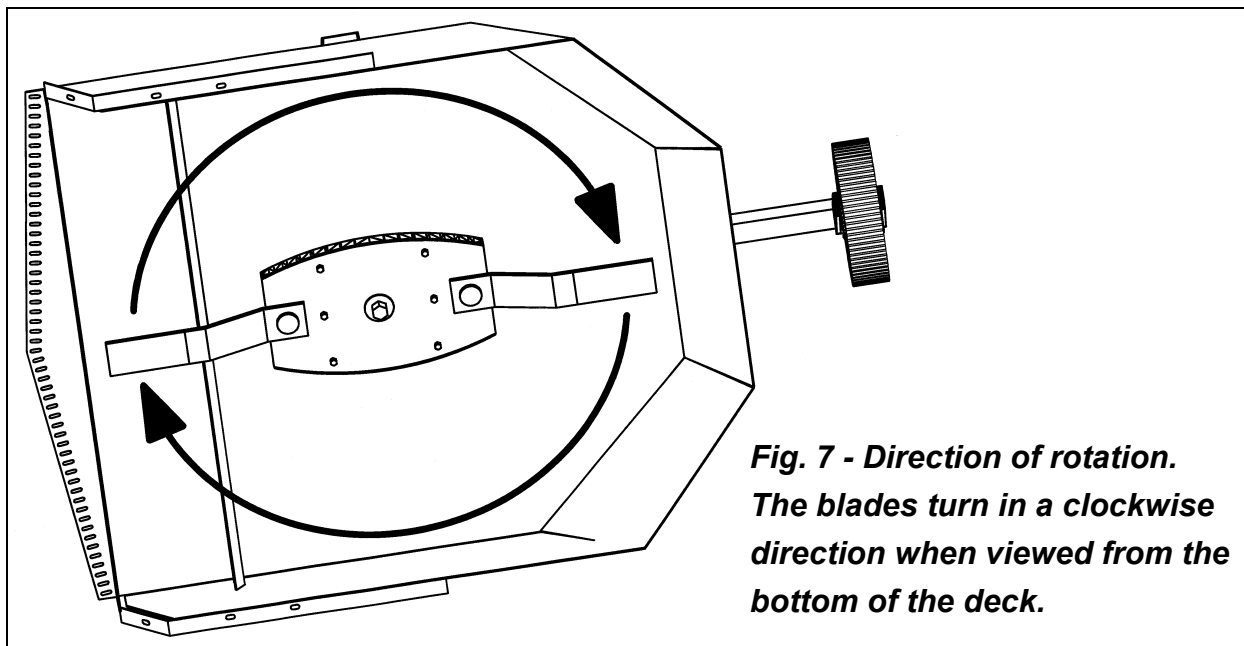

*Fig. 7 - Direction of rotation.  
The blades turn in a clockwise  
direction when viewed from the  
bottom of the deck.*

#### 4.04 - Rotor & Stump Jumper Assembly

To assemble the rotor to the stump jumper do the following:

- on **version 150:**
  1. position the rotor bar on the stump jumper so the holes line up.
  2. Attach the rotor to the stump jumper with the bolts provided (#2 - M16x2 of 50 mm.) and nuts. Torque to proper setting (**see fig. 6**).
- On **version 180:**
  1. position the rotor bar on the stump jumper so the holes line up.
  2. Attach the two support plates to the rotor with the bolts provided (#2 - M16x2 of 55 mm. & #4 - M16x2 of 30 mm.) and nuts. Torque to proper setting (**see fig. 6**).

## 4.05 - Driveline



**DANGER:** only use the original driveline supplied with this cutter and always with the safety shielding in place.

Carefully read and file away the driveline operator's manual supplied by the manufacturer. The following does not substitute the information found in the driveline manual.

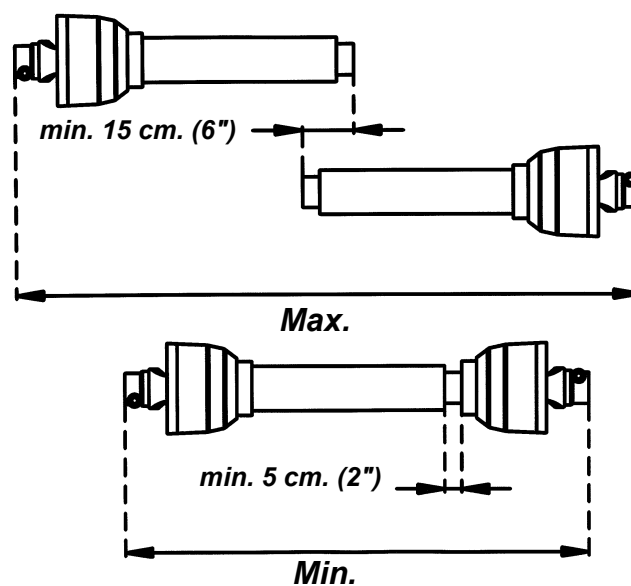

Fig. 8

In the collapsed position the driveline should be approximately 5 cm. (2") from bottoming out to prevent possible damage to the tractor or implement. When the PTO is in the maximum extended position, the ideal minimum overlap of the two halves should be approximately 15 cm. (6") (see fig. 8).

If determined that the driveline is too long. Follow these procedures to adjust the length:

1. separate the two driveline halves. Connect one half to the tractor PTO and the other half to the cutter.
2. Raise and lower the machine with the 3 point hitch to find the position where the driveline is shortest. Hold the half shafts side by side and mark the desired length on the outer female guard tube leaving a 5 cm. (2") gap between the end of the guard tube and bell guard.
3. Cut off both guard tubes the same amount as marked in step 2.
4. Shorten both drive tubes the same amount as guard tubes.
5. De-burr and clean filings from drive tubes and apply grease to outside of inner telescoping tube.



Reassemble the driveline halves and connect to tractor and cutter. Raise and lower cutter again to be sure driveline does not bottom out in shortest position and has a minimum overlap of 15 cm. (6") in the longest position.



**CAUTION:** always work with the driveline as straight as possible. This will prolong its life and that of its components. It is advised, not to work at an angle greater than 15 degrees.

When the cutter is not hooked to the tractor, the driveline must be supported by the storage hook attached to the top link.

### 4.06 - Safety Slip Clutch

When the cutter is supplied with a safety slip clutch, it is important to ensure it is working properly. The slip clutch delivered with your machine is set at a specific torque for normal working conditions.

If while working, the clutch slips frequently, the spring nuts need to be tightened  $\frac{1}{2}$  turn. Check the clutch after 200-250 m. (600-800 ft.), if necessary repeat the operation. If after tightening the nuts down and the clutch continues to slip, the discs will have to be replaced (see fig. 9).

Follow the instructions in reverse, if while working under normal conditions the clutch does not slip at all.

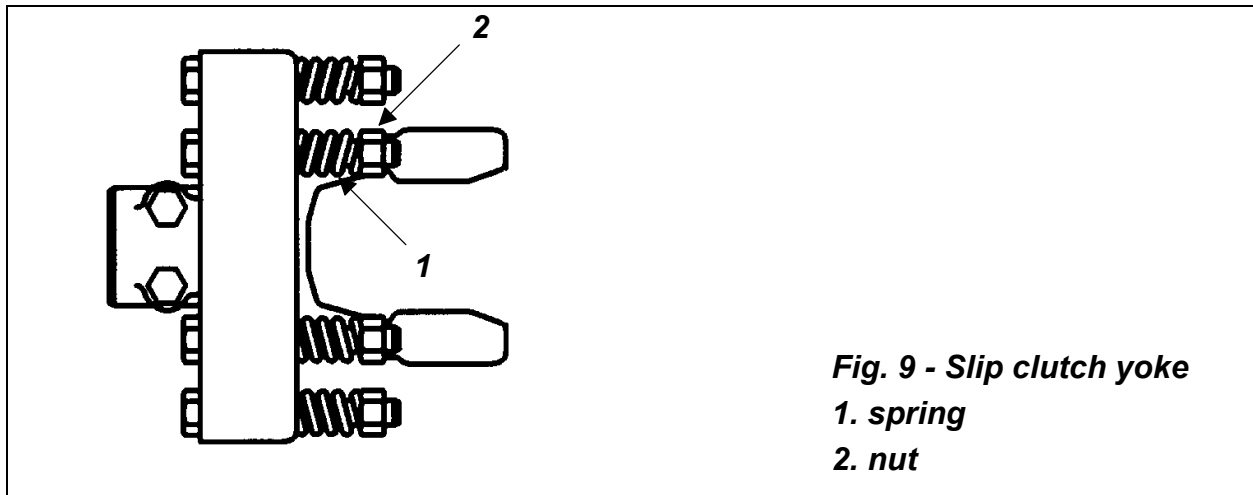

*Fig. 9 - Slip clutch yoke*

*1. spring*

*2. nut*

### 4.07 - Transport

Before raising the mower for transport, the tractor top link must be adjusted so when lifted, the rear of the machine is higher than the front (the mower's nose is tilted downward). To do this, shorten the tractor top link until the top hitch plate is locked forward and no longer able to pivot. This will keep the mower locked in position and

minimise the shaking and bouncing during transport which can damage the hitch or frame.

When raising the mower be sure the PTO driveline does not hit either the mower or the tractor. During transport the mower should not be lifted over 14"-16" from the ground.



**CAUTION: make sure PTO is disengaged and blades have stopped turning before raising cutter to full transport position.**

**Do not tow tractor and cutter behind other vehicles. Use a properly equipped trailer with heavy tie-downs for towing operations.**

To transport, do the following:

1. disengage PTO.
2. Shorten tractor top link until top hitch plate is locked.
3. Raise machine and lock rockshaft control lever.
4. Always select a safe ground speed that is appropriate for the terrain.
5. Beware of traffic on public roads. Install a SMV (Slow Moving Vehicle) sign when travelling on roads or streets.
6. Reduce ground speed when turning and take care that the cutter does not strike obstacles such as trees, fences or buildings.

## 5 - REPAIR PROCEDURES



**CAUTION:** all repair procedures must be done by authorised dealerships. It is not recommended that untrained individuals perform any repair work. The following operations are detailed for qualified personnel only.

### 5.01 - Gearbox

To remove the gearbox from the frame do the following:

1. never rely on the tractor lift system. Install blocks or stands under the cutter deck to prevent it from falling.
2. Remove the cotter pin from the castle nut which secures the blade carrier rotor to the pinion shaft.
3. Remove the castle nut and blade carrier rotor. Be sure to leave the washer on the pinion shaft.
4. Remove the bolts holding the gearbox to the frame and remove the gearbox.

If it is necessary to open the gearbox and replace internal parts, be sure to replace any oil seals or gaskets to ensure a tight fit when reassembling.

To replace the gearbox, reverse the above operations.

### 5.02 - Suggested Spare Parts

It is suggested that the following spare parts be kept on hand all times to prevent a minor problem from delaying work:

Description	Quantity
Blades	2
Blade bolts	2

### 5.03 - Storage

After seasonal use it is important to perform the following for prolonged storage:

1. wash the cutter carefully.
2. Inspect the machine, replace worn and damaged parts.
3. Tighten all hardware. Grease all areas indicated under maintenance.
4. Cover the cutter from the elements in order to have it in perfect condition for the start of the next season.

## 6 - TROUBLESHOOTING



**WARNING:** be sure tractor engine is off, parking brake is locked, and key is removed before making any adjustments.

PROBLEM	POSSIBLE CAUSE	SOLUTION
Irregular cut.	Cutter is not hooked up level. Blades are worn or bent.	Adjust three point hitch to level out the cutter. Replace blades.
Material not cut or laid over.	Wrappings around rotor. Cutter is not hooked up level. Tractor PTO speed too slow. Slip clutch slipping.	Remove wrappings. Adjust three point hitch to level out the cutter. Check tractor PTO speed. Check slip clutch.
Cutter is noisy.	Loose hardware. Gearbox oil level is low.	Tighten hardware. Add oil to gearbox.
High wear on blades.	Blades hitting ground.	Raise cutting height.
High wear on blade mounting holes (blade bolts).	Cutter is not working at the proper PTO rpm speed.	Check tractor PTO speed.
Vibrations.	Wrappings around blades. Improper tractor PTO speed. Unbalanced blades.	Remove wrappings. Check tractor PTO speed. Replace blades with identical pairs (the same weight).
Material bunching.	Material is too wet. Material is too high.	Allow material to dry. Raise cutting height. Reduce ground speed. Make two passes to cut.
Machine smells hot of begins to smoke.	Slip clutch slipping. Gearbox oil low.	Check slip clutch. Check oil level in gearbox.

## 7 - PRE-DELIVERY CHECKLIST

**To the dealer: inspect the machine thoroughly after assembly to assure it is functioning properly before delivering it to the customer. The following checklist is a reminder of points to cover. Check off each item as it is found satisfactory or after proper adjustment is made.**

- Gearbox oil level.
- Guards and shields properly fastened.
- Lubrication of grease fittings.
- All hardware properly tightened.
- All decals properly located and readable (**see fig. 2**).
- Blades properly installed and blade bolts & nuts tightened.
- Overall condition (touch up scratches, clean and polish).
- Test run, check for excessive vibration or overheating of bearings.
- Operator's Manual.

**Review the operator's manual with the customer. Explain the following:**

- Warranty.
- Safe operation and service.
- Correct machine installation and operation.
- Daily and periodic lubrication, maintenance and inspections.
- Troubleshooting.
- Operational procedures and storage.
- Parts and service.
- Remove and fill out the Delivery and Warranty Registration form.
- Give customer the operator's manual and encourage the customer to read the manual carefully.

**IMPORTANT: warranty is not valid unless Delivery and Warranty Registration Form in operator's manual is completed in detail and mailed to the Company.**

Model Number: \_\_\_\_\_ Serial Number: \_\_\_\_\_

Delivery Date: \_\_\_\_\_ Dealer's Signature: \_\_\_\_\_

## 8 - WARRANTY

The Company warrants its machine from defects in material and workmanship. The machines are warranted from the invoice date for the following periods.

1. **24 months** for private use.
2. **12 months** for commercial, contractual and public use.
3. **30 days** for loan or rental.

**This warranty is valid only if the Warranty Registration Form is properly completed and sent to the Company within 14 days of delivery along with copy of the invoice.**

**This warranty is valid only if the machine is paid for in full.**

The warranty coverage shall not be transferable from the first owner to any subsequent owner.

This document is the only warranty for this machine, any other promises, express or implied other than those set forth herein are not applicable.

The customer can not request any special provisions or changes to this warranty covering additional responsibilities or liability from the Company.

**The Company determines whether the warranty covers the substitution or the repairing of the machine or parts.**

The customer is responsible, in all cases, for expenses of lubricants, transportation, any custom duties and applicable taxes.

The substitution or the repair of parts under warranty do not extend the length of said warranty.

This limited warranty does not apply to and excludes drivelines and driveline related safety devices (shear pin yokes, shear pins, slip clutches, clutch discs), tires, belts, blades and other wear items.

At no time will the responsibility of the Company surpass the original purchase price of the machine. The purchaser agrees, not to have any rights to any compensation from the Company, including but not limited to, any eventual damages or accidents, loss of profit, loss of sales, injuries or damages of any kind or nature, or other accidents or losses which could result.

If during the period covered by this warranty, the machine fails to perform due to material or workmanship defects, the purchaser is to immediately make the Company aware of this defect. It is the Company's right to determine if the machine is to have parts replaced, repaired or the machine returned.

The Company will not accept any returned items without prior express written authorisation.

This warranty does not cover cost of labour for the replacement of parts.

Misuse or use of this machine other than ways outlined in the operator's manual or literature invalidates this warranty.

All obligations of the Company under this limited warranty shall be terminated if original parts of this machine have been modified or altered in any way, the machine has been repaired by unauthorised dealers, or when unauthorised spare parts have been used.

The Company reserves the right to modify or update machines without the obligation of modifying or updating previously sold machines.

**Venue: any judgements will be decided by the Verona Court.**

**EC Declaration of Conformity**

according to Directive 2006/42/EC

We

**ROTOMECC spa**  
**Via Molino di Sopra, 56**  
**37054 NOGARA (Verona) Italy**

declare under our sole responsibility, that the product:

**Rotary Cutter**  
**Tornado RMD**

to which this declaration relates corresponds to the relevant basic safety and health requirements of the Directive 2006/42/EC.

For the relevant implementation of the safety and health requirements mentioned in the Directives, the following standards were consulted: EN 745 and EN 4254-1.  
National and International requirements: ISO 11684

**Pio G. Figna**  
**Chief Executive Officer**

Nogara, \_\_\_\_\_

Determination of sound power levels under static conditions, in an essentially free field over a reflecting plane with a Landini model 5860 tractor.

Tractor: LpA 91 dB - LwA 105 dB

Machine connected to the tractor: LpA 91 dB - LwA 105 dB



# WARRANTY REGISTRATION

**ROTOMEK spa**

**Via Molino di Sopra, 56**

**37054 Nogara (Verona) - Italy**

**Tel.: +39-0442-510400 - Fax: +39-0442-510038**

Dealer _____ Acct. # _____	Retail Customer _____
Street _____ Country _____	Street _____
Town _____ State _____ Zip _____	Town _____ State _____ Zip _____
Date of delivery _____ Invoice # _____	Phone _____
Model # _____ Serial # _____	Date _____
<p>Pre-Delivery Check List:</p> <ul style="list-style-type: none"> <li><input type="checkbox"/> Oil in gearbox.</li> <li><input type="checkbox"/> Greased fittings.</li> <li><input type="checkbox"/> Safety guards in place.</li> <li><input type="checkbox"/> All hardware tight.</li> <li><input type="checkbox"/> Blades bolts torqued correctly.</li> <li><input type="checkbox"/> Attached unit to tractor. Yes/No.</li> <li><input type="checkbox"/> Field adjusted. Yes/No.</li> <li><input type="checkbox"/> Test run. Dry/Infield.</li> <li><input type="checkbox"/> Instruction Sticker.</li> <li><input type="checkbox"/> Operator's manual.</li> </ul> <p>The machine described above, has been prepared for delivery according to the Pre-Delivery Check List and the Customer has been instructed in its care and operation and the condition of warranty.</p> <p>Inspected by: _____</p> <p>Date: _____</p> <p>Dealer's Signature: _____</p>	<p>Tractor make: _____</p> <p>Model: _____; HP _____</p> <p>Type of operation: wheat and corn stalks, sunflowers, artichokes, potatoes, though mowing assignments, bushes, airport maintenance, road maintenance, other: _____</p> <p>Approximate number of acres the machine will be used on annually: _____</p> <p>I hereby acknowledge that:            I have received and accepted delivery of the machine described.            The equipment was checked thoroughly for loose or missing parts and has been adjusted in accordance with the pre-delivery checklist.            I have read and understand the nature and extent of the warranty and understand clearly that there were and are no other representations of warranties either express or implied, made by anyone. I have been advised on proper operation, maintenance and lubrication procedure of this equipment.            I have been instructed on and do understand the application, limitation and capacities this equipment was designed and recommended for, all as described in the operator's manual and literature published by the Company.</p> <p>Date: _____</p> <p>Customer's Signature: _____</p>

**This registration along with a copy of the invoice must be send to Rotomek spa within 14 days of date of purchase.**

**Sender:**

*Fold here*

---

*Place stamp  
here*

**ROTOMECC spa**  
Via Molino di Sopra, 56  
37054 Nogara (VR)  
ITALY

*Cut along this line*



## **Use only original spare parts**

*All rights reserved. It is unlawful to copy, reprint or use any of the information or details in this manual without the expressed written permission of ROTOMECC spa, Nogara, (Verona) Italy. Technical information provided in this manual is approximate, the Company reserves the right to modify or improve the models shown for technical or commercial purposes. Pictures in this manual do not necessarily show the machine as delivered.*

---

**ROTOMECC spa**

Via Molino di Sopra, 56

37054 Nogara (VR) - ITALY

Tel: +39.0442.510400 Fax: +39.0442.510038

[www.rotomecc.com](http://www.rotomecc.com)

