

ROTOMECH

Operator's Manual

CYCLONE

Three Spindle Grooming Mower Series C70

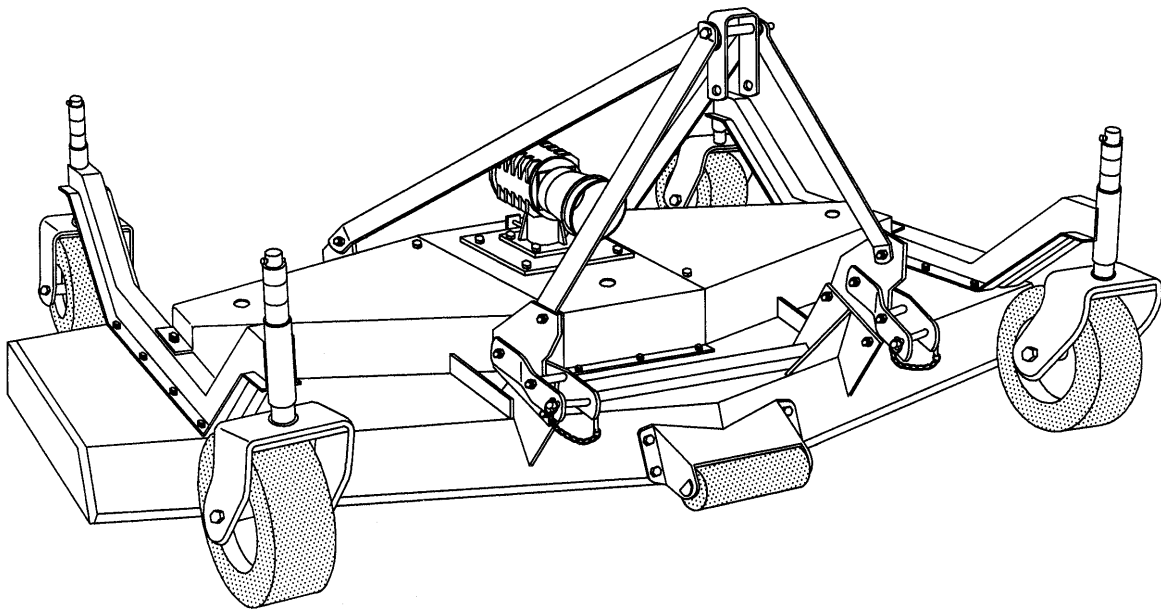

The operator's manual is a technical service guide and must always accompany the machine.

SAFETY

Take note! This safety alert symbol found throughout this manual is used to call your attention to instructions involving your personal safety and the safety of others. Failure to follow these instructions can result in injury or death.



*This symbol means:
ATTENTION!
BECOME ALERT!
YOUR SAFETY IS INVOLVED!*

Signal Words

Note the use of the signal words DANGER, WARNING and CAUTION with the safety messages. The appropriate signal words for each has been selected using the following guidelines:



DANGER: indicates an imminently hazardous situation that, if not avoided, will result in death or serious injury.



WARNING: indicates a potentially hazardous situation that, if not avoided, could result in death or serious injury, and includes hazards that are exposed when guards are removed. It may also be used to alert against unsafe practices.



CAUTION: indicates a potentially hazardous situation that, if not avoided, may result in minor or moderate injury.

ROTOMECH

Operator's Manual

CYCLONE

Three Spindle Grooming Mower Series C70

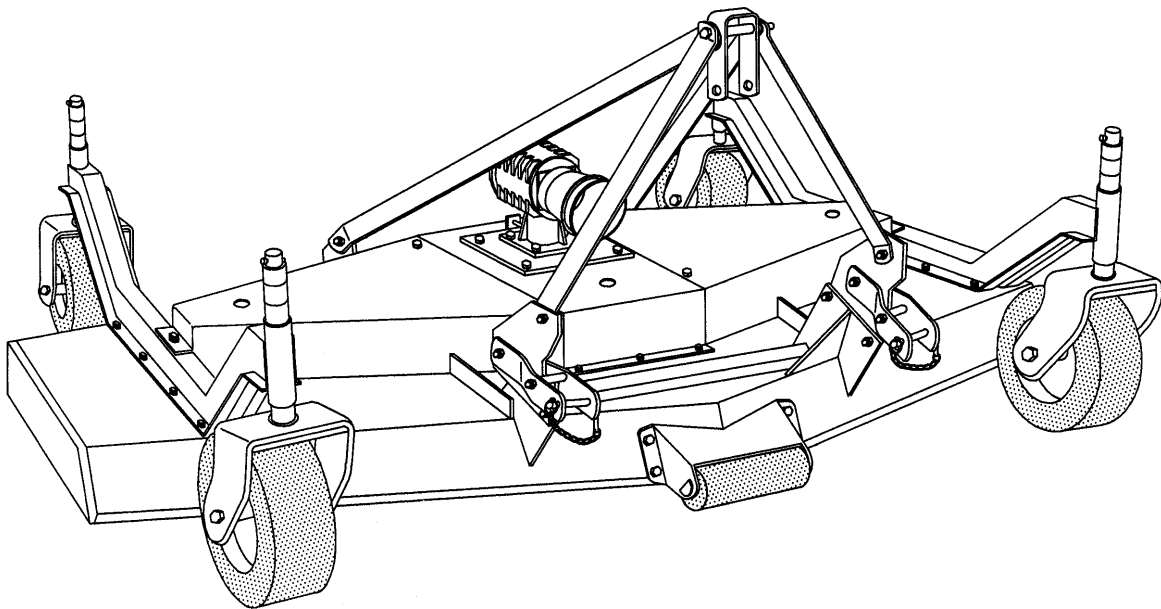

The operator's manual is a technical service guide and must always accompany the machine.

INDEX

1 - GENERAL INFORMATION	5
1.01 - General	5
1.02 - Model and Serial Number ID	5
2 - SAFETY PRECAUTIONS	7
2.01 - Preparation	7
2.02 - Starting and Stopping	8
2.03 - Messages and Signs	8
3 - OPERATION	10
3.01 - Operational Safety	10
3.02 - Setup	12
3.03 - Cutting Height Adjustment	13
3.04 - Pre-Operational Check	14
3.05 - Attaching to the Tractor	15
3.06 - Start Up	16
3.07 - Working Speed	17
3.08 - Operating Techniques	17
3.09 - Uneven Terrain	18
3.10 - Removing Mower from the Tractor	19
4 - MAINTENANCE	21
4.01 - Maintenance Safety	21
4.02 - Service	22
4.03 - Blade Maintenance	24
4.04 - Belt Tension	26
4.05 - Belt Replacement	27
4.06 - Driveline	28
4.07 - Transport	29
5 - REPAIR PROCEDURES	30
5.01 - Gearbox	30
5.02 - Blade Spindle	30
5.03 - Suggested Spare Parts	32
5.04 - Storage	32
6 - TROUBLESHOOTING	33
7 - PRE-DELIVERY CHECKLIST	34
8 - WARRANTY	35

1 - GENERAL INFORMATION

Thank you and congratulations for having chosen our implement.
Your new grooming mower is a technologically advanced machine constructed of high quality sturdy components that will fulfil your working expectations.
Read this manual carefully. It will instruct you on how to operate and service your mower safely and correctly. Failure to do so could result in personal injury and or equipment damage.

1.01 - General





CAUTION: all hardware is metric. Only metric tools should be used. Other tools that do not fit properly can slip and cause injury.



CAUTION: right hand and left hand sides of the implement are determined by facing in the direction the implement will travel when going forward (see fig. 2).

1.02 - Model and Serial Number ID

Attached to the frame is an ID plate showing the model and serial number (see below). Record your implement model and serial number in the space provided below, a facsimile of the ID Plate on the machine. Your dealer needs this information to give you prompt, efficient service when you order parts.

 ROTOMECC S.p.A. 37054 NOGARA (VERONA) ITALY PH.: 39.(0).442.510400 r.a.		
MOD.		N.
KW.	KG.	YEAR

Carefully read the warranty section¹, detailing coverage and limitations of this warranty.

Warranty is provided for customers who operate and maintain their equipment as described in this manual. Warranty registration is accomplished by the dealer by completing and forwarding the **Warranty Registration Form** to the Company, along with a copy of the dealer's invoice. It is in your best interest to insure that this has been done.

Warranty does not cover the following:

1. cleaning, transporting, mailing and service call charges.
2. Normal wear items such as belts, blades, bearings, drive lines, shear pins, slip clutches etc.
3. Depreciation or damage caused by normal wear, accidents, improper maintenance, improper protection or improper use.
4. The use of non original spare parts and accessories.

Your Authorised Company Dealer has genuine parts in stock. Only these approved replacement parts should be used.

This limited warranty covers defective material and workmanship. The cost of normal maintenance or repairs for accidents or improper use and related labour will be borne by the owner.

¹ See chapter 8 - Warranty.

2 - SAFETY PRECAUTIONS

Safety is the primary concern in the design and manufacture of our products. Unfortunately our efforts to provide safe equipment can be wiped out by a single careless act of an operator.

In addition to the design and configuration of equipment, hazard control and accident prevention are dependent upon the awareness, concern, prudence and proper training of personnel involved in the operation, transport, maintenance and storage of equipment.

It is the operator's responsibility to read and understand all safety and operating instructions in the manual and to follow these.

Allow only properly trained personnel to operate the mower. Working with unfamiliar equipment can lead to careless injuries. Read this manual, and the manual for your tractor, before assembly or operating, to acquaint yourself with the machines. It is the mower owner's responsibility, if this machine is used by any person other than yourself, is loaned or rented, to make certain that the operator, prior to operating, reads and understands the operator's manuals and is instructed in safe and proper use.

2.01 - Preparation



1. Before operating equipment read and understand the operator's manual and the safety signs (**see fig. 2**).
2. Thoroughly inspect the implement before initial operation to assure that all packaging materials, i.e. wires, bands, and tape have been removed.
3. Personal protection equipment including hard hat, safety glasses, safety shoes, and gloves are recommended during assembly, installation, operation, adjustment, maintaining and/or repairing the implement.
4. Operate the mower only with a tractor equipped with an approved Roll-Over-Protective-System (ROPS). Always wear your seat belt. Serious injury or even death could result from falling off the tractor.
5. Clear area to be cut of stones, branches or other debris that might be thrown, causing injury or damage.
6. Operate only in daylight or good artificial light.
7. Ensure mower is properly mounted, adjusted and in good operating condition.
8. Ensure that all safety shielding and safety signs are properly installed and in good condition.

2.02 - Starting and Stopping



1. Be sure that no one is near the machine prior to engaging or while the machine is working.
2. Be sure the tractor is in "Neutral" before starting engine.
3. Mower operating power is supplied from tractor PTO. Refer to your tractor manual for PTO engagement and disengagement instructions. Always operate PTO at 540 rpm. Know how to stop the tractor and mower quickly in case of an emergency.
4. When engaging PTO, the engine rpm should always be low. Once engaged and ready to start cutting, raise PTO speed to 540 rpm and maintain throughout cutting operation.
5. Check the tractor master shield over the PTO stub shaft. Make sure it is in good condition and fastened securely to the tractor. Purchase a new shield if old shield is damaged or missing.
6. After striking an obstacle, disengage the PTO, shut the tractor down and thoroughly inspect for damage before restarting.
7. Never engage the PTO until the mower is in the down position and resting on the ground. Never raise the mower until all blades have come to a complete stop.

2.03 - Messages and Signs



1. Read and adhere to all safety and operating decals on this machine (**see fig. 2**).
2. Before dismounting tractor: allow moving parts to stop, stop engine, set brake and remove the key of unattended equipment.
3. Keep away from rotating blades and driveline.
4. Keep guards and shields in place and in good condition.
5. Do not mow with bystanders in area.
6. Allow no riders on tractor or mower.
7. Allow moving parts to stop before repair.
8. Securely support mower before working underneath.

Additional warning and operating decals are available at no extra charge. Please specify model and serial number when ordering.

Fig. 2 - Safety decals; replace immediately if damaged.

- 1. Read the manual carefully.**
- 2. Before maintenance operations, disengage PTO and shut tractor down.**
- 3. 540 rpm PTO only.**
- 4. Keep away from rotating driveline.**
- 5. Keep away, objects can be thrown.**
- 6. Never allow passengers.**
- 7. Keep away from rotating blades.**
- 8. Keep away from rotating belts.**
- 9. Keep away from raised mower.**

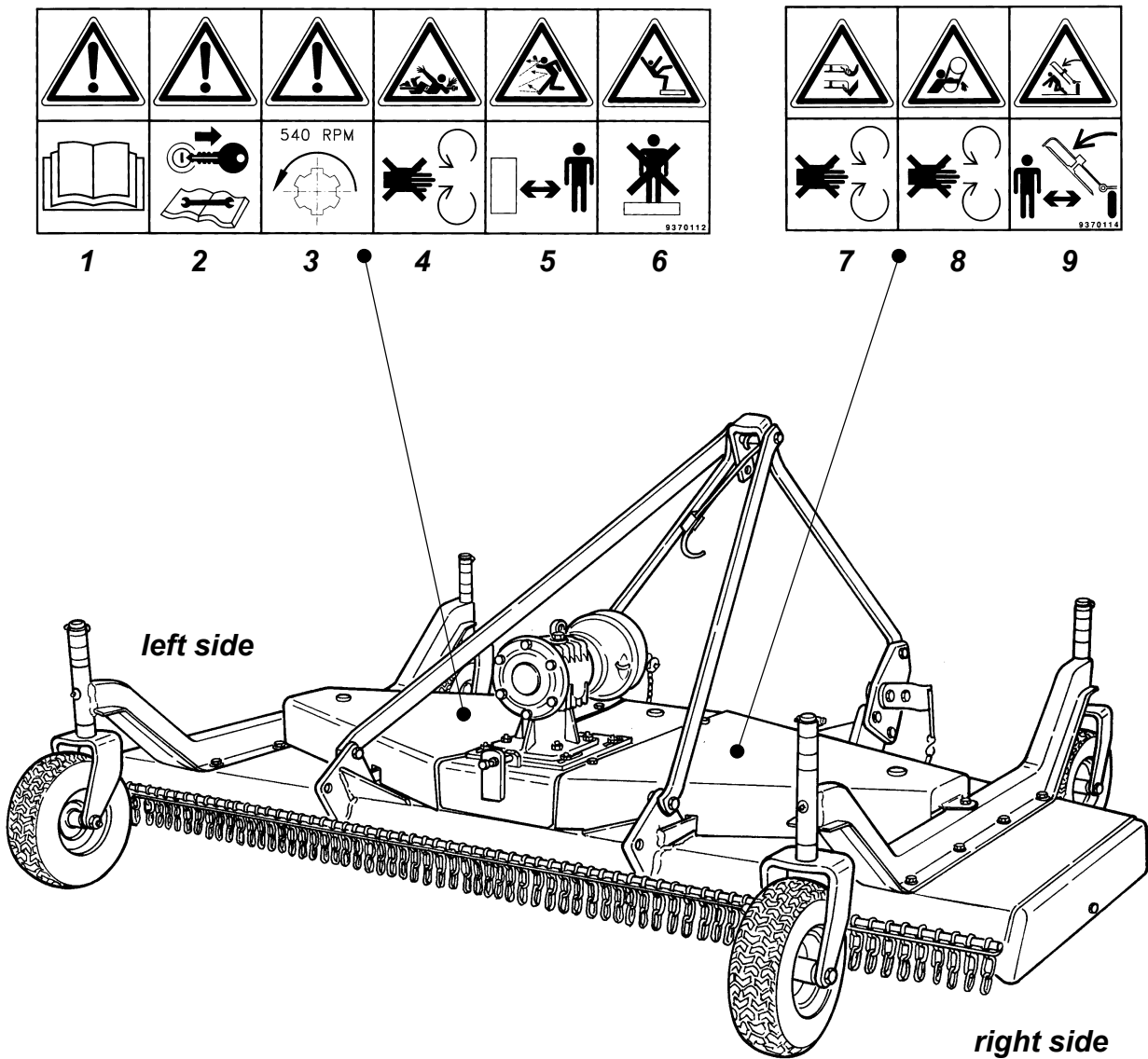

3 - OPERATION

You have purchased a three spindle mower designed especially for the mowing of grassy areas where a highly professional cut is required without wasting time.

This mower is perfect for the maintenance of parks, private lawns, industrial parks, airports, hospital grounds, schools, highways, golf courses, sport complexes, etc. The C70 series, for tractors up to 70 HP, come in working widths of 230 and 280 cm. (90" & 110"). The mower can be either tractor front or rear mounted. On your mower, the tractor PTO transmits its power through a driveline to a speed multiplier gearbox. A pulley is attached to the pinion gear shaft of the gearbox which, via high resistance belts, transmits power to pulleys coupled to the three individual spindle shafts. Blades are secured to these shafts which turn at a high blade tip speed to cut the grass.

Our C70 grooming mower comes equipped with 4 swivel wheels. Aside from regulating the cutting height, the wheels are set in such a way as to allow the mower to follow the contour of the terrain and give a precise level cut even in undulating conditions.

3.01 - Operational Safety



CAUTION: our mowers are designed considering safety as the most important target and are the safest available in today's market. Unfortunately, human carelessness can override the safety features built into our machines. Injury prevention and work safety, aside from the features on our mowers, is very much due to the responsible use of the equipment. It must always be operated prudently following with great care, the safety instructions laid out in this manual.



1. The use of this equipment is subject to certain hazards which cannot be prevented by mechanical means or product design. All operators of this equipment must read and understand this entire manual, paying particular attention to safety and operating instructions, prior to using.
2. Do not operate the tractor and mower when you are tired, sick or when using medication.
3. Keep all helpers and bystanders at least several meters from a rotary mower. Only properly trained people should operate this machine.
4. When this machine is operated in populated areas where thrown objects could injure persons or property, standard equipment safety chain shielding (which is designed to reduce the possibility of thrown objects) must be installed.

5. The majority of accidents involve entanglements on the driveline, injury of bystanders by objects thrown by the rotating blades, and operators being knocked off the tractor by low hanging limbs and then being run over by the mower. Accidents are most likely to occur with machines that are loaned or rented to someone who has not read the operator's manual and is not familiar with a rotary mower.
6. Always stop the tractor, set brake, shut off the tractor engine, remove the ignition key, lower implement to the ground and allow mower blades to come to a complete stop before dismounting tractor. Never leave equipment unattended with the tractor running.
7. Never place hands or feet under mower with tractor engine running or before you are sure all motion has stopped. Stay clear of all moving parts.
8. Do not allow riders on the mower or tractor at any time. There is no safe place for riders.
9. Do not operate unless all personnel, livestock and pets are several meters away to prevent injury by thrown objects.
10. Before backing up, disengage the mower and look behind carefully.
11. Install and secure all guards and shields before starting or operating.
12. Keep hands, feet, hair and clothing away from moving parts.
13. This rotary mower is designed for use only on tractors with 540 rpm power take off².
14. Never operate tractor and mower under trees with low hanging limbs. Operators can be knocked off the tractor and then run over by the rotating blades.
15. The rotating parts of this machine have been designed and tested for rugged use. However, they could fail upon impact with heavy, solid objects such as steel guard rails and concrete abutments. Such impact could cause the broken objects to be thrown outward at very high velocities. To reduce the possibility of property damage, serious injury, or even death, never allow the cutting blades to contact such obstacles.
16. Frequently check mower blades. They should be sharp, free of nicks and cracks and securely fastened.
17. Stop mower immediately upon striking an obstruction. Turn engine off, remove key, inspect and repair any damage before resuming operation.
18. Stay alert for holes, rocks and roots in the terrain and other hidden hazards. Keep away from drop-offs.
19. Use extreme care and maintain minimum ground speed when transporting on hillside, over rough ground and when operating close to ditches or fences. Be careful when turning sharp corners.
20. Reduce speed on slopes and sharp turns to minimise tipping or loss of control. Be careful when changing directions on slopes. Do not start or stop suddenly on slopes. Avoid operation on steep slopes.
21. When using a unit, a minimum 20% of tractor and equipment weight must be on tractor front wheels. Without this weight, tractor could tip over, causing personal injury or death. The weight may be attained with a front end loader, front wheel weights, ballast in tires or front tractor weights. When attaining a minimum 20%

² A special version with PTO at 1000 rpm is available upon request.

- of tractor and equipment weight on the front wheels, you must not exceed the ROPS weight certification. Weigh the tractor and equipment. Do not guess or estimate!
22. Inspect the entire machine periodically³. Look for loose fasteners, worn or broken parts, and leaky or loose fittings.
 23. Use only the driveline supplied with the mower. Do not use it if it is missing any shield or safety protection.
 24. Pass diagonally through sharp dips and avoid sharp drops to prevent "hanging up" tractor and mower.
 25. Avoid sudden starts and stops while travelling up or downhill.
 26. Always cut down slopes; never across the face. Avoid operation on steep slopes. Slow down on sharp turns and slopes to prevent tipping and or loss of control.

3.02 - Setup

Notice to dealer: pre-delivery setup and service including lubrication is the responsibility of the authorised dealer. It is up to him to assure that the machine is in perfect condition and ready to be used. It is his responsibility to ensure that the customer is aware of all safety aspects and operational procedures for the mower. He must also fill out the Pre-delivery Checklist⁴ prior to delivering the mower.

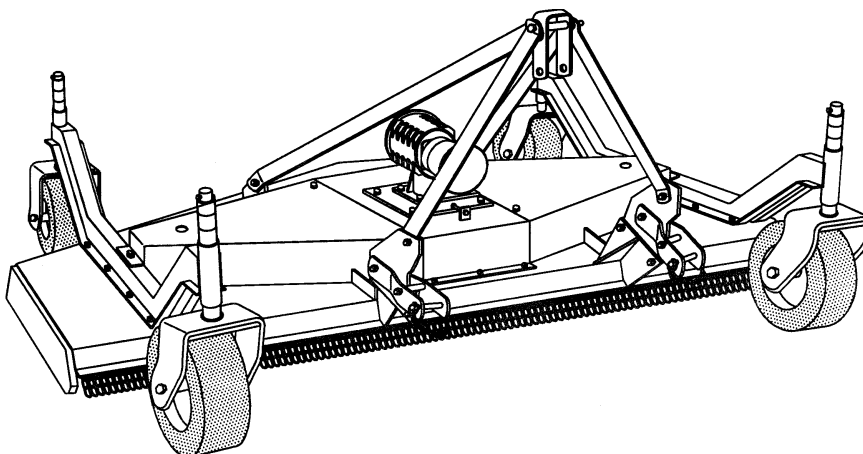

Fig. 3 - 'C70' mower front mounted.

All our grooming mowers may be either tractor front or rear mounted. To change our mowers from front mount to rear, or vice versa, it can easily be done at our authorised dealerships. This is accomplished by simply turning the three point hitch and the gearbox 180 degrees (**see fig. 3 & 4**).

³ See chapter 4 - Maintenance.

⁴ See chapter 7 - Pre-delivery Checklist.

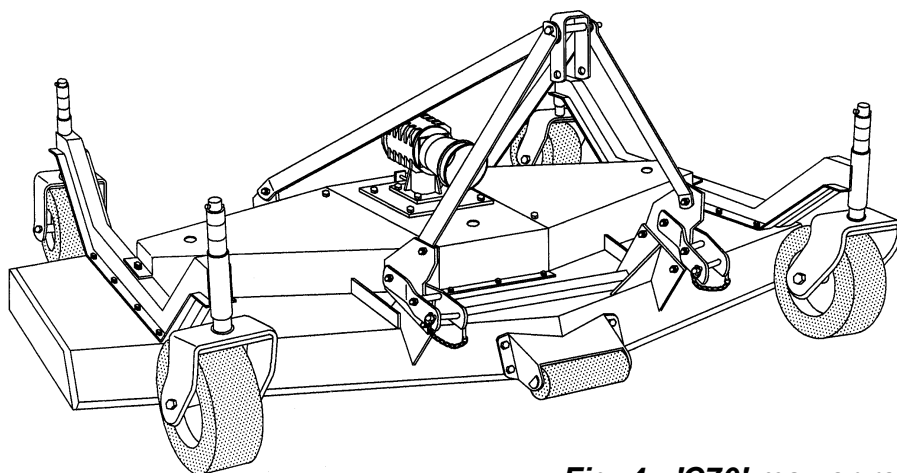

Fig. 4 - 'C70' mower rear mounted.



CAUTION: stand clear of bands when cutting as they could be under sufficient tension to cause them to fly loose. Take care in removing bands and wire, they often have extremely sharp edges and cut very easy.

3.03 - Cutting Height Adjustment



WARNING: keep hands and feet away from moving blades.

Be sure tractor engine is off, parking brake is locked, and key is removed before making any adjustments.

Never rely on the tractor lift system. Install blocks or stands under the mower deck to prevent it from falling.

The cutting height is the distance from the blades to the ground. The cutting height is adjusted by **moving the spacers on the wheel yokes**. Placing spacers between the wheel arm and the wheel yoke raises the cutting height by the size of the spacer. Removing the spacers, lowers it by the same height (**see fig. 5**).

Be sure all wheel arms are adjusted equally. This is the only way to ensure a completely uniform cut.

Fig. 5
The cutting height is adjusted by moving the height adjustment spacers on the wheel yokes above or below the wheel arm.

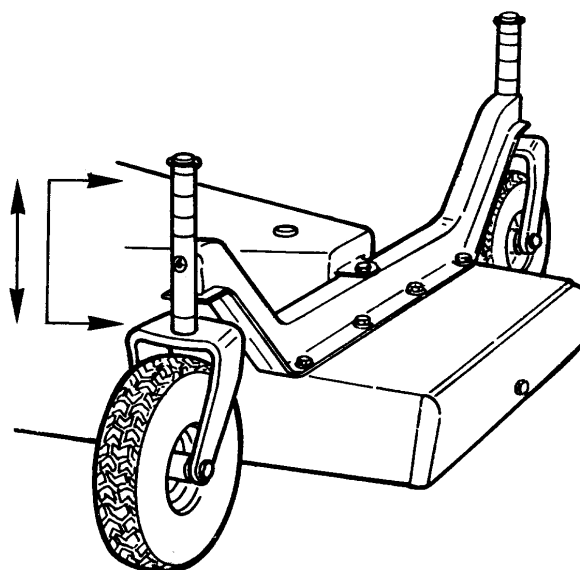

IMPORTANT: very low cutting heights should be avoided. Damaging shock loads occur when the blades strike the ground repeatedly. This can cause damage to the mower.

Cutting lower than 5 cm. (2") under most circumstances should be avoided.

The cutting height is adjustable from 35 to 135 mm. (1.3" to 5.3").

A front anti-scalp roller is standard equipment. This is particularly helpful when cutting over uneven terrain.

3.04 - Pre-Operational Check

Check each of the following carefully prior to engaging the equipment:

1. the spindle bearings have been greased.
2. The belts for proper tension.
3. The oil in the gearbox.
4. The driveline cross & bearings have been greased.
5. No wrappings or foreign objects are around the blades, belts or driveline.
6. The blades are properly installed and the blade bolts properly torqued⁵.
7. All hardware is tight.
8. The tractor, to ensure correct direction of PTO and rpm speed.
9. All safety shields and guards are in place and tightly attached.
10. No people or animals are in the work area.

⁵ See table 1, page 20.

11. When working, make sure the tractor hitch is in the "float" position, in order to allow the mower to follow the contour of the ground.



DANGER: stay clear of rotating driveline. Entanglement in rotating driveline can cause serious injury. Disengage PTO, engage parking brake or place transmission in "Park", shut off the tractor and remove the key before working around hitch, attaching or detaching driveline, making adjustments, servicing or cleaning the machine.

3.05 - Attaching to the Tractor

Only use this model implement with tractors in the correct power range⁶. **Never use this mower with tractors over 70 HP.**



CAUTION: check the tractor PTO rpm to ensure it is set at 540 and turns clockwise.



CAUTION: always ensure that the tractor tire pressure is correct according to the tractor operator's manual.



DANGER: failure to ensure a secure coupling of the implement to the tractor can cause injury and damage to the implement or tractor.

To attach the mower to the tractor do the following:

1. back the tractor up to the mower in order to slip the tractor hitch arms over the hitch pins welded to the mower hitch arms. **Turn off the tractor engine.** Secure them in place with the lynch pins.
2. Adjust the tractor sway blocks or chains to remove all side movement.
3. Attach the top link, securing it in place with the top hitch pin. Adjust tractor top link to allow the mower to follow the ground contour and yet remain as level as possible when raised to the transport position.
4. Install the shielded driveline to the tractor by first lining up the splines and depressing the snap pin. Push the yoke onto the PTO shaft as far as it will go. Release the pin and pull back slowly until the pin clicks in place. Repeat this operation on the implement end.

⁶ See table 2, page 20.

5. Attach the driveline chains to the tractor and to the mower to keep the driveline protection from turning. The chains should not be too tight.

3.06 - Start Up



DANGER: the mower must always be lowered to the ground before starting tractor engine or engaging PTO lever.

Lower mower to the ground with the tractor rockshaft control lever. With the engine idling, slowly engage the PTO drive. Move the throttle lever until the PTO speed indicated on the mower is obtained. The mower is set for a PTO speed of 540 rpm⁷. Shift the transmission to a slow speed gear and start forward, increase the ground speed by shifting upward until the desired speed is obtained. Do not mow in reverse unless absolutely necessary and only after careful observation of the area behind the mower.



CAUTION: do not operate this mower at a PTO speed or direction of rotation other than that shown on the mower. Serious damage can occur to the machine and/or the operator.

Before starting to mow, never forget that the **operator is responsible** for the following:

1. safe and correct driving of the tractor and mower.
2. To learn precise, safe operating procedures for both the tractor and the mower.
3. To ensure all maintenance and lubrication has been performed on the mower.
4. To have read and understood all safety aspects for the mower in the operator's manual.
5. To have read and understood all safety decals on the mower.
6. Checking the condition of the blades. Worn or damaged blades should be changed before starting⁸.
7. Checking to ensure that the cutting edge is the leading edge of the blade⁹.
8. Checking that there is no wire, weed, grass or other material wrapped around blades.
9. Checking to see if front weights need to be added to the tractor in order to maintain balance.
10. Checking the tractor tires for the proper pressure in accordance with the tractor operator's manual.

⁷ A special version with 1000 rpm PTO is available upon request.

⁸ See chapter 4.03 - Blade Maintenance.

⁹ See chapter 4.03 - Blade Maintenance.

11. **Checking that the PTO shield, belt shields and all other shielding are on the machine and securely in place.**
12. Making sure the proper attire is worn. Avoiding loose fitting clothing which can become entangled. Wearing sturdy, tough-soled work shoes and protective equipment for eyes, hands, ears and head. Never operate tractor or implements in bare feet, sandals or sneakers.
13. Checking area for stones, branches and other debris that might be thrown.
14. Ensuring proper lighting is available, sunlight or good artificial lighting.

3.07 - Working Speed

The mowing speed depends on ground conditions, tractor HP, mowing height and grass thickness. Only a test run will enable you to gauge the optimal working speed for your conditions.

Under most conditions a 4 to 13 km/h (3 to 8 mph) ground speed is best. As a rule of thumb, and if the conditions permit, grass dispersion is increased by higher ground speeds.

In order to obtain the best cut possible, always keep the tractor rpm up to the speed indicated on the mower. When increasing or decreasing mowing ground speed, always use gear selection, not engine speed. This will maintain the constant maximum blade speed necessary for a clean cut.

3.08 - Operating Techniques

All of the following factors are important in selecting the proper forward speed:

1. height of grass.
2. Type of grass.
3. Density of grass.
4. Type of terrain.
5. Grass condition, wet or dry.

This mower has been designed to cut grass with heights from 10 to 20 cm. (4" to 8"). It is recommended to avoid cutting grass taller than 25 cm. (10"). For the best results, try cutting the grass at least once per week during growing season. Tall, dense grass should be cut at low speed, while thin medium grass can be cut at a faster ground speed. For cleaner cuts and efficient mowing, the blades must be kept sharp¹⁰.

Always operate PTO at 540 rpm. This is necessary to maintain proper blade speed and obtain a clean cut.

Under certain conditions, tractor tires may roll some grass down and prevent it from being cut at the same height as the surrounding area. If this occurs reduce the tractor

¹⁰ See Sharpening Blades in section 4.03 - Blade Maintenance.

ground speed but maintain a 540 rpm engine speed. The lower ground speed will permit the grass to at least partially rebound. Under some conditions grass will not rebound enough to be cut even, resulting in an uneven appearance. In general, lower cutting height gives a more even cut with less tendency to leave tire tracks. If cut is still not satisfactory, cut the area twice.

Mow extremely tall grass twice. On the first pass use a high cutting height. On the second pass position the mower at the desired height and when practical, mow at a right angle in travel to the first pass.

Plan your pattern to travel straight forward whenever possible.

It is better to cut grass more often, than too short. Short grass deteriorates rapidly in hot weather and invites weed growth during growing season.

If at any time the mower should jam resulting in belt slippage of 2 or more seconds, raise the mower and continue for 2-3 minutes. This will allow the pulleys to cool and prolong belt life.



DANGER: the mower blades can throw objects tens of meters (hundreds of feet) which could result in personal or property damage.

Pick up all rocks and other debris before mowing.

Enter new areas carefully. Cut grass higher at first, allowing mower to clear hidden objects.



CAUTION: for emergency reasons learn how to stop the tractor and mower quickly. On the Cyclone mowers always disengage the PTO, lock parking brake, stop engine and allow the mower blades to come to a complete stop before dismounting the tractor.

3.09 - Uneven Terrain



WARNING: be careful of roll-over when operating tractor and mower over uneven ground.

In extremely uneven terrain rear wheel weights, front tractor weights, and/or tire ballast should be used to improve stability.

When mowing over uneven terrain, observe the type of terrain and develop a safe mowing pattern. Whenever traction or stability is doubtful, first test drive over the terrain with the PTO disengaged.

Operate the mower up and down steep slopes, not across slopes, to prevent the tractor from tipping. Avoid sudden stops and starts, and slow down before changing directions on a slope.

Pass diagonally through sharp dips and avoid sharp drops to prevent hanging up the tractor and mower.

Slow down on sharp turns and slopes to prevent tipping or loss of control.

Avoid tipping the mower while cutting. Watch for holes, roots or other hidden objects.

Do not cut near the edge of a gully, ditch or stream bank.

3.10 - Removing Mower from the Tractor



CAUTION: disengage tractor PTO. Set parking brake. Stop engine and remove key from ignition. Disconnect mower driveline from tractor PTO shaft. Collapse driveline and secure it in place with the storage hook on the mower three point. Disconnect three point linkage and carefully drive tractor away from mower.

TABLE 1 - TORQUE SPECIFICATIONS

Diameter	Class 8.8		Class 10.9	
	N.m	lb.ft	N.m	lb.ft
M 8	25	18	35	26
M 10	50	37	70	52
M 12	90	66	125	92
M 14	140	103	200	148
M 16	215	155	305	225
M 18	295	217	420	309
M 20	420	302	590	438

When using locks, nuts, increasing torque values by 5%.

TABLE 2 - CYCLONE C70 - TECHNICAL FEATURES

Series C70, Rear Discharge, for tractors up to 70 HP, PTO 540 ¹ rpm, 3 point hitch cat. 1										
Model	Working width cm.	Overall width cm.	Weight kg	Rotor rpm/min	Blades tip speed m/sec.	# Blades	Cutting height mm.	# Belts & Type	# Wheels & Size	Driveline 1 ^{3/8} "
C70-230RD	230	235	480	1575	64.30	6	35 - 135	2 CX	4-310x100	ASAE 4 th cat.
C70-280RD	280	285	655	1405	68.70	6	35 - 135	2 CX	4-310x100	ASAE 4 th cat.

PTO 1000 rpm, available upon request.

4 - MAINTENANCE



DANGER: stop engine, lock parking brake and remove key before performing any service or maintenance.

Never rely on the tractor lift system. Install blocks or stands under the mower deck to prevent it from falling. Always use personal protection devices, such as glasses or gloves when performing maintenance.

Keep fingers out of slots to prevent injury.

4.01 - Maintenance Safety



1. Good maintenance is your responsibility.
2. Keep service area clean and dry. Be sure electrical outlets and tools are properly grounded. Use adequate light for the job at hand.
3. Make sure there is plenty of ventilation. Never operate the engine of the towing vehicle in a closed building. The exhaust fumes may cause asphyxiation.
4. Make no repair or adjustments with the tractor engine running. Before working on the machine, disengage the PTO, shut off the engine, set the brakes, and remove the ignition key.
5. Be certain all moving parts on attachment have come to a complete stop before attempting to perform maintenance.
6. Never work under equipment unless it is blocked securely.
7. Always use personal protection devices such as eye, hand and hearing protectors, when performing any service or maintenance.
8. Frequently check mower blades. They should be sharp, free of nicks and cracks and securely fastened.
9. Periodically tighten all bolts, nuts and screws and check that all cotter pins are properly installed to ensure unit is in a safe condition.
10. When completing a maintenance or service function, make sure all safety shields and devices are installed before placing unit in service.
11. Do not attempt to mount a tire unless you have the proper equipment and experience to do the job.
12. Inflating or servicing tires can be dangerous. Whenever possible, trained personnel should be called to service and/or mount tires.
13. After servicing, be sure all tools, parts and service equipment are removed.

14. Never replace hex bolts with less than grade five bolts unless otherwise specified, i.e. shear bolts¹¹.
15. When the machine is not hooked to the tractor, the driveline must be supported by the storage hook to the top link.
16. Where replacement parts are necessary for periodic maintenance and servicing, genuine replacement parts must be used to restore your equipment to original specifications. The company will not claim responsibility for use of unapproved parts and/or accessories and other damages as a result of their use.
17. Unauthorised modifications to the machine may impair the function and/or safety of the machine and reduce its life. If equipment has been altered in any way from original design, the manufacturer does not accept any liability for injury or warranty.

4.02 - Service

The accompanying illustrations show lubrication points. The chart gives the frequency of lubrication in hours, based on normal operating conditions. Severe or unusual conditions may require more frequent lubrication.

Use a good quality SAE multi-purpose type grease for all locations shown. Be sure to clean fittings thoroughly before using grease gun.

Use 90 wt. or 140 wt. gear oil in gearbox.

Hourly:

1. check the condition of mower blades for nicks or dull edges. Sharpen if necessary.
2. Replace bent or damaged blades¹². Also check blades for damage after hitting an obstruction.
3. Clean foreign material from mower deck and belt area.

Every 8 hours:

1. **lubricate driveline, lubricate caster wheels and wheel yokes:** apply two or three shots of grease to the driveline cross and bearings and the telescoping shafts; apply the same amount to the wheel arm grease fittings and the wheel grease fittings (**see fig. 6**). See the driveline manufacturer operator's manual for further information on the driveline.
2. **Gearbox oil level:** check gearbox oil level, it should be between $\frac{1}{2}$ and $\frac{2}{3}$ full. If needed add either SAE 90 wt. or SAE 140 wt. gear oil.

Every 25 hours: check hardware tightness; mower vibration can loosen bolts¹³. Check tightness of the hardware periodically, using this table as a guide.

¹¹ Refer to table 1 - Torque Specifications, for head identification marking.

¹² See section 4.03 - Blade Maintenance.

¹³ See table 1, page 20.

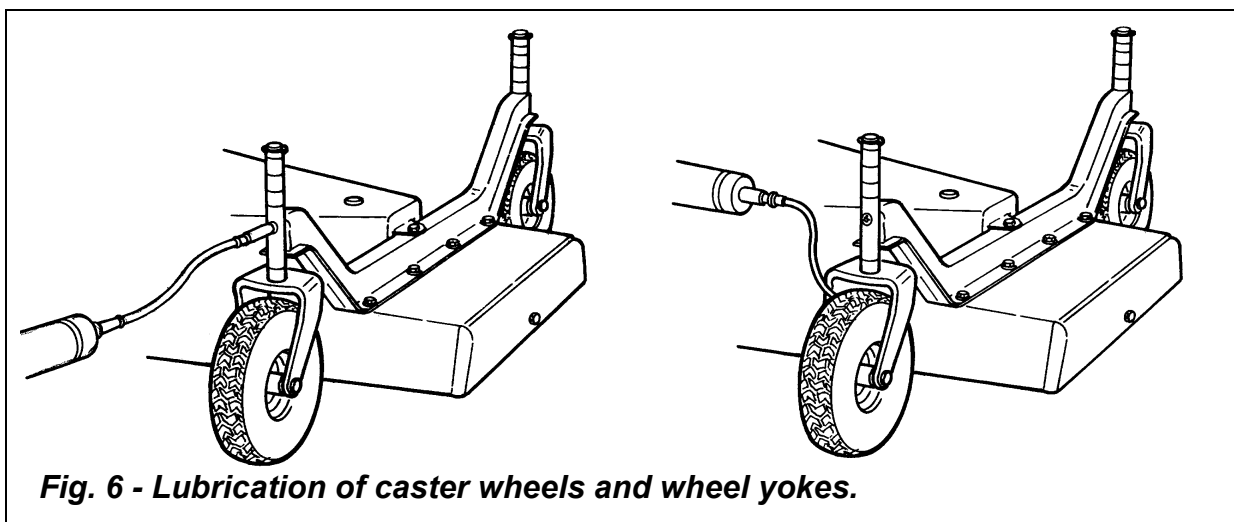
**Every 50 hours:**

1. lubricate the three spindles with two or three shots of multi-purpose grease (see **fig. 7**). The top grease fittings are easily accessible from the top of the deck by simply removing the plastic dust guards.
2. Check belt tension¹⁴.

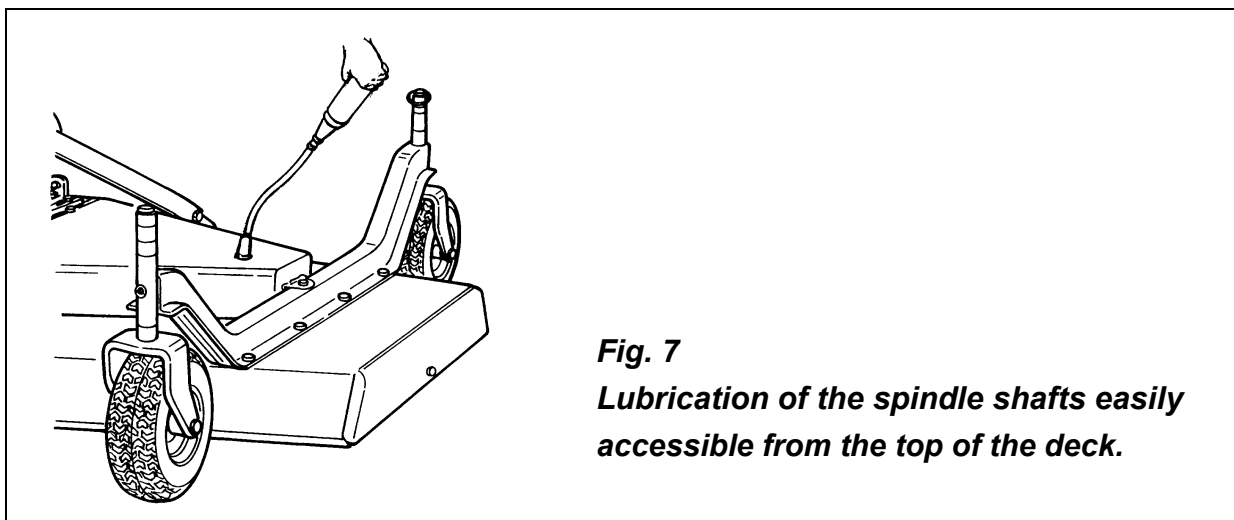

¹⁴ See section 4.04 - Belt Tension.

4.03 - Blade Maintenance



WARNING: avoid possible injury always wear proper eye and hand protection when servicing mower blades.

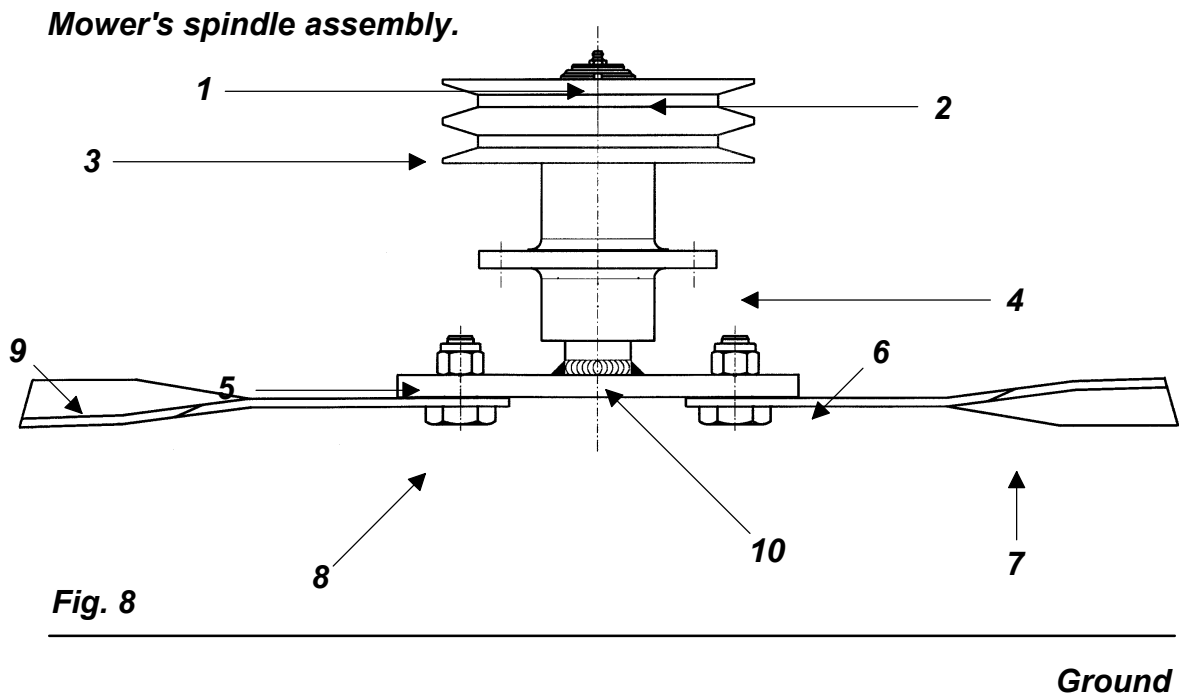

- | | |
|--------------------------|--------------------------------------|
| 1. grease fitting | 6. rotor |
| 2. nut | 7. blade |
| 3. pulley | 8. blade bolt |
| 4. rotor support | 9. lift wing |
| 5. nut | 10. shaft welded to the rotor |

In order for the mower to work properly, and to always obtain a precision cut with lower HP requirements thus keeping cost down, proper blade maintenance is important. Blades must be kept sharp, at their original length and corners maintained. A blade must be replaced if, due to wear or damage, its original shape has been distorted.

Removing or installing blades

If the mower blades need to be removed, do the following:

1. the blades rotate in a **clockwise** direction viewing the mower, when lifted, from the rear. The blades must be mounted with the cutting edge in the direction of rotation and the lift wing edge towards the bottom of the deck (**see fig. 8**).
2. Insert the blade bolt through the blade and then through the spindle, taking care to assemble it as described above (**see fig. 8**). Screw on the lock nut.
3. Tighten the lock nut to 145 N.m. (105 lb.ft.).
4. To remove the blades, reverse the procedure.



WARNING: do not substitute blades or any bolt for the blade retaining bolt. Company blades and blade retaining bolts are specially made for this application. Using non original parts can effect the quality of cut and may also cause damage to the mower.



DANGER: proper torque must be used when tightening the blade retaining bolt. If these safety precautions are not followed, the blade could come off during operation and be thrown tens of meters from the mower.

Sharpening Blades

Blade sharpening is extremely important in order to get the best cutting results. Sharp blades permit a high quality cut and also reduces HP thus lowering cost.

To sharpen blades, first remove them following the above instructions.

Place the blade in a vise and sharpen them by using a hand file or grinder. **Do not sharpen the blades to a sharp cutting edge.** The cutting edge should be between 0.5 to 0.6 mm. ($\frac{1}{64}$ " to $\frac{1}{32}$ ") to prevent excessive pitting and dulling of the blades. Sharpen each end of the blade equally for balance and always maintain corners. Always keep all six blades sharpened equally in order to maintain balance.



CAUTION: unbalanced or warped blades can cause damage to the mower and/or personal injury. Replace damaged blades before operating the mower. Sharpen each end of the mower blades equally or until the blades are balanced.

4.04 - Belt Tension

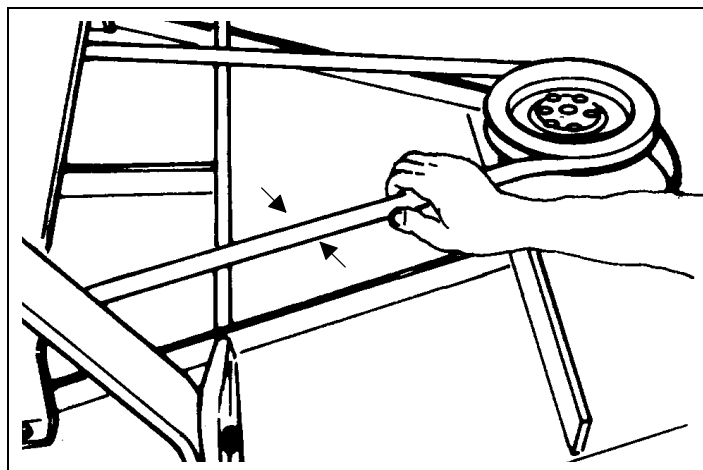

Fig. 9
The belt deflection should be between 8-10 mm. (5/16"-3/8").

Belt tension control

Check the belt tension (see fig. 9) by applying a force of 5-6 kg (12-15 lb.) pushing against the belt halfway between the pulleys. The belt deflection should be between 8-10 mm. (5/16"-3/8").

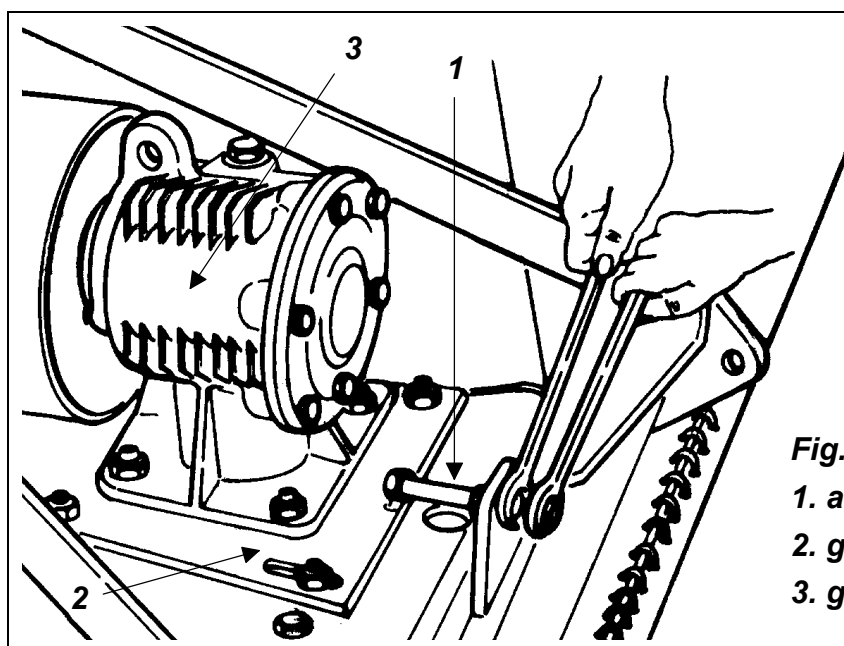

Fig. 10
1. adjustment bolt
2. gearbox support plate
3. gearbox

Belt tension adjustment

To adjust the tension of the C70, do the following (see fig. 10):

1. remove belt shields. Clean foreign material from the mower deck and belt area.
2. Loosen the four nuts holding the gearbox support plate to the central plate.
3. Loosen the two blocking nuts on the adjustment bolt.

4. Turn the adjustment bolt counter clockwise until the proper belt tension is reached. This will draw the gearbox support plate to the rear, thus tightening the belts.
5. Tighten the two blocking nuts on the adjustment bolt.
6. Re-tighten the four nuts holding the gearbox support to the central plate.
7. Reinstall the belt shields.

4.05 - Belt Replacement

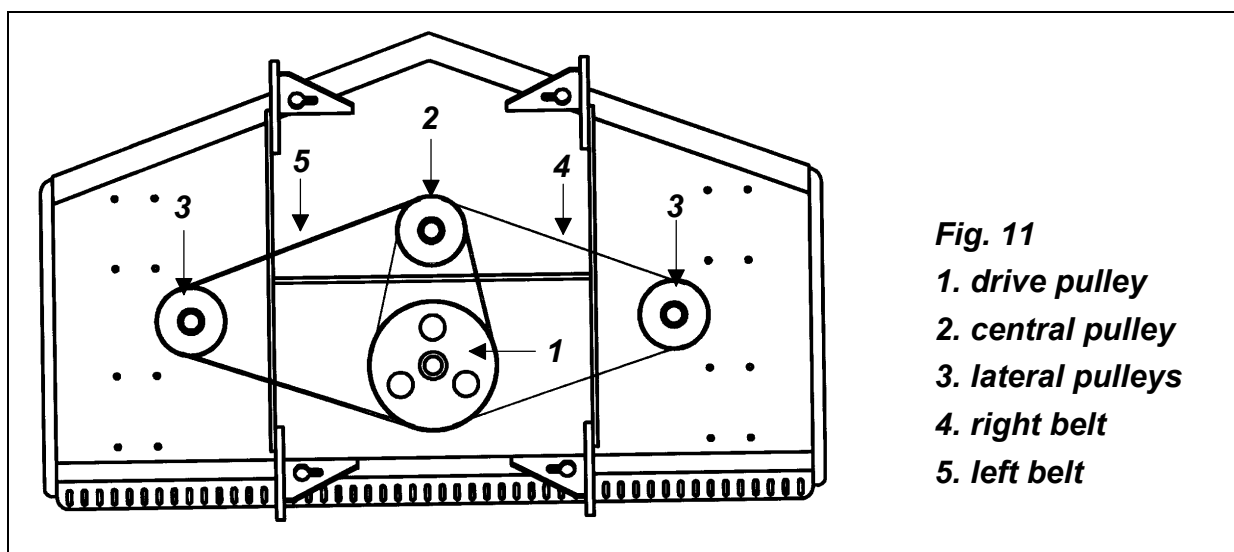

Fig. 11
1. drive pulley
2. central pulley
3. lateral pulleys
4. right belt
5. left belt

To replace belts do the following:

1. remove belt shields. Clean foreign material from the mower deck and belt area.
2. Loosen the four nuts holding the gearbox support plate to the central plate.
3. Loosen the two blocking nuts on the adjustment bolt.
4. Turn the adjustment bolt clockwise, pushing the gearbox support plate forward until all tension is released (**see fig. 10**).
5. Loosen rear nuts holding central plate (do not remove them).
6. Remove front nuts holding central plate.
7. Lift the front of the central plate and remove old belts.
8. Replace new belts (**see fig. 11**). Loop the first belt over the left spindle and around the lower groove of the centre spindle pulley and the lower groove of the gearbox drive pulley. The second belt connects the upper grooves of the centre spindle pulley and the gearbox drive pulley with the right spindle pulley.
9. Lower central plate.
10. Replace front nuts. Tighten front and rear nuts holding down central plate.
11. Turn the adjustment bolt counter clockwise until the belt proper tension is reached. This will draw the gearbox support plate to the rear, thus tightening the belts.
12. Tighten the two blocking nuts on the adjustment bolt.

13. Re-tighten the four nuts holding the gearbox support to the central plate and replace the belt shields.

4.06 - Driveline



DANGER: only use the original driveline supplied with this mower, and always with the safety shielding.

Carefully read and file away the driveline operator's manual supplied by the manufacturer. The following does not substitute the information found in the driveline manual.

Fig. 12

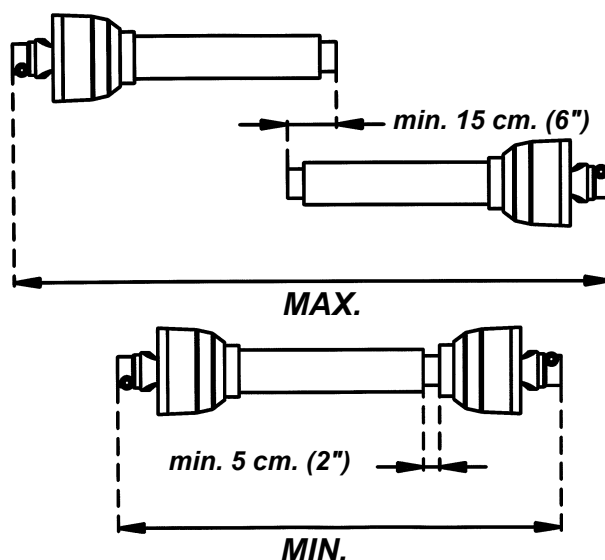

In the collapsed position the driveline should be approximately 5 cm. (2") from bottoming out to prevent possible damage to the tractor or implement. When the PTO is in the maximum extended position, the ideal minimum overlap of the two halves should be approximately 15 cm. (6") (see fig. 12).

If determined that the driveline is too long, follow these procedures to adjust the length:

1. separate the two driveline halves. Connect one half to the tractor PTO and the other half to the mower.
2. Raise and lower the mower with the 3 point hitch to find the position where the driveline is shortest. Hold the half shafts side by side and mark the desired length on the outer female tube guard leaving a 5 cm. (2") gap between the end of the guard tube and bell guard.
3. Cut off both guard tubes the same amount as marked in step 2.
4. Shorten both drive tubes the same amount as guard tubes.

5. De-burr and clean filings from drive tubes and apply grease to outside of inner telescoping tube.

Reassemble the driveline halves and connect to tractor and mower. Raise and lower mower again to be sure driveline does not bottom out in its shortest position and has a minimum overlap of 15 cm. (6") in the longest position.



CAUTION: always work with the driveline as straight as possible. This will prolong its life and that of its components. It is advised, not to work at an angle greater than 15 degrees.

When the mower is not hooked to the tractor, the driveline must be supported by the storage hook attached to the top link.

4.07 - Transport

Before raising the mower for transport, the tractor top link must be adjusted so when lifted, the rear of the machine is higher than the front (the mower's nose is tilted downward). To do this, shorten the tractor top link until the top hitch plate is locked forward and no longer able to pivot. This will keep the mower locked in position and minimize the shaking and bouncing during transport which can damage the hitch or frame. When raising the mower be sure the PTO driveline does not hit either the mower or the tractor. During transport the mower should not be lifted over 35-40 cm. (14"-16") from the ground.



CAUTION: make sure PTO is disengaged and blades have stopped turning before raising mower to full transport position. Do not tow tractor and mower behind other vehicles. Use a properly equipped trailer with heavy tie-downs for towing operations.

Before transporting:

1. disengage PTO.
2. Shorten tractor top link until top hitch plate is locked.
3. Raise machine and lock rockshaft control lever.
4. Always select a safe ground speed that is appropriate for the terrain.
5. Beware of traffic on public roads. Install a SMV (Slow Moving Vehicle) sign when travelling on roads or streets.
6. Reduce ground speed when turning and take care that the mower does not strike obstacles such as trees, fences or buildings.

5 - REPAIR PROCEDURES



CAUTION: all repair procedures must be done by authorised dealerships. It is not recommended that untrained individuals perform any repair work. The following operations are detailed for qualified personnel only.

5.01 - Gearbox

To remove the gearbox do the following (see fig. 10):

1. remove the belts¹⁵.
2. Remove the nuts holding the central plate to the frame.
3. Remove the nut holding the pulley to the gearbox pinion shaft. Remove the pulley.
4. Unbolt the nuts holding the gearbox support plate to the central plate. Remove gearbox and gearbox support plate.
5. Unbolt the nuts holding the gearbox from the gearbox support plate. Remove the gearbox.

If it is necessary to replace any part on the inside of the gearbox, it is important to replace oil seals or gaskets to ensure a tight fit when reassembling.

To replace the gearbox, follow the above instructions in reverse order.

5.02 - Blade Spindle

To remove the blade spindle do the following:

1. remove the belts¹⁶.
2. Remove the safety nut holding the pulley to the spindle shaft (see fig. 10). Remove the pulley.
3. Remove the bolts holding the spindle assembly to the deck and remove the assembly.
4. Press out the spindle shaft.
5. If necessary remove and replace the bearings from the rotor using presses or extractors. Take care not to damage the oil seals. Replace them if necessary.

¹⁵ See section 4.05 - Belt Replacement.

¹⁶ See section 4.05 - Belt Replacement.

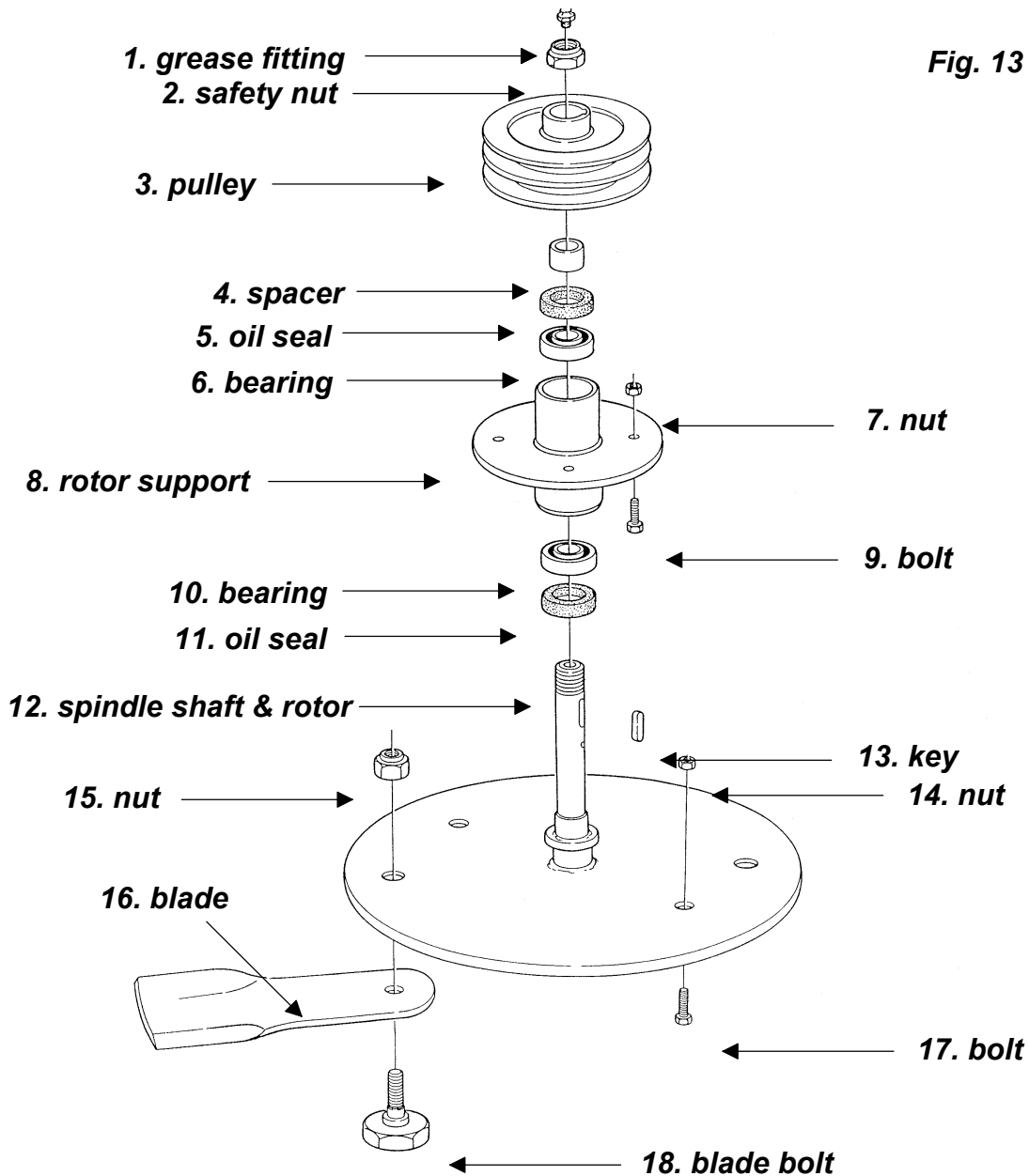

To reassemble the blade spindle, do the following:

1. clean the spindle housing support. Remove shavings and/or burrs.
2. Rub oil on the mounting surfaces. Press the bearing races into the rotor support (**see fig. 13**).
3. Apply a layer of grease to the inner ring of the bearing. Pack the bearings with grease.
4. Carefully lubricate the oil seal and assemble it on the spindle shaft with the lip turned down toward the blade mounting plate.
5. Place the bearing over the spindle shaft.

6. Assemble the rotor support over the spindle shaft, taking care not to damage the oil seal.
7. Place the upper bearing, the adjustment spacer and the oil seal (assemble it with the lip towards the bearing) over the spindle shaft. Be sure all parts are lubricated prior to assembly. Take care not to damage the seal.
8. Bolt the spindle assembly to the deck.
9. Place the key in the keyway and mount the pulley onto the shaft.
10. Tighten the locking nut while turning the spindle. Tighten the spindle until resistance is felt. Tighten until there is no up and down play in the pulley.
11. Back off $\frac{1}{12}$ of a turn so the spindle turns without resistance.
12. Be sure the grease fitting is in the shaft (**see fig. 13**).
13. Replace the belts and the belt covers.
14. Grease the spindle assembly.

5.03 - Suggested Spare Parts

It is suggested that the following spare parts be kept on hand for the C70 at all times to prevent a minor problem from delaying work.

Description	Quantity
Blades	6
Blade bolts	6
Belts	1 set

5.04 - Storage

After seasonal use it is important to perform the following for prolonged storage:

1. wash the mower carefully.
2. Inspect the mower and replace worn or damaged parts.
3. Tighten all hardware. Grease all areas indicated under Maintenance.
4. Loosen the belts if the mower is to be stored for an extended length of time.
5. Cover the mower from the elements in order to have it in perfect condition for the start of the next season.

6 - TROUBLESHOOTING



WARNING: be sure the tractor's engine is off, parking brake is locked, and key is removed before making any adjustments.

PROBLEM	POSSIBLE CAUSE	SOLUTION
Uneven Cutting.	Cup washer not between blade and bolt. Ground speed too fast. Blades need sharpening. Caster wheels uneven.	<i>Check washer location at all 3 spindles. Shift to lower gear. Sharpen blades. Adjust wheel position.</i>
Blades turning but not cutting.	Direction of blades is wrong.	<i>Blade should turn clockwise when you face deck bottom. See installing blade section.</i>
Belt slippage.	Lack of tension. Object clogging mower. Debris in pulleys.	<i>Tighten Belt. Remove object. Clean pulleys.</i>
Mower vibrates.	Object wrapped around blade. Belt damaged.	<i>Remove object. Replace belt.</i>
Belt squeal.	Belt slipping.	<i>Tighten belt.</i>
Grass build up at exit.	Wet grass. Grass too high. Tractor rpm too slow.	<i>Allow grass to dry. Raise mower, shift to lower gear, make two passes over grass. Mow grass high 1st pass, 2nd pass cut to desired height. Increase tractor rpm, check engine and PTO speeds.</i>
Belts are tight when installing.	Wrong belt size. Belts installed incorrectly.	<i>Check belt size. See Replacing Belts section.</i>
Streaking conditions in swath.	Too wet to mow. Blades cannot cut grass pressed down by wheels. Dull blades. Blades worn down, preventing overlap.	<i>Allow grass to dry. Maintain engine speed and shift to lower gear. Sharpen blade. See sharpening blades section. Change blades.</i>
Cut grass windrows.	Ground speed too low. Tractor rpm too slow.	<i>Increase ground speed. Increase tractor rpm, check engine and PTO speeds.</i>

7 - PRE-DELIVERY CHECKLIST

To the dealer: inspect the machine thoroughly after assembly to assure it is functioning properly before delivering it to the customer. The following checklist is a reminder of points to cover. Check off each item as it is found satisfactory or after proper adjustment is made.

- Gearbox oil level.
- Guards and shields properly fastened.
- Lubrication of grease fittings.
- All hardware properly tightened.
- All decals properly located and readable (**see fig. 2**).
- Blades properly installed, blade bolts & nuts tightened.
- Overall condition (touch up scratches, clean and polish).
- Test run, check for excessive vibration or overheating of bearings.
- Operator's Manual.

Review the operator's manual with the customer. Explain the following:

- Warranty.
- Safe operation and service.
- Correct machine installation and operation.
- Daily and periodic lubrication, maintenance and inspections.
- Troubleshooting.
- Operational procedures and storage.
- Parts and service.
- Remove and fill out the Delivery and Warranty Registration form.
- Give customer the operator's manual and encourage the customer to read the manual carefully.

IMPORTANT: warranty is not valid unless Delivery and Warranty Registration Form in operator's manual is completed in detail and mailed to the Company.

Model Number: _____ Serial Number: _____

Delivery Date: _____ Dealer's Signature: _____

8 - WARRANTY

The Company warrants its machine from defects in material and workmanship. The machines are warranted from the invoice date for the following periods.

1. **24 months** for private use.
2. **12 months** for commercial, contractual and public use.
3. **30 days** for loan or rental.

This warranty is valid only if the Warranty Registration Form is properly completed and sent to the Company within 14 days of delivery along with copy of the invoice.

This warranty is valid only if the machine is paid for in full.

The warranty coverage shall not be transferable from the first owner to any subsequent owner.

This document is the only warranty for this machine, any other promises, express or implied other than those set forth herein are not applicable.

The customer can not request any special provisions or changes to this warranty covering additional responsibilities or liability from the Company.

The Company determines whether the warranty covers the substitution or the repairing of the machine or parts.

The customer is responsible, in all cases, for expenses of lubricants, transportation, any custom duties and applicable taxes.

The substitution or the repair of parts under warranty do not extend the length of said warranty.

This limited warranty does not apply to and excludes drivelines and driveline related safety devices (shear pin yokes, shear pins, slip clutches, clutch discs), tires, belts, blades and other wear items.

At no time will the responsibility of the Company surpass the original purchase price of the machine. The purchaser agrees, not to have any rights to any compensation from the Company, including but not limited to, any eventual damages or accidents, loss of profit, loss of sales, injuries or damages of any kind or nature, or other accidents or losses which could result.

If during the period covered by this warranty, the machine fails to perform due to material or workmanship defects, the purchaser is to immediately make the Company aware of this defect. It is the Company's right to determine if the machine is to have parts replaced, repaired or the machine returned.

The Company will not accept any returned items without prior express written authorisation.

This warranty does not cover cost of labour for the replacement of parts.

Misuse or use of this machine other than ways outlined in the operator's manual or literature invalidates this warranty.

All obligations of the Company under this limited warranty shall be terminated if original parts of this machine have been modified or altered in any way, the machine has been repaired by unauthorised dealers, or when unauthorised spare parts have been used.

The Company reserves the right to modify or update machines without the obligation of modifying or updating previously sold machines.

Venue: any judgements will be decided by the Verona Court.

<p>EC Declaration of Conformity according to Directive 2006/42/EC</p>
<p>We</p> <p>ROTOMECC spa Via Molino di Sopra, 56 37054 Nogara (Verona), Italy</p> <p>declare under our sole responsibility, that the product</p> <p style="text-align: center;">Grooming Mower Cyclone 'C70'</p> <p>to which this declaration relates corresponds to the relevant basic safety and health requirements of the Directive 2006/42/EC. For the relevant implementation of the safety and health requirements mentioned in the Directives, the following standards were consulted: EN 836:1997, EN 836:1997/A1:1997, EN 836:1997/A2:2001, EN 836:1997/A3:2004. National and International Requirements: ISO 11684:1995.</p> <p>Pio G. Figna Chief Executive Officer</p> <p style="text-align: right;">Nogara, _____</p>

<p>Determination of vacuum sound power levels under static conditions. Acoustic pressure: Leq dB (A) = 95,4. Acoustic power LwA (dBA) = 111.</p>
--

WARRANTY REGISTRATION

ROTOMECC spa
Via Molino di Sopra, 56
37054 Nogara (Verona) - Italy

Tel.: 0442.510400 - Fax: 0442.510038

Dealer	Acct. #	Retail Customer
Street	Country	Street
Town	State Zip	Town State Zip
Date of delivery	Invoice #	Phone
Model #	Serial #	Date
<p>Pre-Delivery Check List:</p> <ul style="list-style-type: none"> <input type="checkbox"/> Oil in gearbox. <input type="checkbox"/> Greased fittings. <input type="checkbox"/> Safety guards in place. <input type="checkbox"/> All hardware tight. <input type="checkbox"/> Blades bolts torqued correctly. <input type="checkbox"/> Attached unit to tractor. Yes/No. <input type="checkbox"/> Field adjusted. Yes/No. <input type="checkbox"/> Test run. Dry/Infield. <input type="checkbox"/> Instruction Sticker. <input type="checkbox"/> Operator's manual. <p>The machine described above, had been prepared for delivery according to the Pre-Delivery Check List and the Customer has been instructed in its care and operation and the condition of warranty.</p>		<p>Tractor make: _____ Model: _____; HP _____ Type of operation: maintaining lawns, sport fields, golf courses, turf farms, parks, schools, airports, hospitals, municipalities, other: _____</p> <p>Approximate number of acres machine will be used on annually: _____</p> <p>I hereby acknowledge that: I have received and accepted delivery of the machine described. The equipment was checked thoroughly for loose or missing parts and has been adjusted in accordance with the pre-delivery check-list. I have read and understood the nature and extent of the warranty and understand clearly that there were and are no other representations of warranties either express or implied, made by anyone. I have been advised on proper operation, maintenance and lubrication procedure of this equipment. I have been instructed on and do understand the application, limitation and capacities this equipment was designed and recommended for, all as described in the operator's manual and literature published by Rotomecc.</p>
Inspected by: _____		Date: _____
Date: _____		Customer's Signature: _____
Dealer's Signature: _____		

This Delivery and Warranty Registration Form must be filled out and returned, by registered letter, within 14 days to the Company.

Sender:

Fold here

*Place stamp
here*

ROTOMECC spa
Via Molino di Sopra, 56
37054 Nogara (VR)
ITALY

Cut along this line

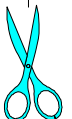

Use only original spare parts

All rights reserved. It is unlawful to copy, reprint or use any of the information or details in this manual without the expressed written permission of ROTOMEC spa, Nogara, (Verona) Italy. Technical information provided in this manual is approximate, the Company reserves the right to modify or improve the models shown for technical or commercial purposes. Pictures in this manual do not necessarily show the machine as delivered.

ROTOMECC spa

Via Molino di Sopra, 56

37054 Nogara (VR) - ITALY

Tel: +39.0442.510400 Fax: +39.0442.510038

www.rotomecc.com

